

INTERSTATE MILEPOST PLAQUE

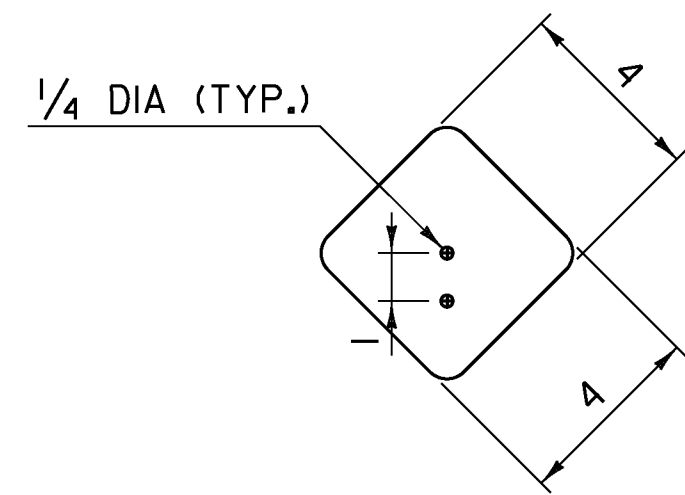

TYPE I DELINEATOR

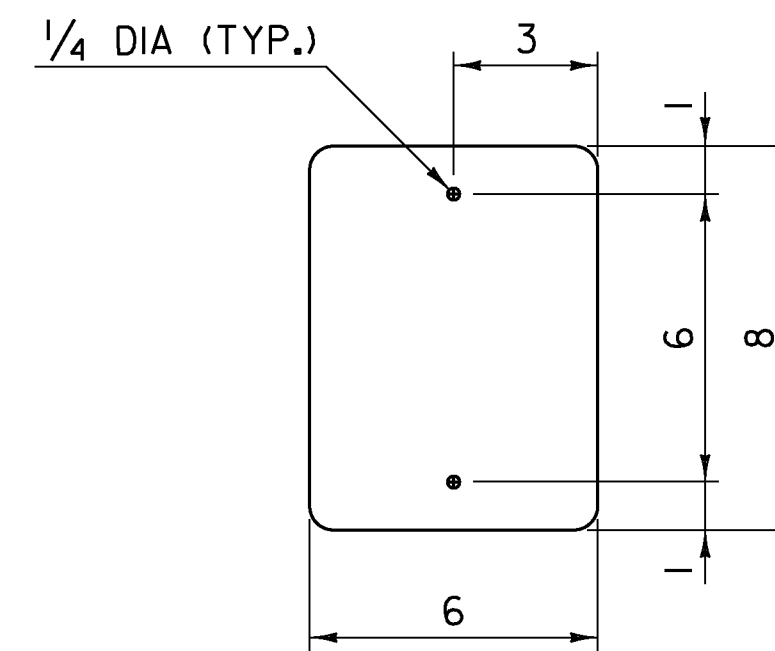

TYPE II DELINEATOR

GENERAL NOTES:

1. THE FIRST LINE OF TEXT ON INTERSTATE MILEPOST PLAQUES INDICATES THE WHOLE NUMBER MILEAGE FROM THE BEGINNING OF A ROUTE. MILEAGE IS ALWAYS MEASURED TRAVELING FROM THE SOUTH TO NORTH OR FROM THE WEST TO EAST. THE ROUTE DIRECTION IS ESTABLISHED USING THE VERMONT AGENCY OF TRANSPORTATION (VAOT) ROUTE LOGS.
2. THE SECOND LINE OF TEXT ON INTERSTATE MILEPOST PLAQUES INDICATES THE ADDITIONAL MILEAGE, IN HUNDREDTHS, FROM THE BEGINNING OF A ROUTE. MILEAGE IS ALWAYS MEASURED TRAVELING FROM THE SOUTH TO NORTH OR FROM THE WEST TO EAST. THE ROUTE DIRECTION IS ESTABLISHED USING THE VAOT ROUTE LOGS.
3. THE INTERSTATE MILEPOST PLAQUE SHALL BE GREEN RETROREFLECTIVE LEGEND ON A WHITE RETROREFLECTIVE BACKGROUND AND SHALL HAVE RETROREFLECTIVE SHEETING EQUAL TO OR EXCEEDING "AMERICAN ASSOCIATION OF STATE HIGHWAY AND TRANSPORTATION OFFICIALS" (AASHTO) M 268 ["AMERICAN SOCIETY FOR TESTING AND MATERIALS" (ASTM) D 4956] TYPE III.
4. ALL LINES OF TEXT SHALL BE CENTERED HORIZONTALLY AND SHALL BE AS IDENTIFIED IN THE PLANS.
5. THE INTERSTATE MILEPOST PLAQUE AND DELINEATOR BASE MATERIAL SHALL BE 0.063 INCH FLAT SHEET ALUMINUM.
6. CORNERS SHALL BE ROUNDED TO A 1/2 INCH RADIUS.
7. A TYPE III DELINEATOR CONSISTS OF A TYPE I DELINEATOR FACING THE NORMAL DIRECTION OF TRAVEL AND A SINGLE RED TYPE I DELINEATOR FACING THE OPPOSITE DIRECTION. THE WHITE DELINEATOR AND RED DELINEATOR COMBINATION IS PLACED ON THE DRIVER'S RIGHT AND THE AMBER DELINEATOR AND RED DELINEATOR COMBINATION ON THE DRIVER'S LEFT.
8. DELINEATORS SHALL HAVE WHITE, GREEN, OR BLUE RETROREFLECTIVE SHEETING EQUAL TO OR EXCEEDING AASHTO M 268 ASTM D 4956 TYPE III, OR RED OR YELLOW RETROREFLECTIVE SHEETING EQUAL TO OR EXCEEDING AASHTO M 268 ASTM D 4956 TYPE VII, VIII, OR IX.
9. A SINGLE 14 GAGE, 1.75 INCH SQUARE STEEL POST AND 12 GAGE, TWO INCH SQUARE ANCHOR SHALL BE USED FOR INSTALLATION. THE ANCHOR SHALL BE A MINIMUM OF 30 INCHES IN LENGTH.
10. THE TOP OF POST SHALL BE ONE INCH ABOVE THE UPPER HOLE FOR ALL TYPE I DELINEATORS.
11. THE TOP OF POST SHALL BE FLUSH WITH THE TOP OF ALL TYPE II DELINEATORS.
12. ALL DIMENSIONS SHOWN IN INCHES.

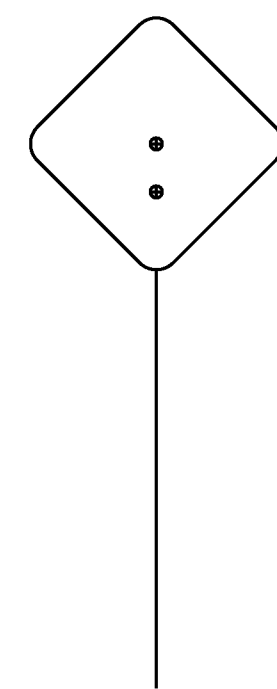

TYPE I

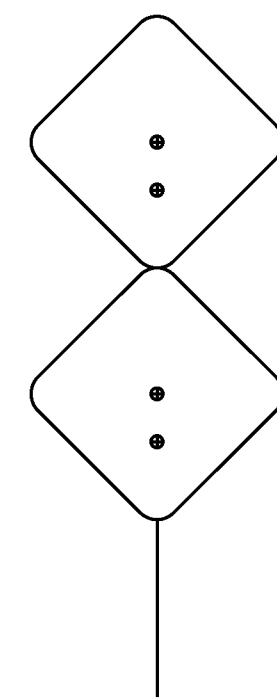

TYPE I - U-TURNS

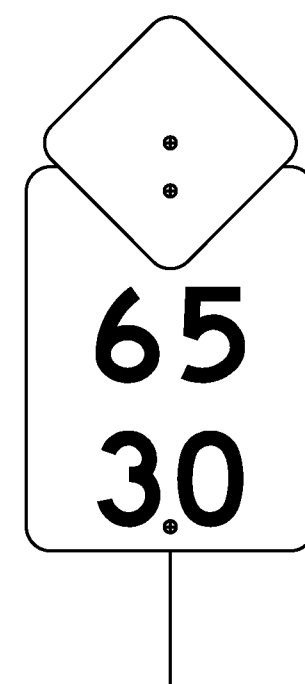

WHITE TYPE I WITH MILEPOST PLAQUE

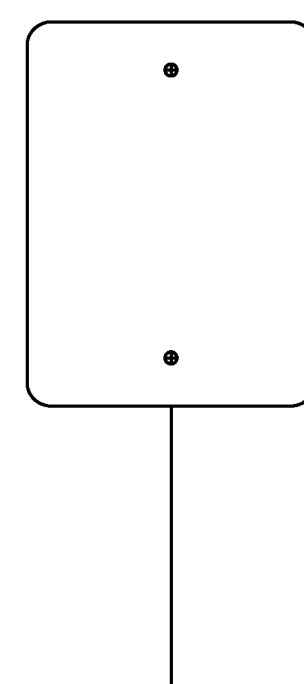

TYPE II

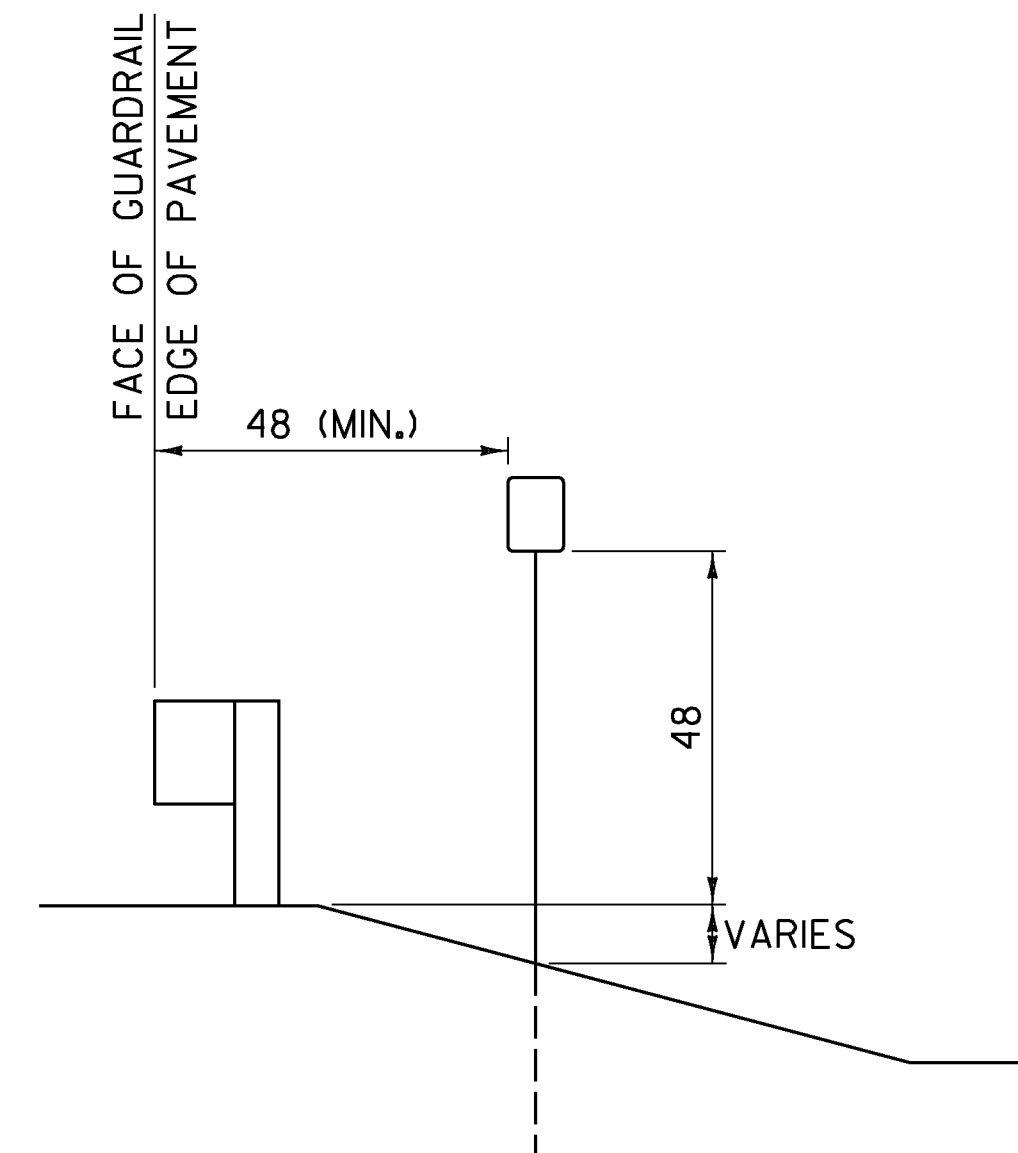

INSTALLATION DETAIL*

* INSTALLATION DETAIL APPLICABLE TO ALL DELINEATOR ASSEMBLIES

OTHER STDS. REQUIRED: T-45

REVISIONS AND CORRECTIONS
JAN. 2, 2013 - ORIGINAL APPROVAL DATE

APPROVED
[Signature]
HIGHWAY SAFETY & DESIGN ENGINEER
[Signature]
DIRECTOR OF PROGRAM DEVELOPMENT
[Signature]
MARK D. RICHTER
FEDERAL HIGHWAY ADMINISTRATION

DELINEATORS AND MILEPOSTS



**STANDARD
T-40**