

F5 Threaded Insert

The Dayton Superior F5 Threaded Inserts have National Course (NC) threads and are recommended for use under permanent loading conditions. This insert has been approved by the Board of Standards and Appeals for use in New York City under Calendar No. 447-60SM.

The F5 insert is cast from ductile iron that meets ASTM A-395, Grade 60-40-18.

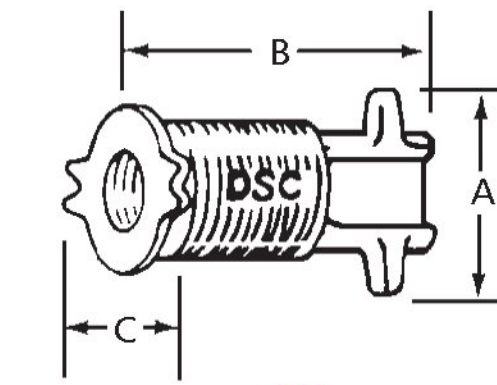

F5 Threaded Insert

To Order:
Specify: (1) quantity, (2) name, (3) bolt diameter.

Example:
200, F5 Threaded Inserts, 3/4" bolt diameter.

F5 Threaded Insert Selection Chart					
Bolt Diameter and Threads per Inch	Tension Safe Working Load	Bolt Engagement	A	B	C
1/2" - 13	1,500 lbs.	15/16"	1-5/8"	2-1/2"	1-5/8"
5/8" - 11	2,000 lbs.	3/4"	1-5/8"	3"	1-5/8"
3/4" - 10	2,500 lbs.	7/8"	1-13/16"	3"	1-7/8"
7/8" - 9	3,000 lbs.	1-5/16"	2-1/2"	3-3/8"	2-5/8"
1" - 8	3,000 lbs.	1-5/16"	2-1/2"	3-3/8"	2-5/8"

Safe Working Load provides a factor of safety of approximately 3 to 1 when the insert is properly embedded in 3,000 psi normal weight concrete.

F42 Loop Ferrule Insert

The Dayton Superior F42 Loop Ferrule Insert is fabricated by welding a looped strut to a closed-end ferrule. F42 insert is available in the sizes shown in the chart below and is well suited for structural connections and the suspension of equipment, piping, etc.

Minimum spacing between inserts is twice the minimum corner distance.

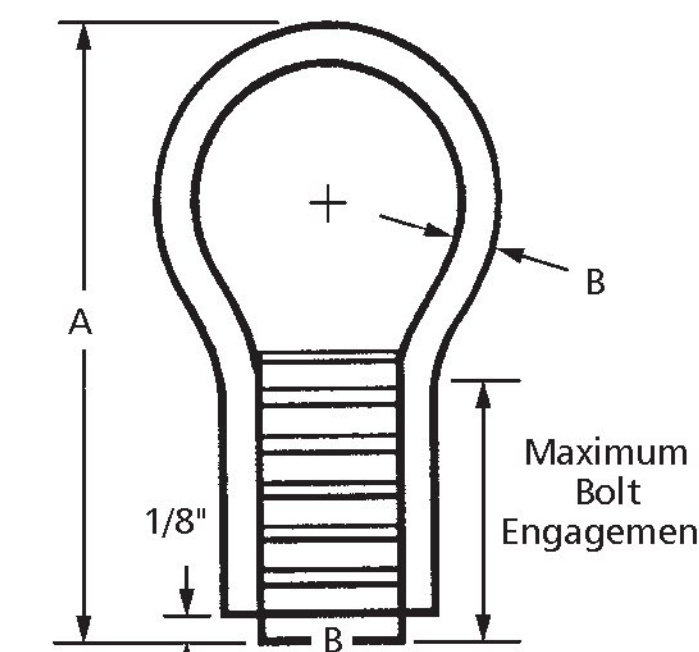

F42 Loop Ferrule Insert

To Order:
Specify: (1) quantity, (2) name, (3) bolt diameter.

Example:
200, F42 Loop Ferrule Inserts, 3/4" bolt diameter.

F42 Loop Ferrule Insert Selection Chart							
Bolt Diameter and Threads per Inch	Minimum Edge Distance	Minimum Corner Distance	Safe Working Load Tension	Safe Working Load Shear	Maximum Bolt Engagement	A	B
1/4" - 20 NC	5"	5"	650 lbs.	650 lbs.	3/4"	2-3/4"	0.243"
3/8" - 16 NC	5"	5"	2,000 lbs.	1,260 lbs.	3/4"	2-3/4"	0.243"
	10"	15"	2,000 lbs.	2,000 lbs.			
1/2" - 13 NC	5"	5"	2,000 lbs.	1,280 lbs.	1"	2-3/4"	0.243"
	7"	10"	2,000 lbs.	2,000 lbs.			
5/8" - 11 NC	5"	7"	2,200 lbs.	1,990 lbs.	1-1/8"	3-1/2"	0.258"
	8"	8"	2,200 lbs.	2,200 lbs.			
3/4" - 10 NC	5"	7"	2,200 lbs.	1,990 lbs.	1-1/8"	3-1/2"	0.258"
	8"	8"	2,200 lbs.	2,200 lbs.			
7/8" - 9 NC	8"	8"	5,300 lbs.	4,060 lbs.	1-1/8"	6"	0.375"
	10"	15"	5,300 lbs.	5,300 lbs.			
1" - 8 NC	8"	8"	5,300 lbs.	4,060 lbs.	1-1/8"	6"	0.375"
	10"	15"	5,300 lbs.	5,300 lbs.			

Safe Working Load provides a factor of safety of approximately 3 to 1 in 3,000 psi normal weight concrete. Safe Working Loads are based on 1/2" setback from face of concrete.

Structural Connectors

Vermont Agency of Transportation
RECEIVED
 CK'D BY CLB OK'D BY CWC
 February 16, 2018
 RESUBMIT No Approved
 BY C. CARLSON DATE 02/16/18