

PLAN VIEW

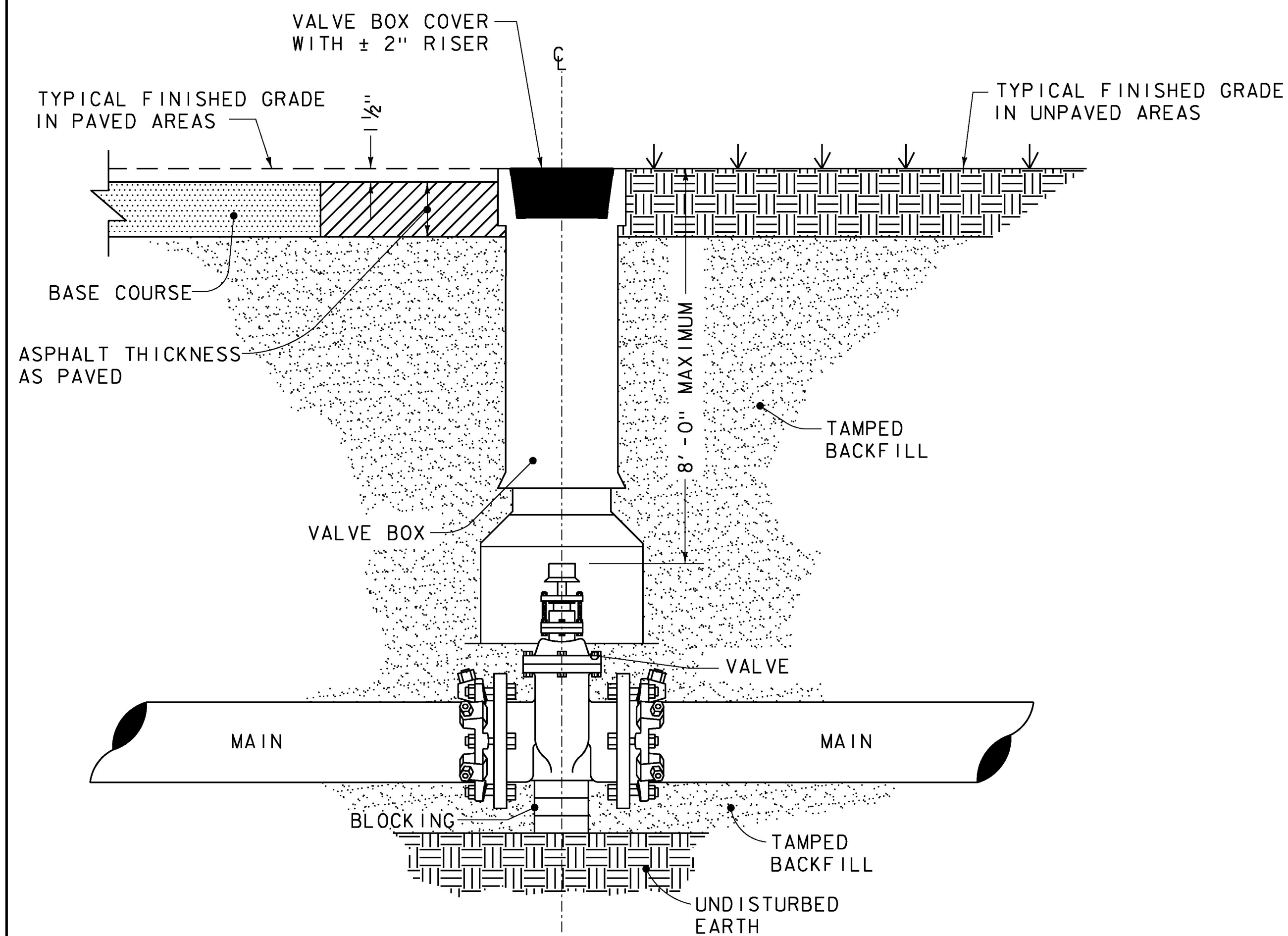

SECTION VIEW

STANDARD VALVE BOX INSTALLATION

- NOTES:**
1. ONLY MANUFACTURED VALVE BOX EXTENSIONS SHALL BE ALLOWED.
 2. VALVE OPERATING NUT MUST BE EXTENDED SO THAT THE DEPTH IS NO GREATER THAN 8 FEET FROM THE SURFACE USING A MANUFACTURER APPROVED EXTENSION KIT.

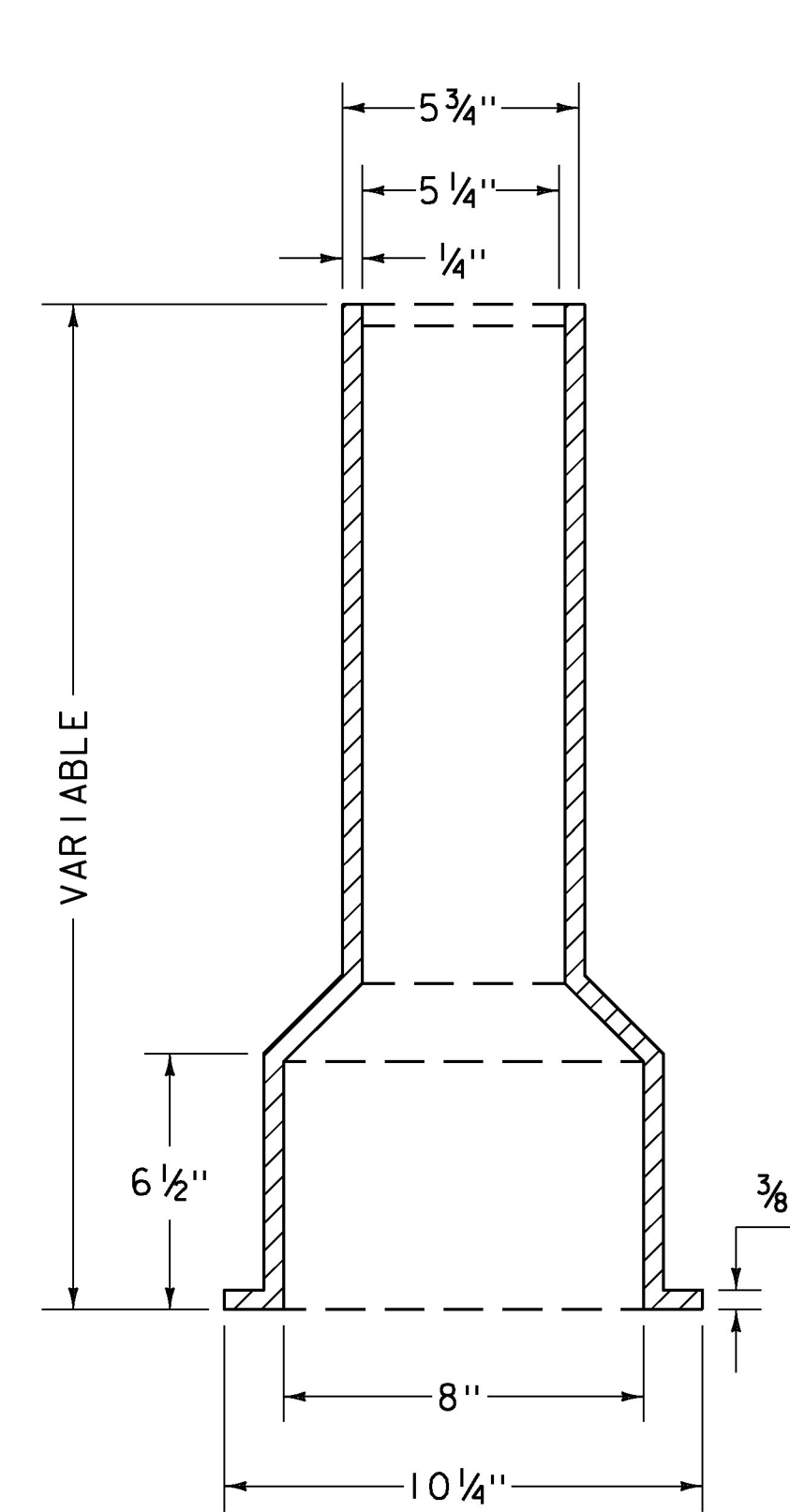

BOTTOM SECTION

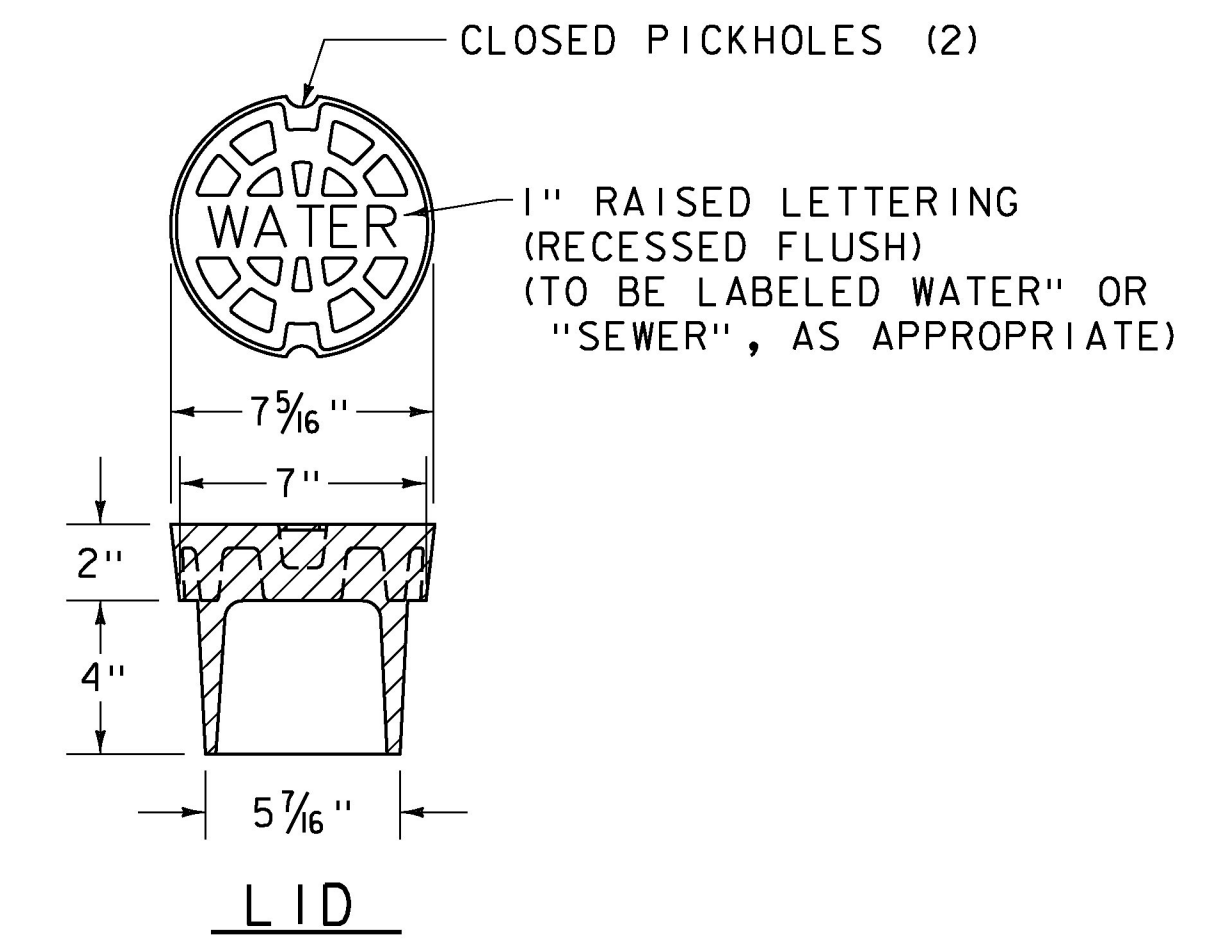

LID

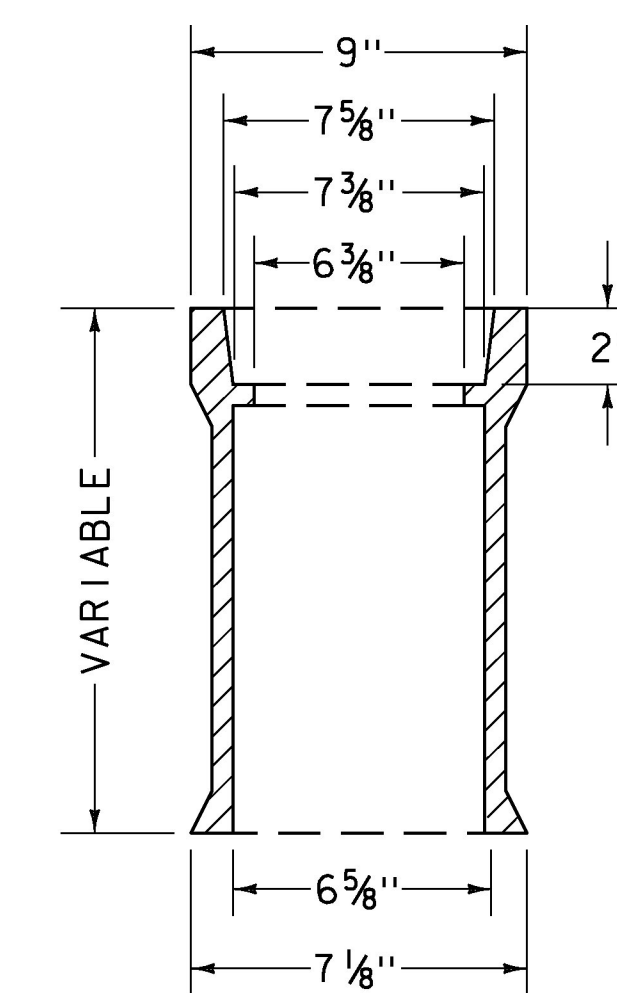

SLIDING TOP SECTION

BOX SHALL BE CENTERED OVER VALVE

ALL PARTS SHALL BE OF THE SAME MATERIAL AND SUPPLIED BY THE SAME MANUFACTURER

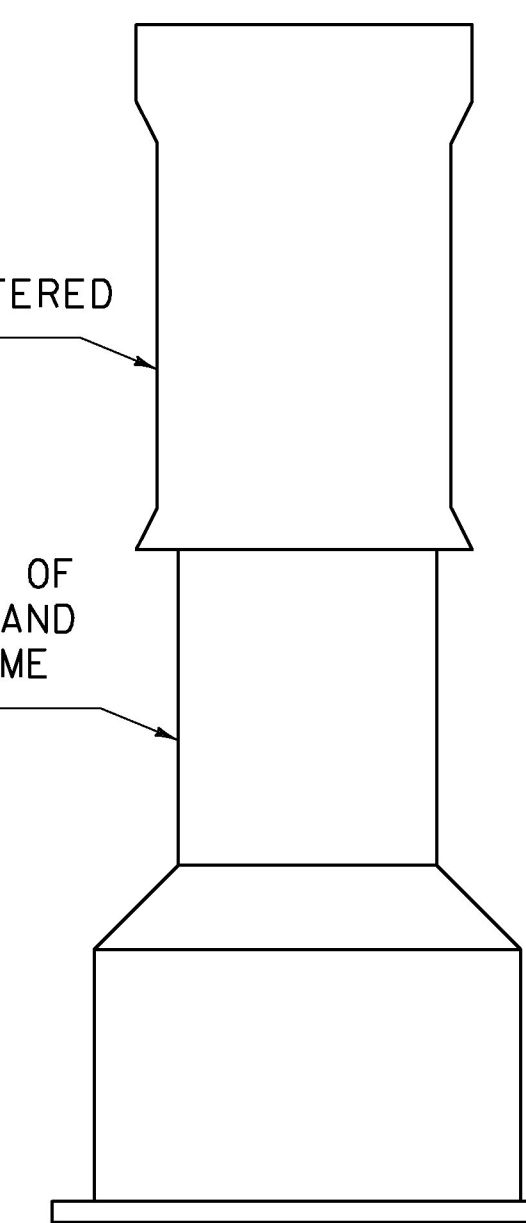

COMPLETE BOX

STANDARD VALVE BOX INSTALLATION

NOTES:

1. VALVE BOX COVER SHALL WEIGH A MINIMUM 26 LBS.
2. ENTIRE VALVE BOX ASSEMBLY & COVER SHALL BE CAST FROM CLASS 35 GRAY IRON.
3. ASSEMBLY SHALL BE DOMESTICALLY MADE AND MANUFACTURED IN THE U. S. A.

PROJECT NAME:	SOUTH BURLINGTON-WILLISTON
PROJECT NUMBER:	NH 2944(I)
FILE NAME:	zlid340detalls.dgn
PROJECT LEADER:	G. EDWARDS
DESIGNED BY:	J. LITTLE
VALVE BOX DETAIL SHEET	
PLOT DATE:	2/15/2017
DRAWN BY:	D. BARNES
CHECKED BY:	J. LITTLE
SHEET	24 OF 249

