

TEMPORARY 4 INCH WHITE LINE, PAINT  
 DURABLE 4 INCH WHITE LINE (OPTION BID ITEM)  
 W232+50 TO W242+68 SOLID LT  
 W232+50 TO W244+50 SOLID RT  
 W242+68 TO W242+95 SOLID LT (TH 30)  
 W243+20 TO W243+48 SOLID LT (TH 30)  
 W243+48 TO W244+50 SOLID LT

TEMPORARY 4 INCH YELLOW LINE, PAINT  
 DURABLE 4 INCH YELLOW LINE (OPTION BID ITEM)  
 W232+50 TO W233+50 SOLID LT, DASHED RT  
 W233+50 TO W236+00 DASHED CL  
 W236+00 TO W242+35 DASHED LT, SOLID RT  
 W242+35 TO W242+88 SOLID LT & RT  
 W243+08 DOUBLE SOLID LT (TH 30)  
 W243+28 TO W243+75 SOLID LT & RT  
 W243+75 TO W244+50 SOLID LT, DASHED RT

TEMPORARY 24 INCH STOP BAR, PAINT  
 DURABLE 24 INCH STOP BAR (OPTION BID ITEM)  
 W242+87 TO W243+07 SOLID LT (TH 30)  
 TEMPORARY LETTER OR SYMBOL, PAINT  
 DURABLE LETTER OR SYMBOL (OPTION BID ITEM)  
 W243+02 LT - STOP (TH 30)

STEEL BEAM GUARDRAIL, GALVANIZED  
 W232+50 TO W235+53.5 LT  
 W232+50 TO W234+43 RT  
 ANCHOR FOR STEEL BEAM RAIL  
 W235+53.5 LT  
 W234+43 RT

DELINEATOR WITH STEEL POST  
 W235+53.5 LT  
 W234+43 RT  
 REMOVING SIGNS  
 AS SHOWN - 4

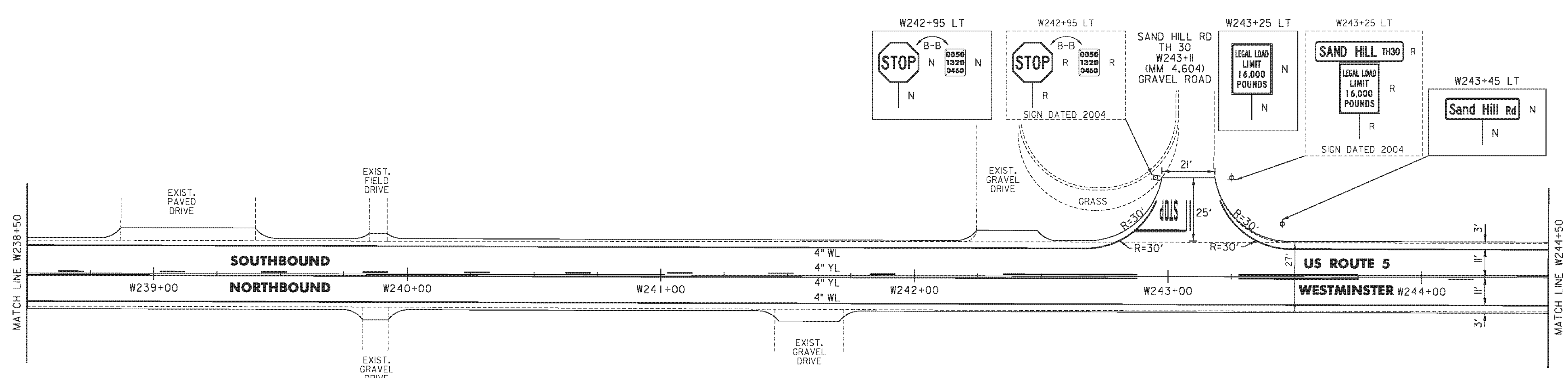
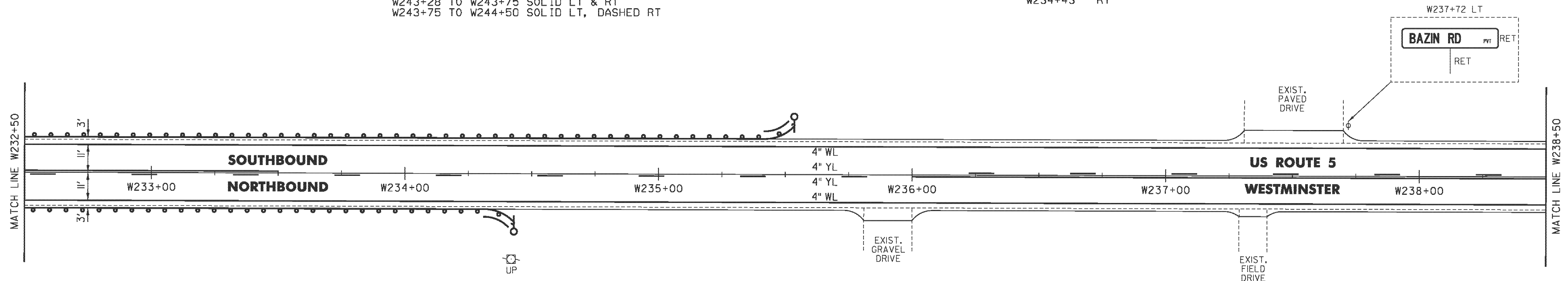

- LEGEND**
- R = REMOVE EXISTING
  - S = SALVAGE
  - R&S = REMOVE AND SALVAGE
  - N = NEW
  - RET = RETAIN
  - B-B = BACK TO BACK
  - = EXISTING GUARDRAIL
  - = PROPOSED GUARDRAIL
  - YL = YELLOW LINE
  - WL = WHITE LINE
  - = DELINEATOR
  - ⊕ = UTILITY POLE

PROJECT NAME: PUTNEY-WESTMINSTER  
 PROJECT NUMBER: STP 2946(1)  
 FILE NAME: zllc344bdr.dgn  
 PROJECT LEADER: P. SHEDD  
 DESIGNED BY: N. LEMAY  
 ROADWAY LAYOUT 58 US 5  
 PLOT DATE: 12/10/2013  
 DRAWN BY: W. GORDON  
 CHECKED BY: P. SHEDD  
 SHEET 79 OF 138

NOT TO SCALE