

**TYPICAL PLAN VIEW
CONCORD AVENUE AARDOT #850-938H**

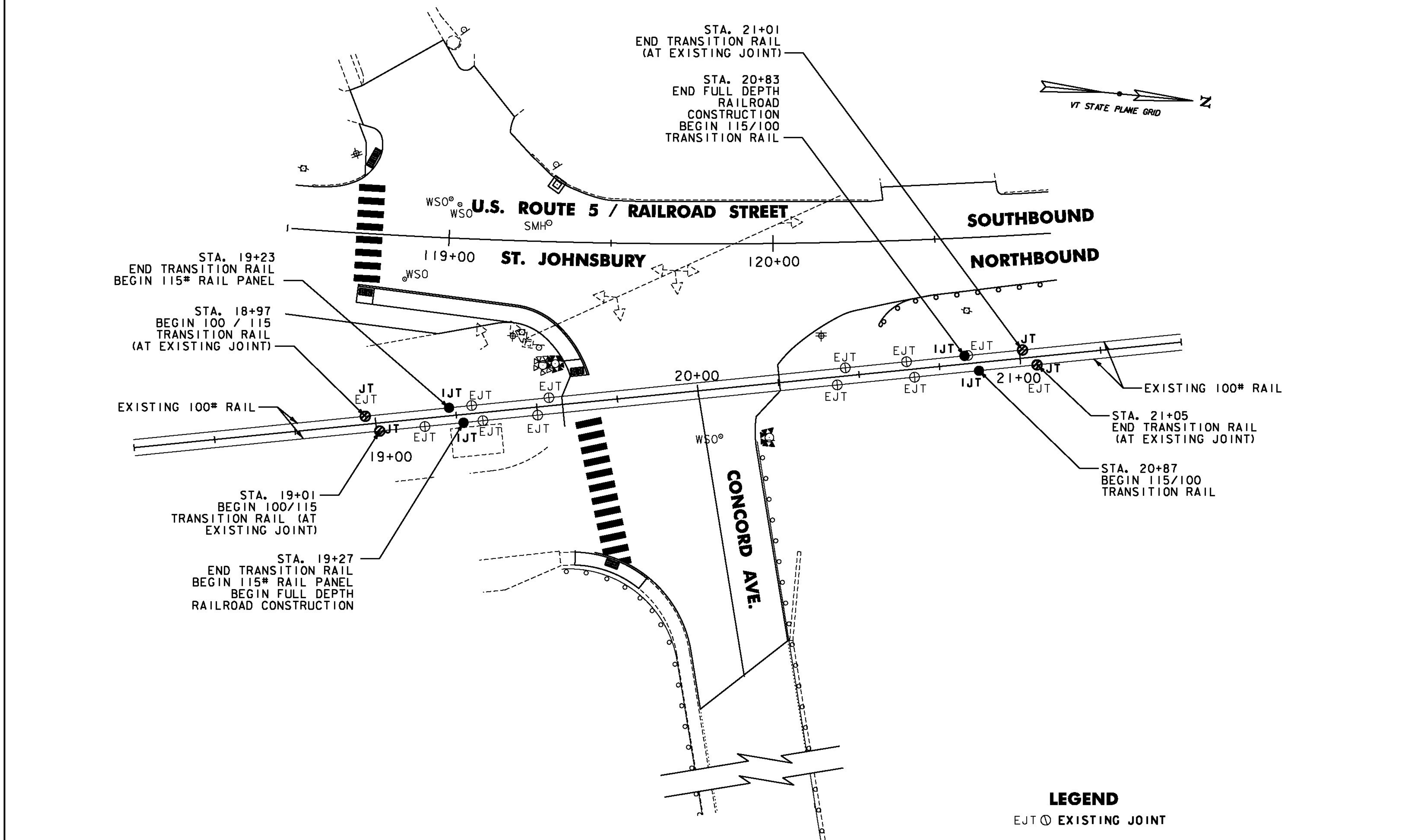

**EXISTING AND PROPOSED RAIL JOINT LAYOUT
CONCORD AVENUE AARDOT #850-938H**

- LEGEND**
- EJT ⊕ EXISTING JOINT
 - IJT ● NEW INSULATED JOINT
 - JT ⊙ NEW JOINT

- NOTES - AARDOT #850-938H**
1. ALL RAIL JOINTS WITHIN THE CROSSING CWR AREA AS SHOWN WILL BE CROPPED AND WELDED IN ACCORDANCE WITH THE LATEST REVISION OF A.R.E.M.A. SPECIFICATIONS AT AN OFF-SITE ELECTRIC WELDING PLANT. WELDING CAN BE DONE IN FIELD UTILIZING THERMITE WELDING WITH ADVANCE APPROVAL FROM THE AGENCY. WELDED JOINTS SHALL BE GROUND TO CONFORM TO THE SHAPE OF THE RAIL ON GAUGE AND FIELD SIDES.
 2. TIE SPACING UNDER CWR AND TRANSITION AREA SHALL BE AS SHOWN. VARIES 18 TO 19.5 INCHES ON CENTER.
 3. TIES IN CROSSING AREA SHALL BE REPLACED AS RECOMMENDED BY THE RAILROAD AND APPROVED BY THE ENGINEER (PAID UNDER ITEM 900.645 SPECIAL PROVISION (RECONSTRUCT RAIL-HIGHWAY CROSSING)). TIES REQUIRED OUTSIDE OF CROSSING AREA SHALL BE PAID AS ITEM 900.620 SPECIAL PROVISION (REMOVAL AND REPLACEMENT OF CROSS TIES).
 4. TIE PLATES SHALL BE NEW 14 INCH PLATES, MANUFACTURED FOR THE RAIL SIZE USED. PLATES SHALL BE INSPECTED AND APPROVED BY THE RAILROAD AND THE ENGINEER. RAIL FASTENERS SHALL BE CUT TRACK SPIKES.
 5. BALLAST OUTSIDE THE FULL DEPTH RAILROAD CONSTRUCTION AREA SHALL EXTEND 12 INCHES MIN. BEYOND END OF TIES AND SLOPED 1:2 TO THE ROADBED. (SEE DETAIL)
 6. TYPE AND DESIGN OF COMMERCIAL FLANGEWAY MATERIALS SHALL RECEIVE APPROVAL FROM THE ENGINEER.
 7. MANUFACTURER'S SPECIFICATIONS SHALL BE FOLLOWED FOR THE INSTALLATION OF COMMERCIAL FLANGEWAY MATERIALS AND INSULATED JOINTS.
 8. CONTRACTOR SHALL ADD BALLAST, LINE, TAMP, AND SURFACE TRACK IN APPROACH AREAS TO OBTAIN A SMOOTH TRANSITION BETWEEN EXISTING AND PROPOSED TRACK TO THE SATISFACTION OF THE ENGINEER AND RAILROAD. THIS WORK WILL BE PAID UNDER ITEM 900.645 SPECIAL PROVISION (RECONSTRUCT RAIL-HIGHWAY CROSSING).
 9. EXCAVATION, UNDERDRAIN, UNDERDRAIN CARRIER PIPE, BALLAST, GEOTEXTILE, FLANGEWAY MATERIALS AND TIES INSIDE CROSSING AREA WILL BE PAID UNDER ITEM 900.645 SPECIAL PROVISION (RECONSTRUCT RAIL-HIGHWAY CROSSING).
 10. SAW CUTTING SHALL NOT BE PAID SEPARATELY BUT BE INCIDENTAL TO ITEM 210.10 COLD PLANING, BITUMINOUS PAVEMENT.
 11. ASPHALTIC PLUG JOINTS WILL BE PAID AS ITEM 516.10 BRIDGE EXPANSION JOINT, ASPHALTIC PLUG.
 12. PREFERRED RAIL LAYING TEMPERATURE (PRLT) SHALL BE BETWEEN 105 DEGREES AND 120 DEGREES FAHRENHEIT.
 13. THE PROPOSED 8 INCH UNDERDRAIN CARRIER PIPE SHALL DAYLIGHT AS SHOWN ON SHEET 37 OR AS DIRECTED BY THE ENGINEER.

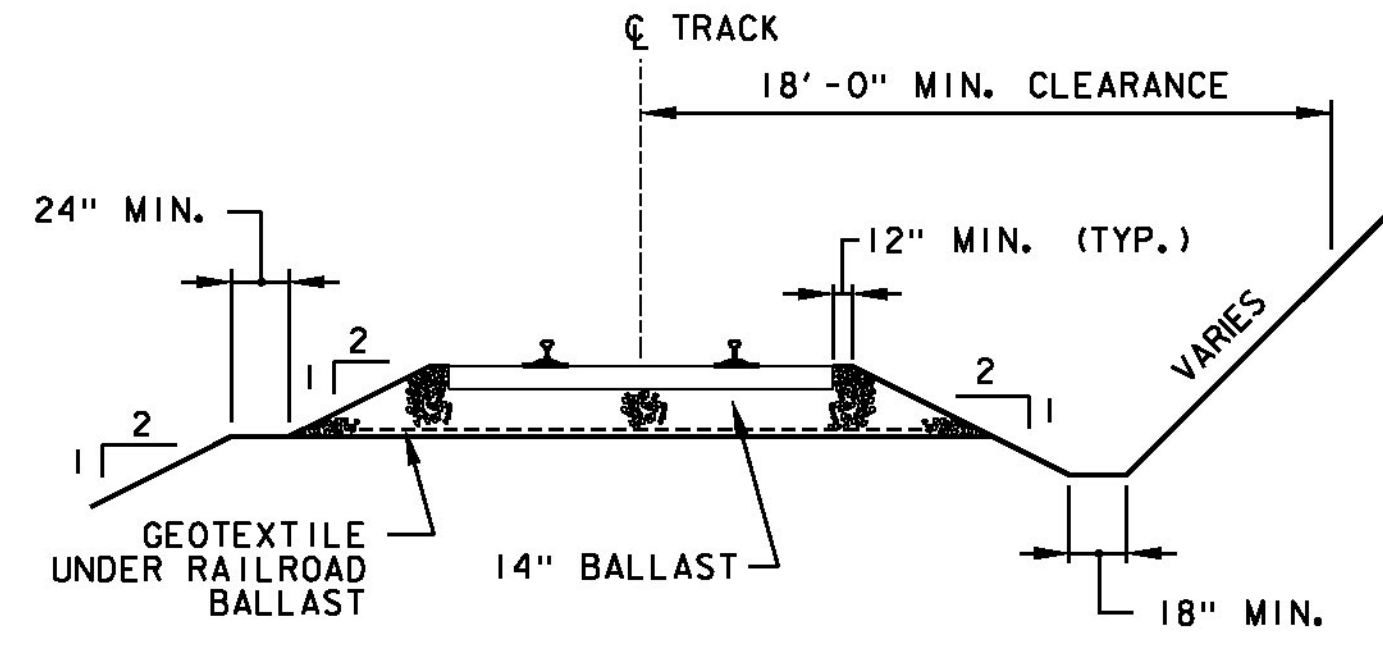

TYPICAL SECTION RAILROAD

NOT TO SCALE		AARDOT #850-938H	
RAILROAD CROSSING DETAIL SHEET #7		PROJECT NAME: ST JOHNSBURY - LYNDON	PROJECT NUMBER: STP 2936(I)
		FILE NAME: pllc308.dgn PROJECT LEADER: G. EDWARDS DESIGNED BY: D. DRAPER	PLOT DATE: 5/5/2014 DRAWN BY: D. DRAPER CHECKED BY: J. LITTLE SHEET 38 OF 250

