

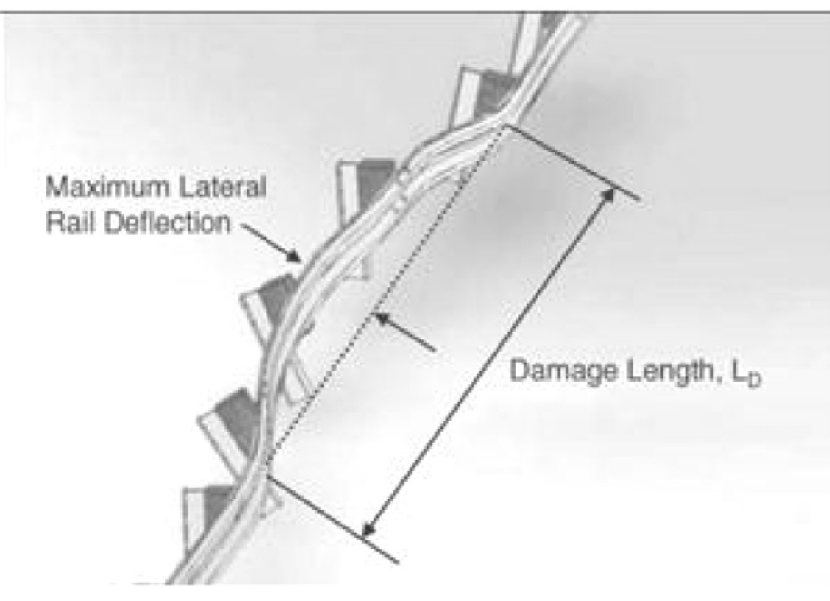
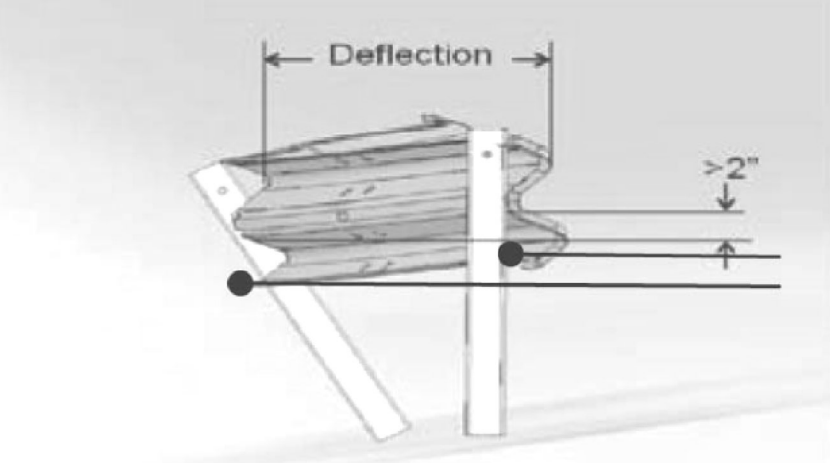
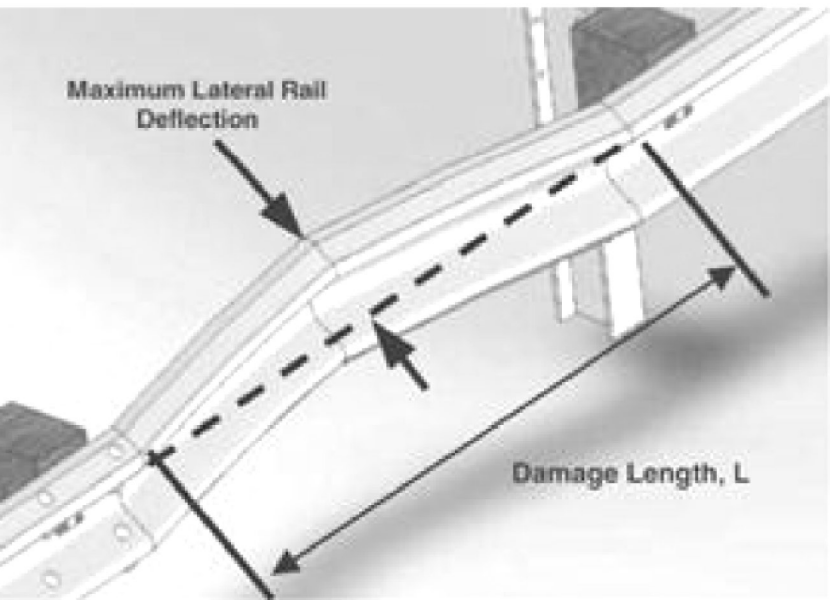
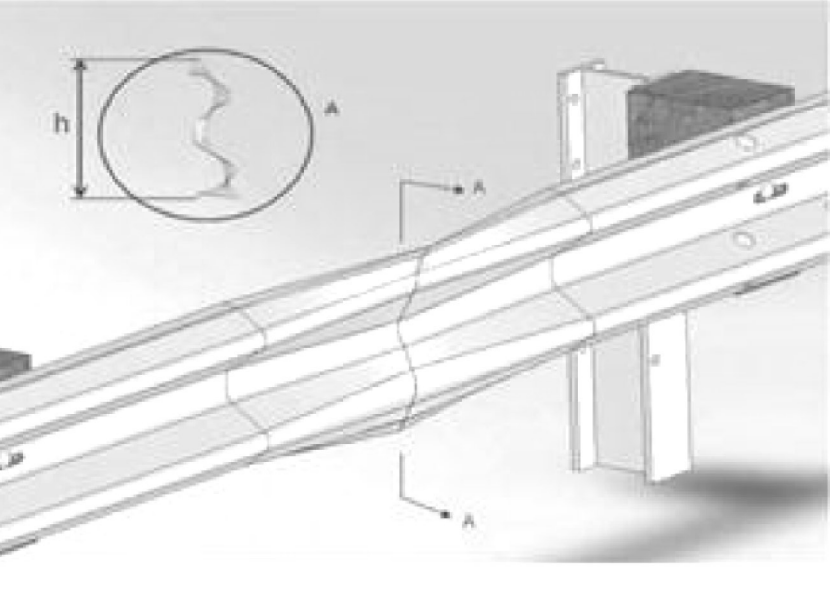
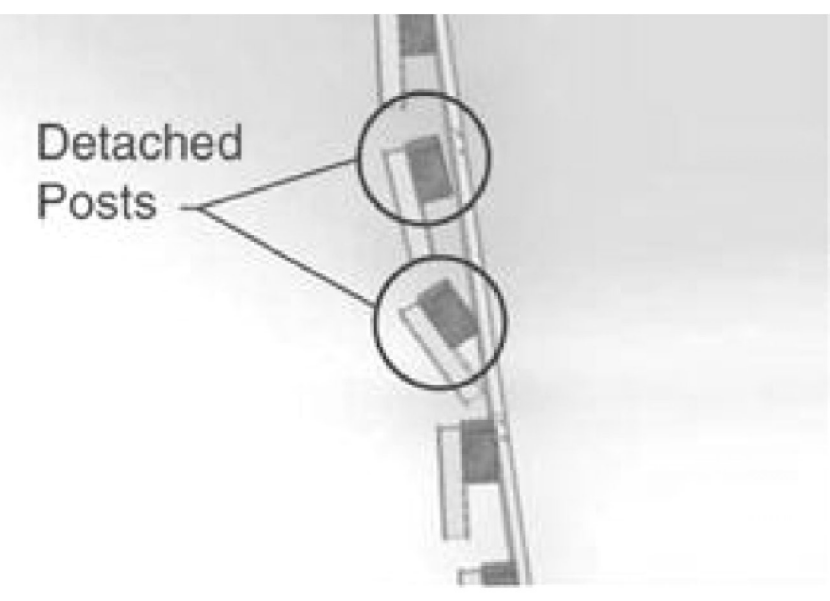
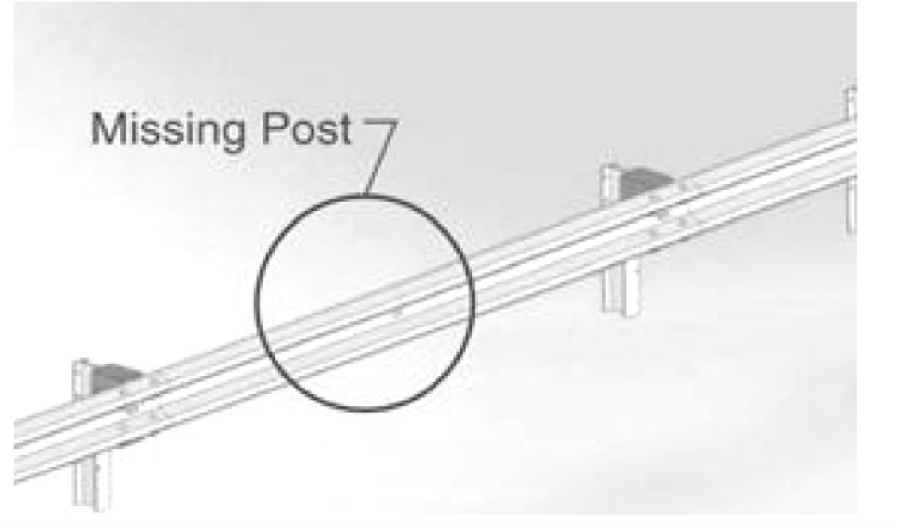
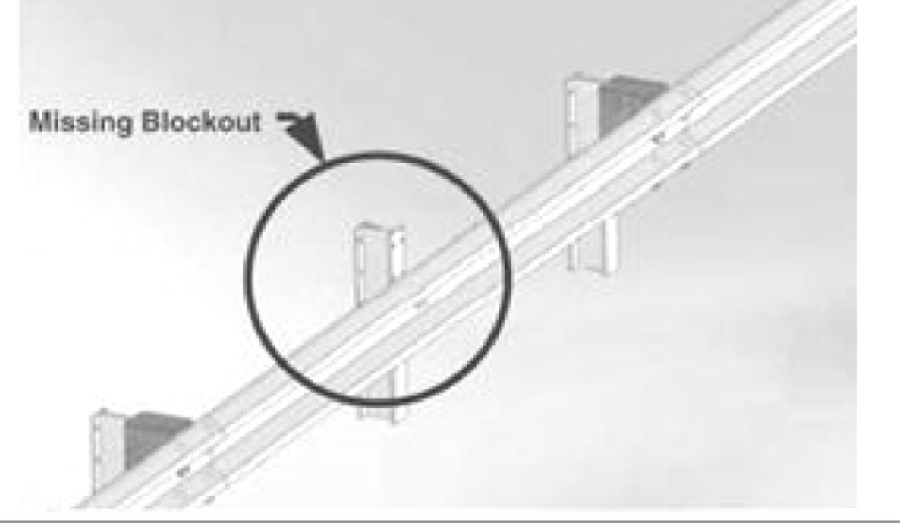
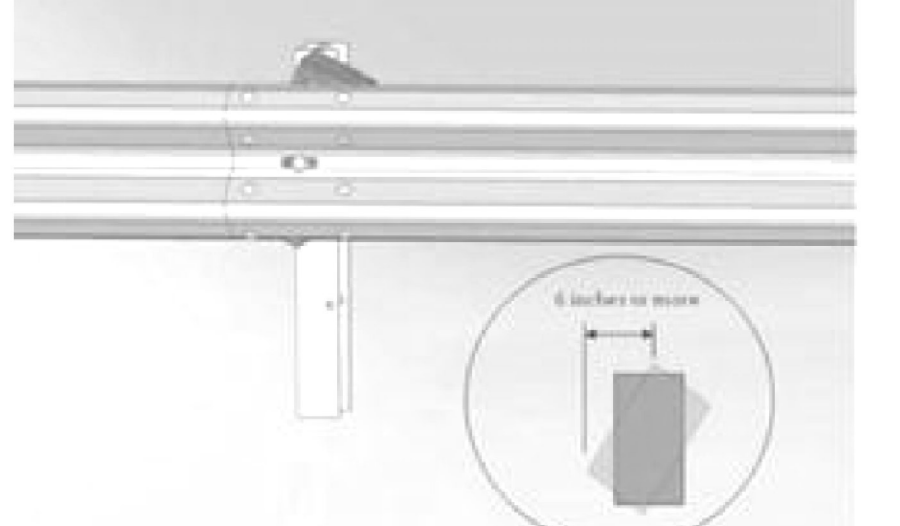

DAMAGE TYPE	REPAIR THRESHOLD	RELATIVE PRIORITY	MEASUREMENT
POST AND RAIL DEFLECTION	ONE OR MORE OF THE FOLLOWING THRESHOLDS: <ul style="list-style-type: none"> <li>MORE THAN 9 IN. OF LATERAL DEFLECTION ANYWHERE OVER A 25 FT LENGTH OF RAILTOP OF RAIL</li> <li>HEIGHT 2 OR MORE IN. LOWER THAN ORIGINAL TOP OF RAIL HEIGHT</li> </ul>	HIGH	
	6 - 9 IN. LATERAL DEFLECTION ANYWHERE OVER A 25-FT LENGTH OF RAIL	MEDIUM	 (WEAK POST W-BEAM SHOWN ONLY FOR CLARITY, EACH MEASUREMENT TAKEN AT THE RAIL'S MIDDLE FOLD)
	LESS THAN 6 IN. OF LATERAL DEFLECTION OVER A 25-FT LENGTH OR RAIL	LOW	
RAIL DEFLECTION ONLY	6 - 9 IN. OF LATERAL DEFLECTION BETWEEN ANY TWO ADJACENT POSTS. NOTE: FOR DEFLECTION OVER 9 IN., USE POST/RAIL DEFLECTION GUIDELINES	MEDIUM	
	LESS THAN 6 IN. OF LATERAL DEFLECTION BETWEEN ANY TWO ADJACENT POSTS	LOW	
RAIL FLATTENING	ONE OR MORE OF THE FOLLOWING THRESHOLDS: <ul style="list-style-type: none"> <li>RAIL CROSS SECTION HEIGHT MORE THAN 17 IN. (SUCH AS MAY OCCUR IF RAIL IS FLATTENED)</li> <li>RAIL CROSS SECTION HEIGHT LESS THAN 9 IN. (SUCH AS A DENT TO TOP EDGE)</li> </ul>	MEDIUM	
	* SEE NOTE 3 THIS SHEET. RAIL CROSS SECTION HEIGHT BETWEEN 9 AND 17 IN.	LOW	
POSTS SEPARATED FROM RAIL	<ul style="list-style-type: none"> <li>2 OR MORE POSTS WITH BLOCKOUT ATTACHED WITH POST/RAIL SEPARATION LESS THAN 3 IN.</li> <li>1 OR MORE POSTS WITH POST/RAIL SEPARATION WHICH EXCEEDS 3 IN.</li> </ul>	MEDIUM	 NOTE: 1. IF THE BLOCKOUT IS NOT FIRMLY ATTACHED TO THE POST, USE THE MISSING BLOCKOUT GUIDELINES. 2. DAMAGE SHOULD ALSO BE EVALUATED AGAINST POST/RAIL DEFLECTION GUIDELINES.
	<ul style="list-style-type: none"> <li>1 POST, WITH BLOCKOUT ATTACHED, WITH POST/RAIL SEPARATION LESS THAN 3 IN.</li> </ul>	LOW	

DAMAGE TYPE	REPAIR THRESHOLD	RELATIVE PRIORITY	MEASUREMENT
MISSING/BROKEN POSTS	1 OR MORE POSTS <ul style="list-style-type: none"> <li>MISSING</li> <li>CRACKED ACROSS THE GRAIN</li> <li>BROKEN</li> <li>ROTTED</li> <li>WITH METAL TEARS</li> </ul>	HIGH	
MISSING BLOCKOUT	ANY BLOCKOUTS <ul style="list-style-type: none"> <li>MISSING</li> <li>CRACKED ACROSS THE GRAIN</li> <li>CRACKED FROM TOP OR BOTTOM OF BLOCKOUT THROUGH POST BOLT HOLE</li> <li>ROTTED</li> </ul>	MEDIUM	
TWISTED BLOCKOUTS	ANY MISALIGNED BLOCKOUTS, TOP EDGE OF BLOCK 6 IN. OR MORE FROM BOTTOM EDGE  NOTE: REPAIRS OF TWISTED BLOCKOUT ARE RELATIVELY QUICK AND INEXPENSIVE	LOW	
DAMAGE AT A RAIL SPLICE	MORE THAN 1 SPLICE BOLT: <ul style="list-style-type: none"> <li>MISSING</li> <li>DAMAGED</li> <li>VISIBLY MISSING ANY UNDERLYING RAIL</li> <li>TORN THROUGH RAIL</li> </ul>	HIGH	
	1 SPLICE BOLT: <ul style="list-style-type: none"> <li>MISSING</li> <li>DAMAGED</li> <li>VISIBLY MISSING ANY UNDERLYING RAIL</li> <li>TORN THROUGH RAIL</li> </ul>	MEDIUM	
NON-MANUFACTURED HOLE (SUCH AS CRASH-INDUCED HOLES, LUG-NUT DAMAGE, OR HOLES RUSTED-THROUGH THE RAIL)	<ul style="list-style-type: none"> <li>MORE THAN 2 HOLES LESS THAN 1IN. HEIGHT IN A 12.5-FT LENGTH OF RAIL</li> <li>ANY HOLES GREATER THAN 1IN. IN HEIGHT</li> <li>ANY HOLE WHICH INTERSECTS EITHER THE TOP OR BOTTOM EDGE OF THE RAIL</li> </ul>	HIGH	
	1 - 2 HOLES LESS THAN 1IN. IN HEIGHT IN A 12.5-FT LENGTH OF RAIL	MEDIUM	

NOTES:

- THESE ARE GUIDELINES FOR THE EVALUATION OF EXISTING GUARDRAIL. THESE ARE GUIDELINES ONLY AND THE CONTRACTOR SHALL REPLACE GUARDRAIL AS DIRECTED BY THE ENGINEER.
- GUIDELINES ARE FROM THE NATIONAL HIGHWAY RESEARCH PROGRAM (NCHRP) REPORT 656, "CRITERIA FOR RESTORATION OF LONGITUDINAL BARRIERS", COPYRIGHT 2010.
- WHEN GUARDRAIL IS TO BE REMOVED AND RESET, PANELS WITH A RAIL CROSS SECTION HEIGHT OF 15 INCHES OR GREATER SHALL BE REPLACED

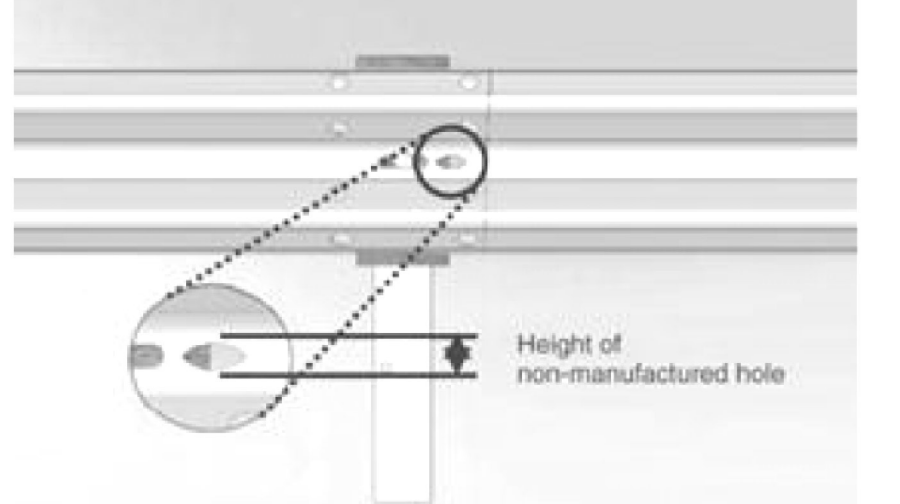
NOT TO SCALE

PROJECT NAME: BERLIN-BARRE TOWN/NORTHFIELD-WILLIAMSTOWN/BROOKFIELD	
PROJECT NUMBER: STP 2943(1)/STP 2959(1)/STP 2960(1)	
FILE NAME: z11b338composite.dgn	PLOT DATE: 4/26/2016
PROJECT LEADER: C. LATHROP	DRAWN BY: O. DALMER
DESIGNED BY: S. SOLLA	CHECKED BY: C. LATHROP
GUARDRAIL REPLACEMENT GUIDELINES SHEET 1	SHEET 12 OF 202