

# PRELIMINARY INFORMATION SHEET (BRIDGE)

**LRFD**

**INDEX OF SHEETS**

**FINAL HYDRAULIC REPORT**

**PLAN SHEETS**

1	TITLE SHEET	B-5
2	PRELIMINARY INFORMATION SHEET	B-71
3	CONVENTIONAL SYMBOLS LEGEND SHEET	D-3
4	TYPICAL SECTIONS	D-4
5	TYPICAL EARTHWORK SECTIONS	E-134
6	DETAIL SHEET	G-1
7 - 8	TIE SHEETS	G-1d
9	BORING INFORMATION SHEET	G-19
10	BORING LOGS	J-3
11 - 12	QUANTITY SHEETS	T-1
13	EARTHWORK SHEET	T-10
14 - 15	RIGHT-OF-WAY SHEETS	T-17
16	ROADWAY PLAN SHEET	T-28
17	VT 14 PROFILE	T-30
18	EPSC NARRATIVE	T-35
19	EPSC EXISTING CONDITIONS PLAN SHEET	T-45
20	EPSC CONSTRUCTION PLAN SHEET	
21	EPSC FINAL CONDITIONS PLAN SHEET	
22 - 24	EPSC DETAIL SHEETS	
25	CULVERT PLAN AND ELEVATION	
26	PROJECT NOTES	
27	STRUCTURE DETAILS	
28	BOX LAYOUT	
29 - 32	VT 14 CROSS SECTION SHEETS	
33 - 36	CHANNEL CROSS SECTION SHEETS	
37	TRAFFIC CONTROL TYPICAL SECTIONS	
38	TRAFFIC CONTROL PLAN	
39	TRAFFIC CONTROL PROFILE	
40 - 42	TRAFFIC CONTROL CROSS SECTION SHEETS	
43	TRAFFIC CONTROL SIGN PLAN	

**STANDARDS LIST**

06-01-1994	B-5
07-08-2005	B-71
06-01-1994	D-3
08-13-2007	D-4
08-08-1995	E-134
01-03-2000	G-1
01-03-2000	G-1d
11-15-2002	G-19
08-07-1995	J-3
08-06-2012	T-1
08-06-2012	T-10
08-06-2012	T-17
08-06-2012	T-28
08-06-2012	T-30
08-06-2012	T-35
01-02-2013	T-45

**HYDROLOGIC DATA**

Date: Feb. 2012

DRAINAGE AREA : 0.6 sq. mi.  
 CHARACTER OF TERRAIN : Hilly, a mixture of developed, open and forested land cover  
 STREAM CHARACTERISTICS : Long pipe upstream. Steep, confined banks downstream.  
 NATURE OF STREAMBED : Sand, gravel and stones

**PEAK FLOW DATA**

Q 2.33 =	70 cfs	Q 50 =	190 cfs
Q 10 =	130 cfs	Q 100 =	210 cfs
Q 25 =	160 cfs	Q 500 =	300 cfs

DATE OF FLOOD OF RECORD : Unknown  
 ESTIMATED DISCHARGE : Unknown  
 WATER SURFACE ELEV. : Unknown  
 NATURAL STREAM VELOCITY : @ Q50 = 11.3 fps  
 ICE CONDITIONS : Slight  
 DEBRIS : Slight  
 DOES THE STREAM REACH MAXIMUM HIGHWATER ELEV. RAPIDLY? : Yes  
 IS ORDINARY RISE RAPID? : Yes  
 IS STAGE AFFECTED BY UPSTREAM OR DOWNSTREAM CONDITIONS? : No  
 IF YES, DESCRIBE :

WATERSHED STORAGE : < 1% HEADWATERS :  
 UNIFORM : X  
 IMMEDIATELY ABOVE SITE :

**EXISTING STRUCTURE INFORMATION**

STRUCTURE TYPE : Stone and concrete box  
 YEAR BUILT : Unknown  
 CLEAR SPAN(NORMAL TO STREAM) : 3'  
 VERTICAL CLEARANCE ABOVE STREAMBED : 3'  
 WATERWAY OF FULL OPENING : 9 sq. ft.  
 DISPOSITION OF STRUCTURE : Remove  
 TYPE OF MATERIAL UNDER SUBSTRUCTURE : Unknown

**WATER SURFACE ELEVATIONS AT:**

Q2.33 =	662.0'	VELOCITY =	9.1 fps
Q10 =	668.1'	"	14.4 fps
Q25 =	671.1'	"	16.6 fps
Q50 =	671.4'	"	16.7 fps
Q100 =	671.5'	"	16.8 fps

LONG TERM STREAMBED CHANGES : None known

IS THE ROADWAY OVERTOPPED BELOW Q100 : Yes  
 FREQUENCY : Below Q25  
 RELIEF ELEVATION : 670.8'  
 DISCHARGE OVER ROAD @Q100 : 60 cfs

**UPSTREAM STRUCTURE**

TOWN : Barre Town DISTANCE : 10'  
 HIGHWAY # : Private pipe under lawn STRUCTURE # : Private  
 CLEAR SPAN : 3.5' CLEAR HEIGHT : 3.5'  
 YEAR BUILT : Unknown FULL WATERWAY : 9.6 sq. ft.  
 STRUCTURE TYPE : CPEP (SL)

**DOWNSTREAM STRUCTURE**

TOWN : Barre Town DISTANCE : 150'  
 HIGHWAY # : Confluence with Stevens Branch STRUCTURE # :  
 CLEAR SPAN : CLEAR HEIGHT :  
 YEAR BUILT : FULL WATERWAY :  
 STRUCTURE TYPE :

**LRFR LOAD RATING FACTORS \***

LOADING LEVELS	TRUCK						
	H-20	HL-93	3S2	6 AXLE	3A STR	4A STR	5A SEMI
TONNAGE	20	36	36	66	30	34.5	38
INVENTORY							
POSTING							
OPERATING							
COMMENTS:							

**AS BUILT "REBAR" DETAIL**

LEVEL I	LEVEL II	LEVEL III
TYPE:	TYPE:	TYPE:
GRADE:	GRADE:	GRADE:

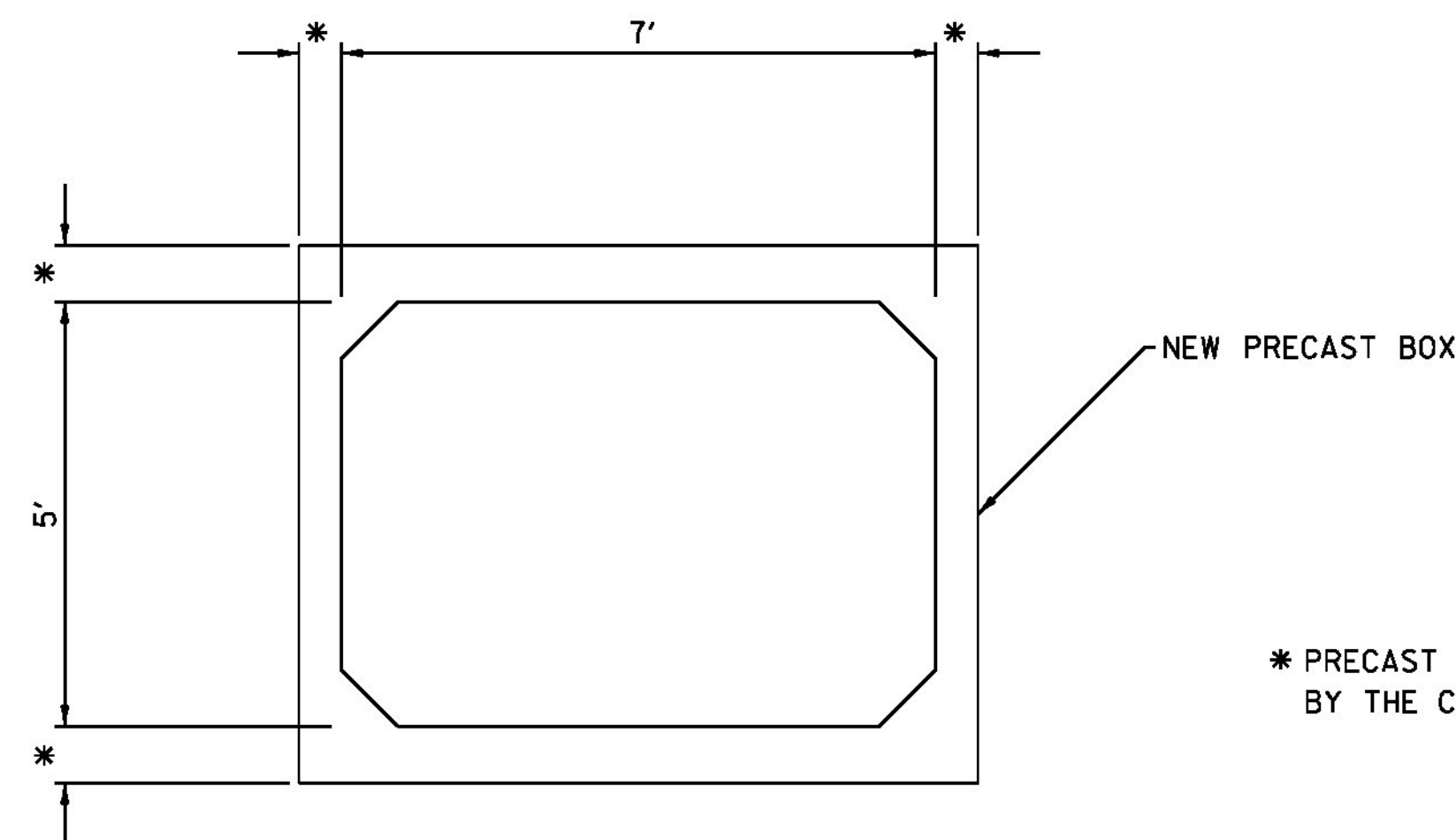

**PRECAST BOX CULVERT**

NOT TO SCALE

**TRAFFIC DATA**

YEAR	ADT	DHV	% D	% T	ADTT
2012	9200	970	52	5.2	590
2032	9300	980	52	7.2	840

20 year ESAL for flexible pavement from 2012 to 2032 : 3902000  
 40 year ESAL for flexible pavement from 2012 to 2052 : 8320000  
 Design Speed : 35 mph

**PROPOSED STRUCTURE**

STRUCTURE TYPE : Precast concrete box  
 CLEAR SPAN(NORMAL TO STREAM) : 7'  
 VERTICAL CLEARANCE ABOVE STREAMBED : 5'  
 WATERWAY OF FULL OPENING : 35 sq. ft.

**WATER SURFACE ELEVATIONS AT:**

Q2.33 =	660.4'	VELOCITY =	13.5 fps
Q10 =	661.6'	"	15.4 fps
Q25 =	662.2'	"	16.0 fps
Q50 =	662.7'	"	16.6 fps
Q100 =	663.1'	"	16.9 fps

IS THE ROADWAY OVERTOPPED BELOW Q100 : No  
 FREQUENCY : Above Q100  
 RELIEF ELEVATION : 671.2'  
 DISCHARGE OVER ROAD @Q100 : None

AVERAGE LOW ELEVATION OF SUPERSTRUCTURE : Inside top of box 663.0' at inlet  
 VERTICAL CLEARANCE : @ Q50 = 0.3'

SCOUR : Not applicable for a box.

REQUIRED CHANNEL PROTECTION : See below.\*

**PERMIT INFORMATION**

AVERAGE DAILY FLOW : 1 cfs DEPTH OR ELEVATION :  
 ORDINARY LOW WATER : 0.5 cfs Depth < 0.5'  
 ORDINARY HIGH WATER : 30 cfs Depth = 2.0'

**TEMPORARY BRIDGE REQUIREMENTS**

STRUCTURE TYPE : No temporary structure needed.  
 CLEAR SPAN (NORMAL TO STREAM) :  
 VERTICAL CLEARANCE ABOVE STREAMBED :  
 WATERWAY AREA OF FULL OPENING :

**ADDITIONAL INFORMATION**

\*Use Stone Fill, Type III on the stream bed and up the channel banks to 5' above stream bed, or to the top of bank. Smaller stone may be used for slope protection from that point up as needed and as shown on the plans.

**DESIGN VALUES**

1. DESIGN LIVE LOAD	HL-93
2. FUTURE PAVEMENT	dp: 2.0 INCH
3. DESIGN SPAN	L: 7.00 FT
4. MIN. MID-SPAN POS. CAMBER @ RELEASE (PRESTRESSED UNITS)	Δ: ---
5. PRESTRESSING STRAND	fy: ---
6. PRESTRESSED CONCRETE STRENGTH	f'c: ---
7. PRESTRESSED CONCRETE RELEASE STRENGTH	f'cr: ---
8. CONCRETE, HIGH PERFORMANCE CLASS AA	f'c: 4.0 KSI
9. CONCRETE, HIGH PERFORMANCE CLASS A	f'c: 4.0 KSI
10. CONCRETE, HIGH PERFORMANCE CLASS B	f'c: 3.5 KSI
11. CONCRETE, CLASS C	f'c: 3.0 KSI
12. REINFORCING STEEL	fy: 60 KSI
13. STRUCTURAL STEEL AASHTO M270	fy: ---
14. SOIL UNIT WEIGHT	γ: 0.140 KCF
15. NOMINAL BEARING RESISTANCE OF SOIL	qn: 4.0 KSF
16. SOIL BEARING RESISTANCE FACTOR (REFER TO AASHTO LRFD)	φ: 0.45
17. NOMINAL BEARING RESISTANCE OF ROCK	qn: 10.0 KSF
18. ROCK BEARING RESISTANCE FACTOR (REFER TO AASHTO LRFD)	φ: 0.45
19. NOMINAL AXIAL PILE RESISTANCE	qp: ---
20. PILE YIELD STRENGTH ASTM A572	fy: ---
21. PILE SIZE	---
22. EST. PILE LENGTH	Lp: ---
23. PILE RESISTANCE FACTOR	φ: ---
24. LATERAL PILE DEFLECTION	Δ: ---
25. BASIC WIND SPEED	V3s: ---
26. MINIMUM GROUND SNOW LOAD	ps: ---
27. SEISMIC DATA	PGA: --- S: ---

PROJECT NAME : BARRE TOWN  
 PROJECT NUMBER : STP SCR(P)O

FILE NAME : z10d202pl.dgn PLOT DATE : 2/13/2014  
 PROJECT LEADER : K. UPMAL DRAWN BY : M. SMITH  
 DESIGNED BY : S. BEAUMONT CHECKED BY : J. BYATT  
 PRELIMINARY INFORMATION SHEET SHEET 2 OF 43

\* LRFR LOAD RATING FACTORS TABLE TO BE COMPLETED BY CONTRACTOR'S DESIGNER.