

ABUTMENT NO 2 FOOTING MASONRY PLAN

SCALE 1/4" = 1'-0"

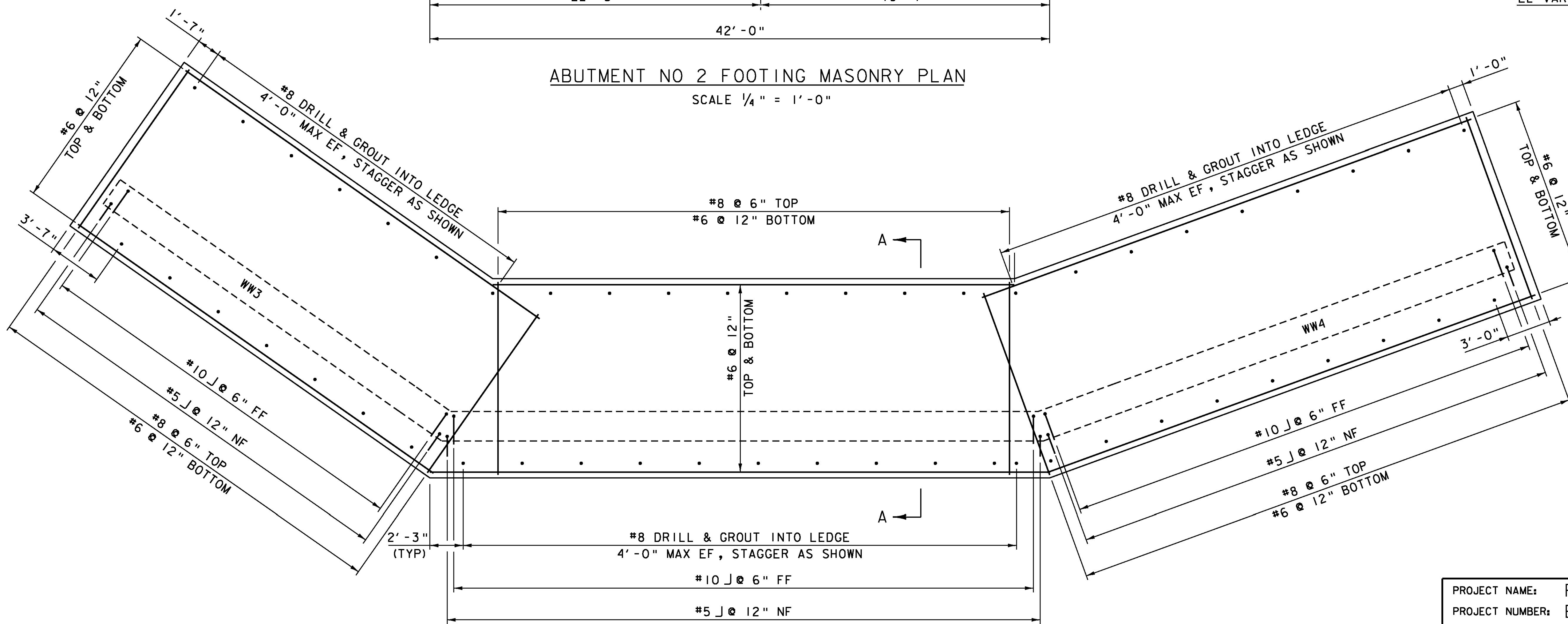

ABUTMENT NO 2 FOOTING REINFORCING PLAN

SCALE 1/4" = 1'-0"

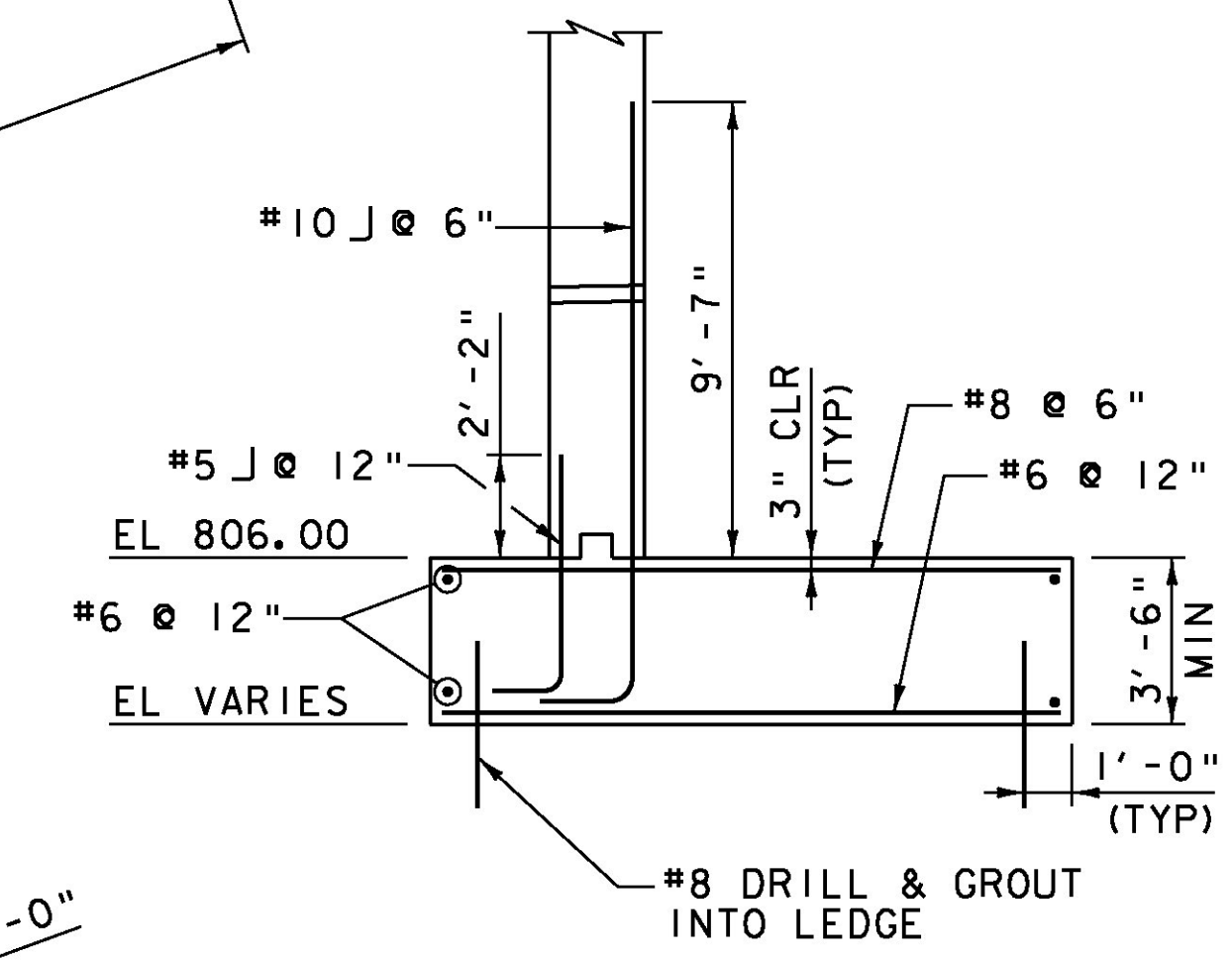

SECTION A-A

SCALE 1/4" = 1'-0"

**NOTE:**  
 NF = NEAR FACE  
 FF = FAR FACE  
 EF = EACH FACE  
 ▲ = CUT TO FIT IN FIELD  
 3" CLEAR, UNLESS OTHERWISE SPECIFIED ON THE PLANS.  
 2'-2" BAR LAP UNLESS OTHERWISE SPECIFIED ON THE PLANS.

PROJECT NAME:	ROCHESTER
PROJECT NUMBER:	ER BRF 0162(18)
FILE NAME:	zllc332sub.dgn
PROJECT LEADER:	S.E. BURBANK
DESIGNED BY:	J.T. KLEIN
BR 19 ABUTMENT NO 2 FOOTING	
PLOT DATE:	8/19/2013
DRAWN BY:	B.J. MASSE
CHECKED BY:	S.E. BURBANK
SHEET	212 OF 238

