

SECTION A-A
SCALE 1" = 1'-0"

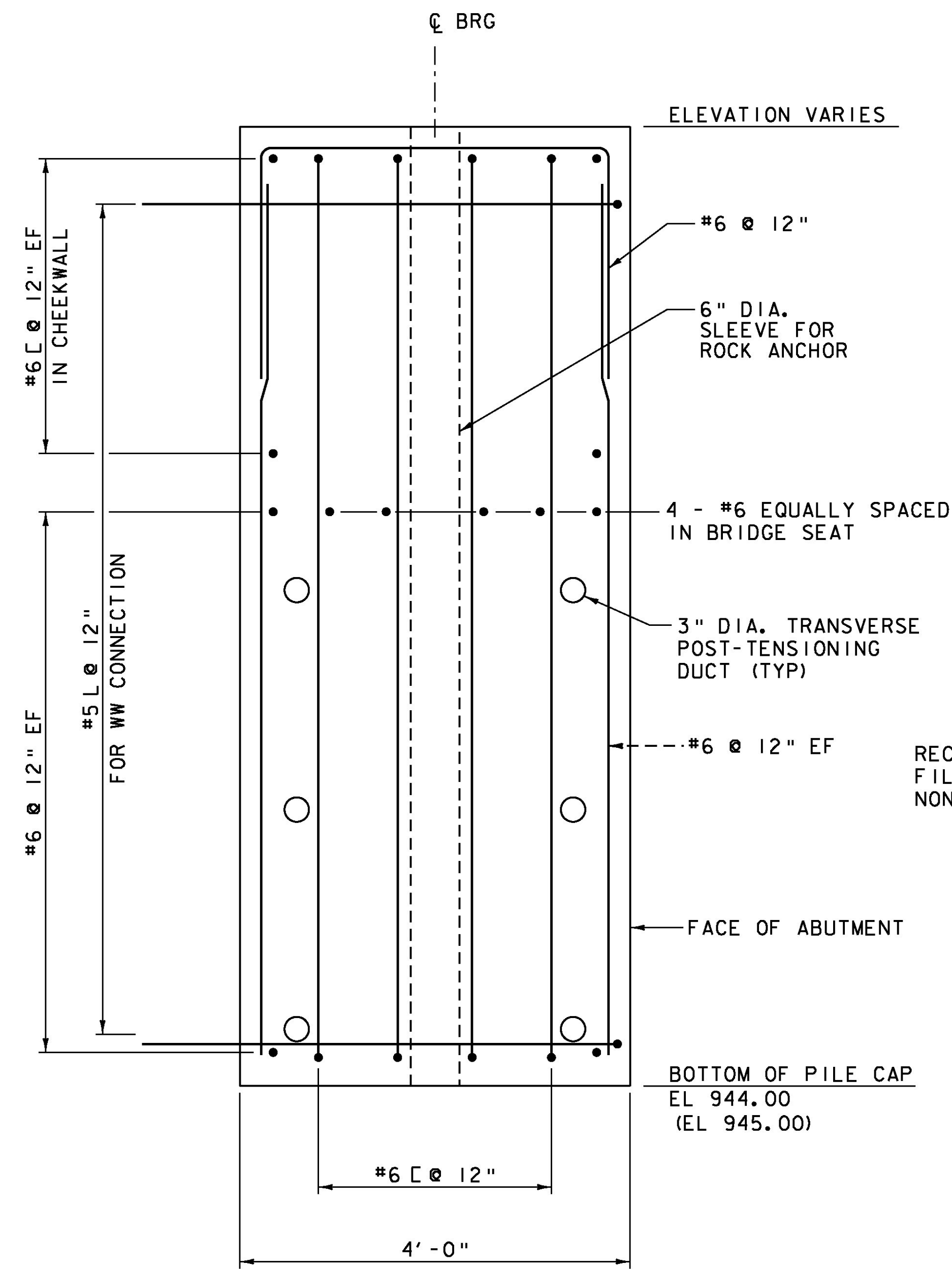

SECTION B-B
SCALE 1" = 1'-0"

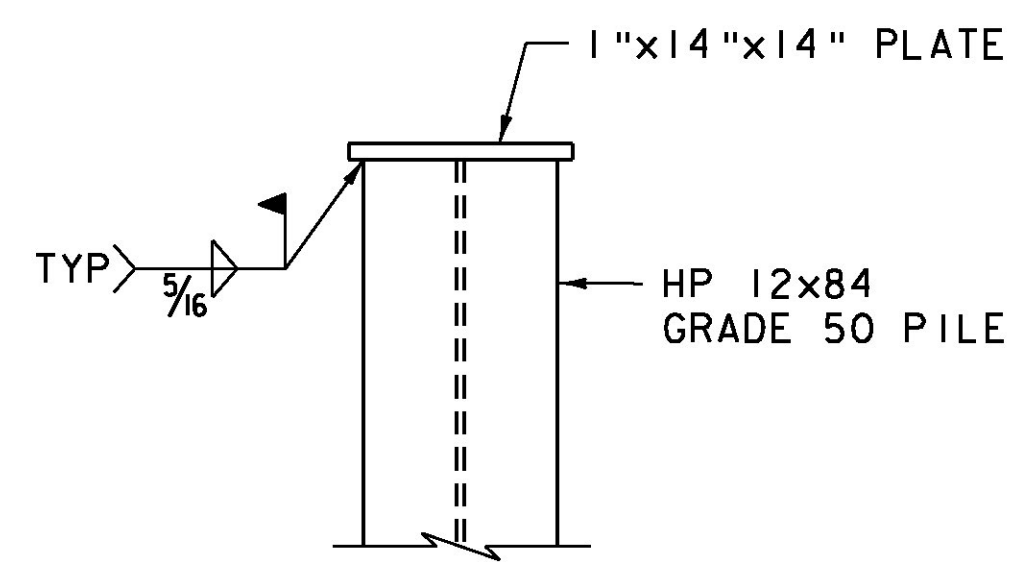

PILE PLATE
SCALE 1" = 1'-0"

NOTE:
NF = NEAR FACE
FF = FAR FACE
EF = EACH FACE
▲ = CUT TO FIT IN FIELD
3" CLEAR, UNLESS OTHERWISE SPECIFIED ON THE PLANS.
2'-2" BAR LAP UNLESS OTHERWISE SPECIFIED ON THE PLANS.

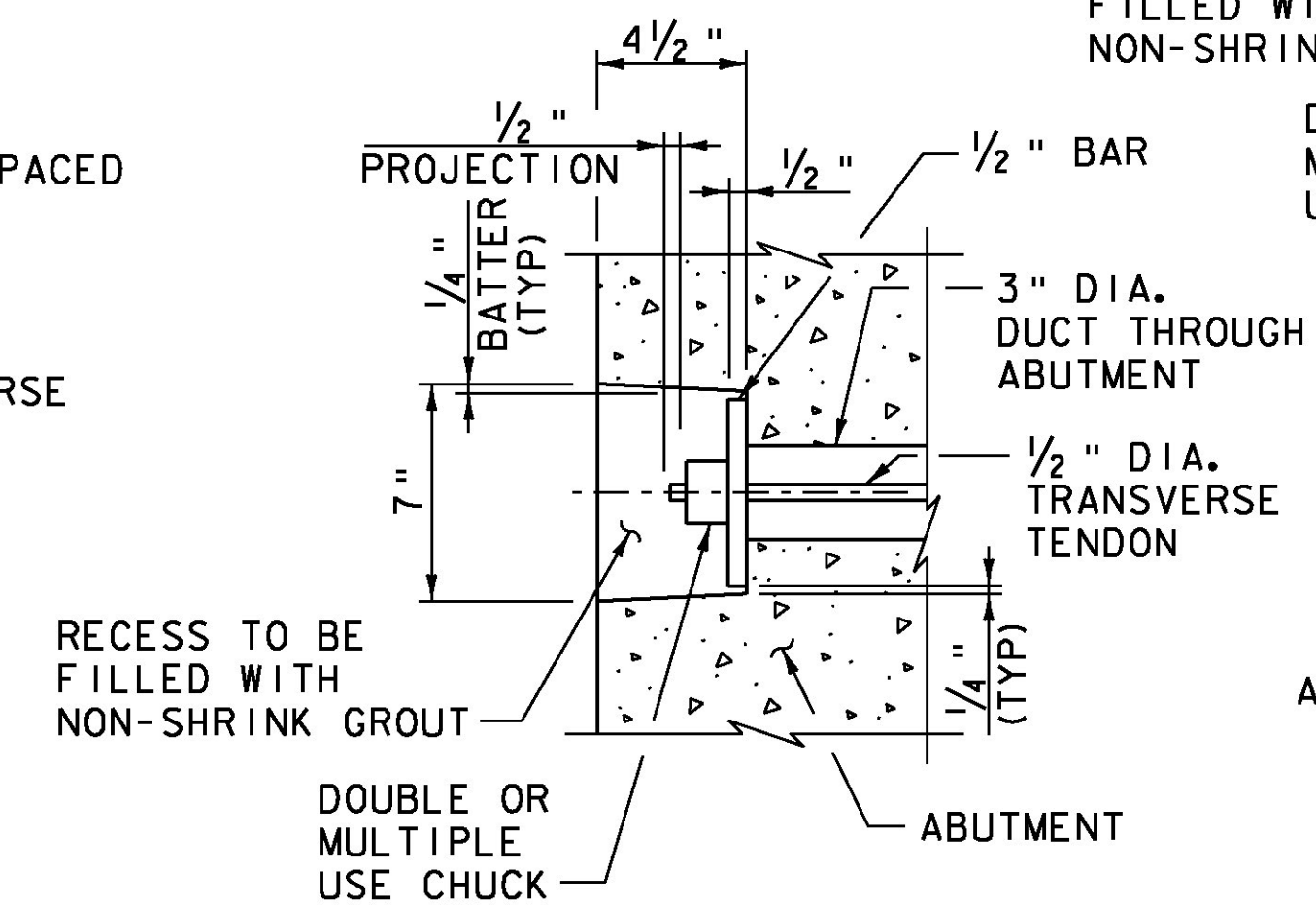
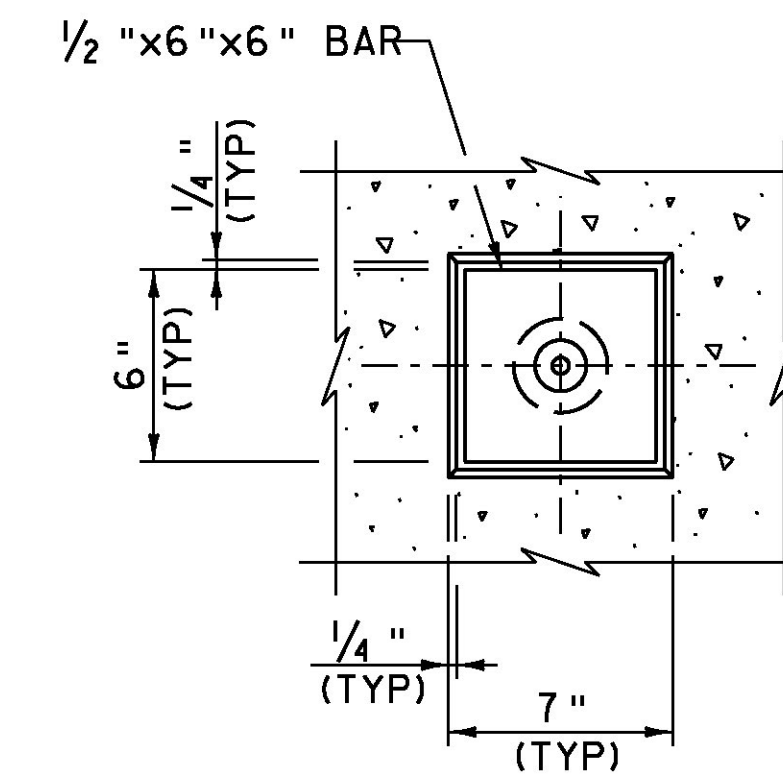

TRANSVERSE TENDON DETAIL
NOT TO SCALE

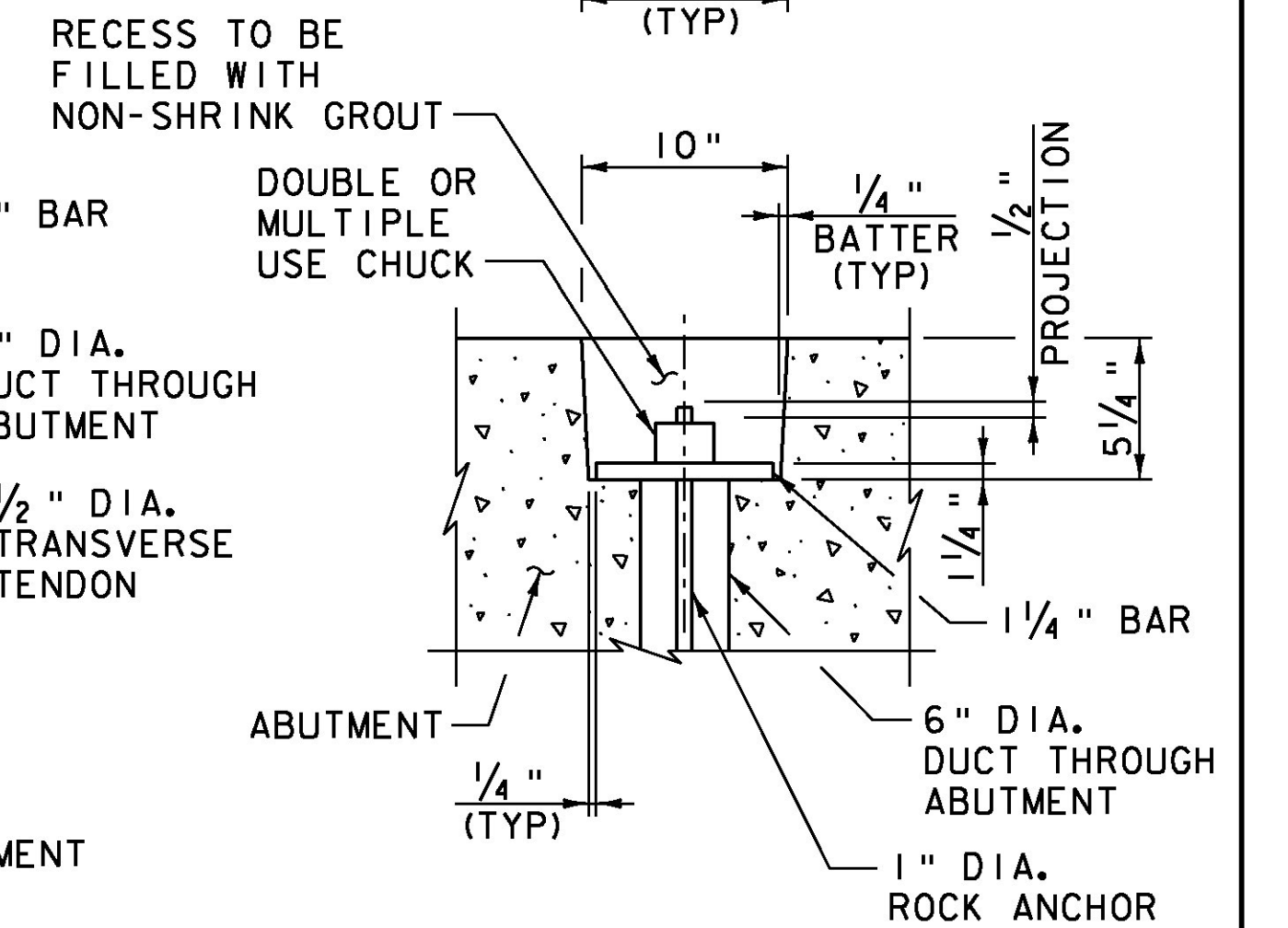
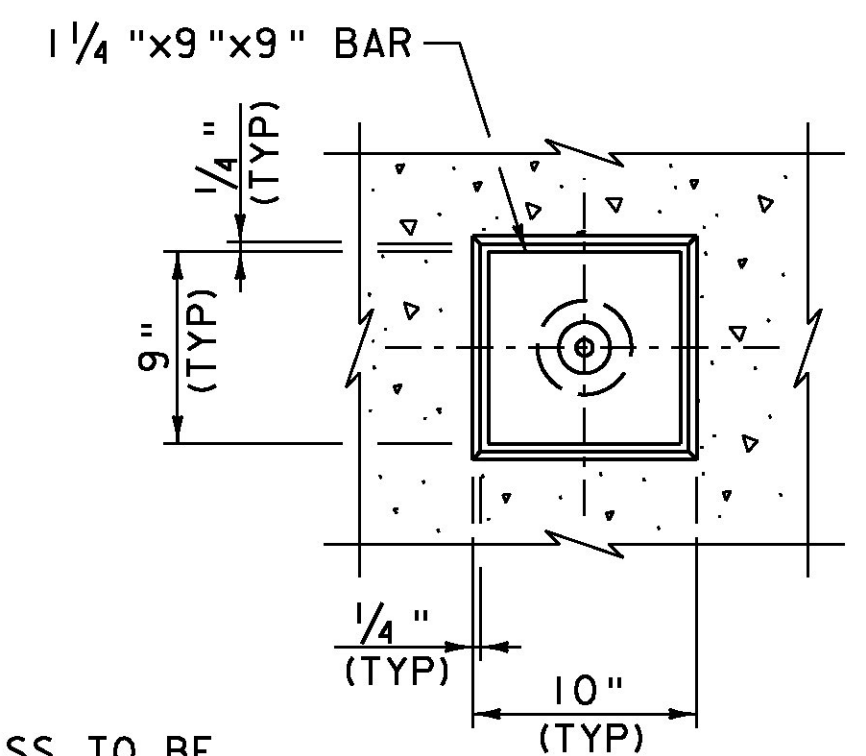

ROCK ANCHOR DETAIL
NOT TO SCALE

TRANSVERSE TENDON AND ROCK ANCHOR NOTES:

1. MORTAR FOR EXTERIOR POCKETS SHALL BE THE SAME COLOR AND TEXTURE AS THE ABUTMENT CONCRETE.
2. OTHER ANCHORAGE SYSTEMS MAY BE SUBSTITUTED WITH THE APPROVAL OF THE ENGINEER. ALTERNATE ANCHORAGE SYSTEMS SHALL BE WATER TIGHT AND CORROSION PROOF.
3. TRANSVERSE TENDONS AND ROCK ANCHORS SHALL BE COVERED BY A SEAMLESS POLYPROPYLENE SHEATH (WITH CORROSION INHIBITING GREASE BETWEEN THE STRAND/ANCHOR AND THE SHEATH) FOR THE FULL LENGTH OF THE TENDON/ANCHOR, EXCEPT AT THE ANCHORAGE LOCATION.
4. ORIENT ROCK ANCHOR BAR AND POCKET PARALLEL TO WINGWALL.

NOTES:

1. ABUTMENTS SHALL BE PRECAST CONCRETE ACCORDING TO SECTION 540.
2. ONCE PILES HAVE BEEN CUT TO THEIR FINAL ELEVATIONS, 1"x16"x16" STEEL PLATES SHALL BE WELDED TO THE TOP OF THE PILES. PAYMENT FOR THE PLATES SHALL BE INCIDENTAL TO ITEM 505.165, "STEEL PILING, HP 12x84".
3. PILE CAVITY GROUT DUCTS (FILL AND VENT) SHALL BE CORRUGATED.
4. SEE PROJECT NOTES FOR ADDITIONAL FABRICATION, CONSTRUCTION, AND SEQUENCE NOTES.
5. ELEVATIONS SHOWN FOR ABUTMENT NO 1. ELEVATIONS FOR ABUTMENT NO 2 SHOWN IN PARENTHESIS.



PROJECT NAME: ROCHESTER	PLOT DATE: 8/19/2013
PROJECT NUMBER: BRF 0162(17)	DRAWN BY: B.J. MASSE
FILE NAME: z85e035sub.dgn	DESIGNED BY: E.A. FIALA
PROJECT LEADER: G.S. GOODRICH	CHECKED BY: L.S. CHERVINCKY
BR 16 ABUTMENT DETAILS	SHEET 158 OF 238