

TEMPORARY 4 INCH WHITE LINE, PAINT
 DURABLE 4 INCH WHITE LINE (OPTION ITEM)
 N 425+50 TO N 431+50 SOLID LT & RT

TEMPORARY 4 INCH YELLOW LINE, PAINT
 DURABLE 4 INCH YELLOW LINE, EPOXY PAINT OR
 DURABLE 4 INCH YELLOW LINE, POLYUREA (OPTION ITEM)
 N 425+50 TO N 430+05 SOLID LT, DASHED RT
 N 430+05 TO N 431+50 DASHED CL

STEEL BEAM GUARDRAIL, GALVANIZED
 N 422+85.5 RT (12.5')

REMOVE AND RESET GUARDRAIL
 N 425+50 TO N 426+77.5 RT

REMOVAL AND DISPOSAL OF GUARDRAIL
 N 426+77.5 TO N 426+85.5 RT

DELINEATOR WITH STEEL POST
 N 426+77.5 RT

SPECIAL PROVISION (STEEL BEAM
 GUARDRAIL GALVANIZED) (8 FEET RADIUS)
 N 426+77.5 RT

MILLED RUMBLE STRIPS
 N 425+50 TO N 431+50 CL

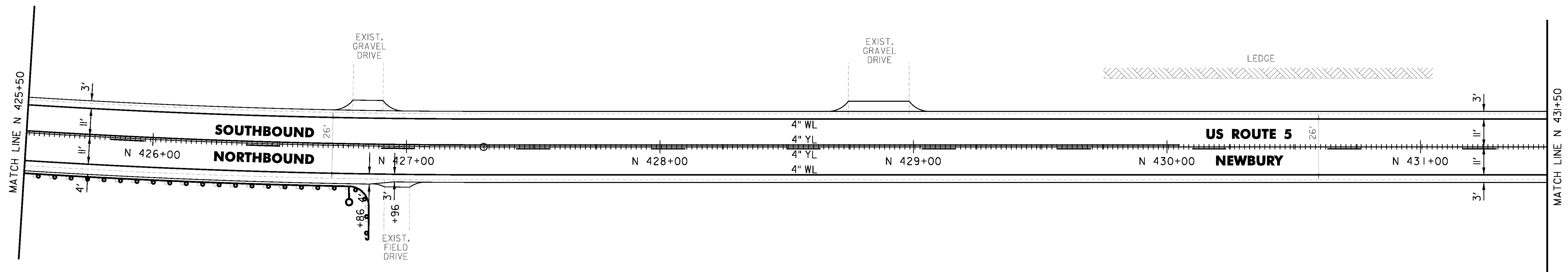

NOT TO SCALE

PROJECT NAME: BRADFORD-RYEGATE	PLOT DATE: 2/4/2016
PROJECT NUMBER: STP 2929(I)	DRAWN BY: W. GORDON
FILE NAME: z10c264bdr.dgn	CHECKED BY: P. SHEDD
PROJECT LEADER: P. SHEDD	SHEET 170 OF 239
DESIGNED BY: N. LEMAY	
US 5 PLAN SHEET 112	