

TEMPORARY 4 INCH WHITE LINE, PAINT  
DURABLE 4 INCH WHITE LINE (OPTION ITEM)  
N 98+50 TO N 104+50 LT & RT

TEMPORARY 4 INCH YELLOW LINE, PAINT  
DURABLE 4 INCH YELLOW LINE (OPTION ITEM)  
N 98+50 TO N 100+30 SOLID LT, DASHED RT  
N 100+30 TO N 100+85 SOLID LT & RT  
N 100+85 TO N 104+50 DASHED LT, SOLID RT

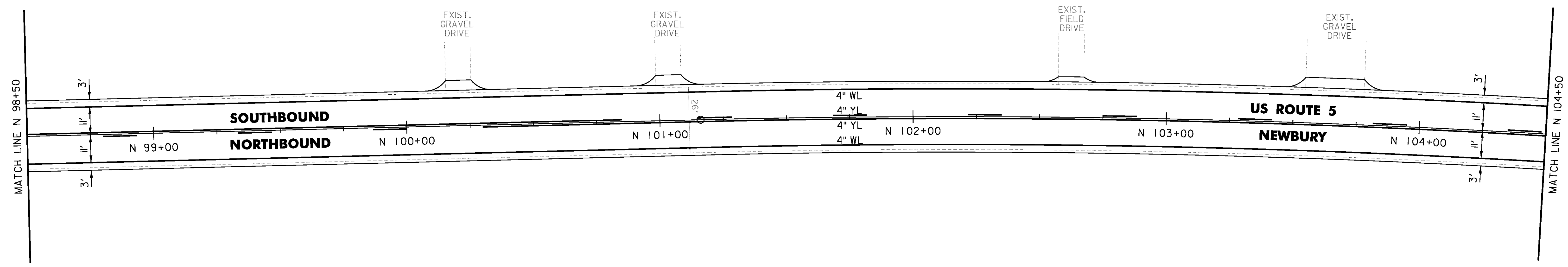

CLD 14-0278

NOT TO SCALE

PROJECT NAME: BRADFORD-RYEGATE	PLOT DATE: 2/4/2016
PROJECT NUMBER: STP 2929(I)	DRAWN BY: W. GORDON
FILE NAME: z10c264bdr.dgn	CHECKED BY: P. SHEDD
PROJECT LEADER: P. SHEDD	SHEET 114 OF 239
DESIGNED BY: N. LEMAY	
US 5 PLAN SHEET 56	