

TEMPORARY 4 INCH WHITE LINE, PAINT  
 DURABLE 4 INCH WHITE LINE (OPTION ITEM)  
 228+50 TO 234+50 SOLID LT & RT

TEMPORARY 4 INCH YELLOW LINE, PAINT  
 DURABLE 4 INCH YELLOW LINE, EPOXY PAINT OR  
 DURABLE 4 INCH YELLOW LINE, POLYUREA (OPTION ITEM)  
 228+50 TO 231+00 SOLID LT & RT  
 231+00 TO 234+50 SOLID LT, DASHED RT

STEEL BEAM GUARDRAIL, GALVANIZED  
 232+19.5 TO 232+57 RT  
 233+07 TO 233+44.5 RT

ANCHOR FOR STEEL BEAM RAIL  
 2 (SEE STANDARD G-1d)  
 REMOVAL AND DISPOSAL OF GUARDRAIL  
 232+19.5 TO 232+57 RT  
 233+07 TO 233+44.5 RT

DELINEATOR WITH STEEL POST  
 232+57 RT  
 233+07 RT

REMOVE AND RESET GUARDRAIL  
 228+50 TO 232+19.5 RT  
 233+44.5 TO 234+50 RT

MILLED RUMBLE STRIPS  
 228+50 TO 234+50 CL

REMOVING SIGNS  
 AS SHOWN - 1

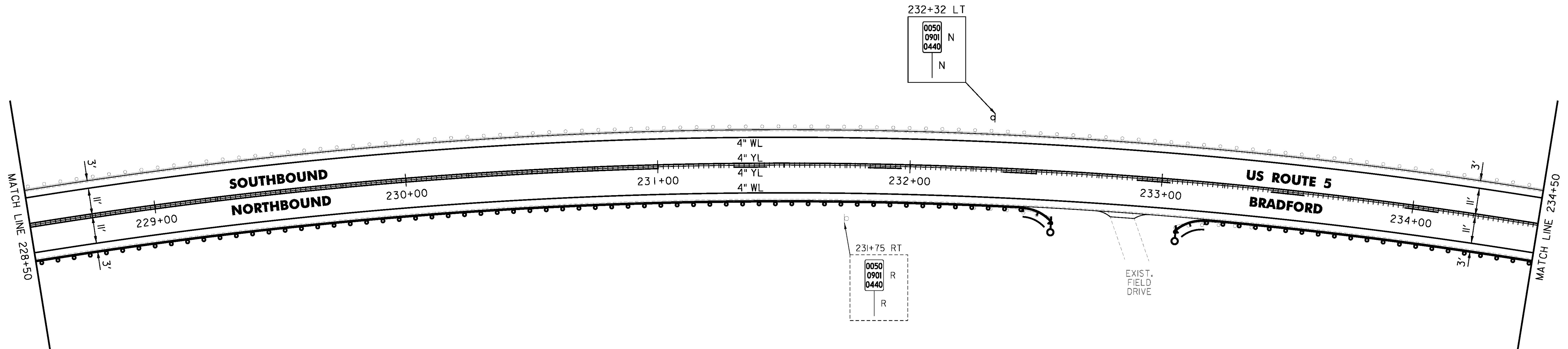

NOT TO SCALE

PROJECT NAME: BRADFORD-RYEGATE	PLOT DATE: 2/4/2016
PROJECT NUMBER: STP 2929(I)	DRAWN BY: W. GORDON
FILE NAME: z10c264bdr.dgn	CHECKED BY: P. SHEDD
PROJECT LEADER: P. SHEDD	SHEET 84 OF 239
DESIGNED BY: N. LEMAY	
US 5 PLAN SHEET 26	