

NOTES:

1. THE COST OF REMOVING THE EXISTING ASPHALT SURFACE AND PAVING THE TWO LIFTS OF TYPE IIS BASE COURSE AT THE RAIL APPROACHES AND BETWEEN THE RAILS SHALL BE PAID FOR UNDER ITEM 490.30 SUPERPAVE BITUMINOUS CONCRETE PAVEMENT. SEE SHEET 16 FOR PAVEMENT QUANTITY BREAKDOWN.
2. THE EXISTING GRADE CROSSING ISLAND CIRCUIT SHALL BE REMOVED AND REPLACED WITH A NEW ACTIVE WARNING SYSTEM. ALL COST ASSOCIATED WITH THE REMOVAL AND INSTALLATION OF THE NEW GRADE CROSSING ACTIVE WARNING SYSTEM SHALL BE PAID FOR UNDER ITEM 900.645 SPECIAL PROVISION (RAIL-HIGHWAY CROSSING ACTIVE WARNING SYSTEM) (AARDOT 248-907C) AS DIRECTED BY THE RESIDENT ENGINEER. SEE SHEET 89 FOR AARDOT 248-907C GRADE CROSSING SIGNAL SHEET.
3. THE CONTRACTOR SHALL INSTALL THE ELASTOMERIC INTERFACE RAIL SEAL CONNECTED BY AN INTERCLAMP DEVICE IN ACCORDANCE WITH THE MANUFACTURER'S RECOMMENDATIONS. THESE DETAILS DO NOT ILLUSTRATE THE INTERCLAMP DEVICES. NO VEHICULAR TRAFFIC IS ALLOWED OVER THE RAIL SEAL UNTIL FULL DEPTH PAVEMENT IS PLACED ON BOTH SIDES OF THE RAIL. ANY DAMAGE TO THE NEW ELASTOMERIC INTERFACE RESULTING FROM THE CONTRACTOR'S INSTALLATION METHODS SHALL BE REPLACED AT THE CONTRACTOR'S OWN EXPENSE AS DIRECTED BY THE RESIDENT ENGINEER. THE COST OF FURNISHING AND INSTALLING THE ELASTOMERIC INTERFACE AND ATTACHMENT HARDWARE SHALL BE INCLUDED IN THE UNIT BID PRICE FOR ITEM 900.640 SPECIAL PROVISION (RUBBER RAIL SEAL).
4. TEN DAYS PRIOR TO BEGINNING WORK ON THIS RAIL CROSSING THE CONTRACTOR SHALL COORDINATE CONSTRUCTION ACTIVITIES WITH CLARENDON AND PITTSFORD RAILROAD. THE CONTRACTOR IS RESPONSIBLE TO HAVE THE TRACK AND ALL ACTIVE WARNING DEVICES BACK IN SERVICE AT THE END OF EACH WORK DAY. THE COST FOR COORDINATION WITH CLARENDON AND PITTSFORD RAILROAD SHALL BE INCIDENTAL TO ITEM 900.645 SPECIAL PROVISION (MAINTENANCE OF RAILROAD TRAFFIC) (N.A.B.I.).

THE CONTRACTOR SHALL COMPLETE ALL WORK ASSOCIATED WITH THIS CROSSING WITHIN FIVE CONTINUOUS WORKING DAYS. THE CONTRACTOR IS HEREBY NOTIFIED THAT LIQUIDATED DAMAGES IN ACCORDANCE WITH THE RAILROAD SPECIAL PROVISIONS WILL BE ASSESSED FOR EVERY CALENDAR DAY FOLLOWING THE FIVE CONSECUTIVE WORKDAY PERIOD THAT THE SPECIFIED WORK IS NOT COMPLETED.

5. TIE PLATES SHALL BE MINIMUM 14" L x 7 3/4" W NEW OR FIT DOUBLE SHOULDERED TO FIT THE BASE OF THE RAIL ON WHICH THEY WILL BE USED. EACH TIE PLATE SHALL HAVE AT LEAST 6 HOLES PUNCHED FOR THE USE OF 3/8" TRACK SPIKES. FOUR OF THE HOLES SHALL BE SUCH THAT THEY ALLOW TWO RAIL HOLDING SPIKES ON EACH SIDE OF THE RAIL AND THERE SHALL ALSO BE AT LEAST TWO HOLES FOR PLATE HOLDING SPIKES. THE CONTRACTOR SHALL FURNISH AND INSTALL ALL TIE PLATES, SPIKES AND RAIL ANCHORS UNDER APPROPRIATE CROSS TIE ITEM 900.620 SPECIAL PROVISION (REMOVAL AND REPLACEMENT OF CROSS TIES).
6. THE CONTRACTOR SHALL PROVIDE NEW 136 RE CWR AS SPECIFIED IN THE PLANS. RAIL WEIGHTS SHALL BE VERIFIED BY THE RAILROAD AND APPROVED BY THE RESIDENT ENGINEER.
7. THE COST FOR PROVIDING VEHICULAR TRAFFIC CONTROL DURING CONSTRUCTION OF THIS PAVED RAIL HIGHWAY CROSSING SHALL BE CONSIDERED INCIDENTAL TO ITEM 641.10 TRAFFIC CONTROL (STP 2705(i)).
8. UNCLASSIFIED EXCAVATION SHALL CONSIST OF THE EXCAVATION AND DISPOSAL FROM THE WORK SITE ALL MATERIALS OF ANY DESCRIPTION ENCOUNTERED IN THE COURSE OF CONSTRUCTION, AND SHALL BE PAID FOR UNDER ITEM 203.17 UNCLASSIFIED EXCAVATION.
9. THE CONTRACTOR SHALL INSTALL GEOTEXTILE UNDER THE RAILROAD BALLAST WITHIN THE LIMITS OF THE CROSSING PER SECTION 649 OF THE 2006 VTRANS STANDARD SPECIFICATIONS FOR CONSTRUCTION OR AS DIRECTED BY THE RESIDENT ENGINEER. PAYMENT WILL BE MADE UNDER ITEM 649.21 GEOTEXTILE UNDER RAILROAD BALLAST.

10. BALLAST MATERIAL SUPPLIED MUST BE APPROVED BY THE CLARENDON AND PITTSFORD RAILROAD PRIOR TO ITS ACCEPTANCE. BALLAST SURFACING AND BALLAST BASE COURSE TO BE PAID FOR UNDER ITEM 900.680 SPECIAL PROVISION (RAILROAD BALLAST). THE OWNER (CLP) AND THE RESIDENT ENGINEER RESERVE THE RIGHT TO SAMPLE AND TEST THE STONE BALLAST UP TO AND INCLUDING THE POINT OF USE.

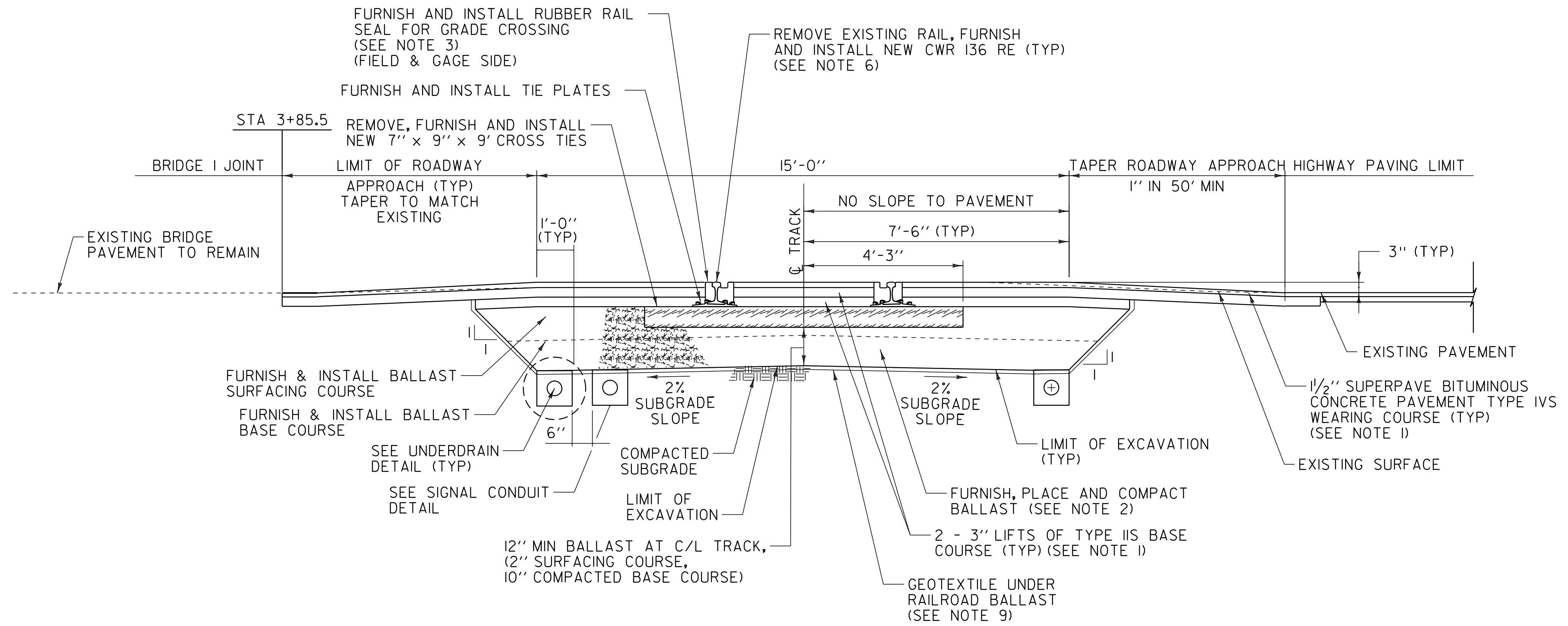

TYPICAL SECTION - ASPHALT GRADE CROSSING

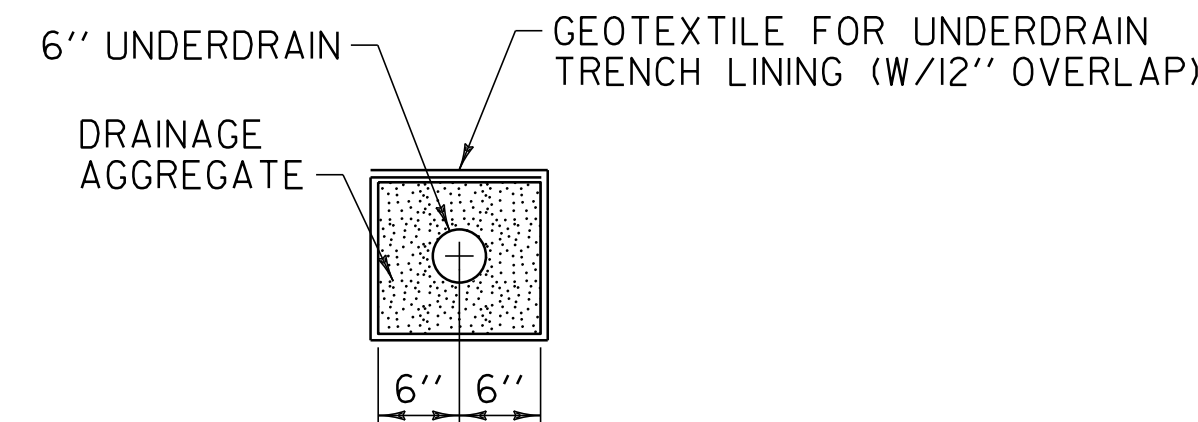

UNDERDRAIN WITH GEOTEXTILE

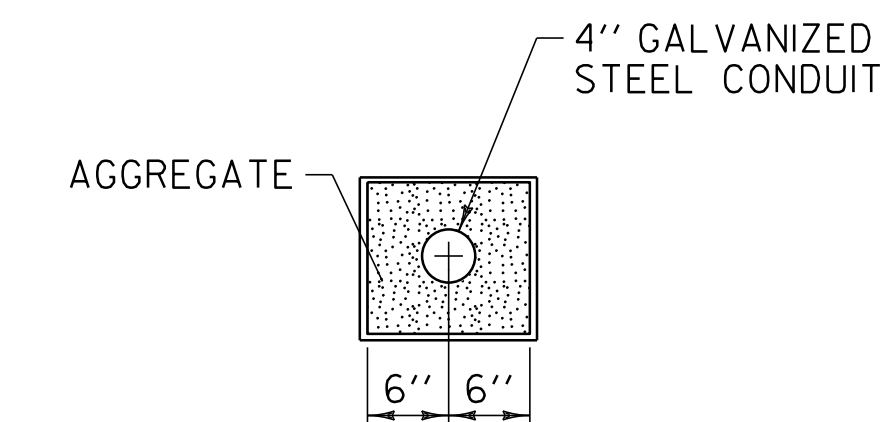

SIGNAL CONDUIT DETAIL

AARDOT 248-907C GRADE CROSSING QUANTITIES			
ITEM	DESCRIPTION	UNIT	QTY
203.17	UNCLASSIFIED EXCAVATION	CY	80
204.20	TRENCH EXCAVATION OF EARTH	CY	30
490.30	SUPERPAVE BITUMINOUS CONCRETE PAVEMENT	TON	95
605.10	6 INCH UNDERDRAIN PIPE	LF	300
649.21	GEOTEXTILE UNDER RAILROAD BALLAST	SY	85
900.620	SPECIAL PROVISION (REMOVAL AND REPLACEMENT OF CROSS TIES)	EA	157
900.620	SPECIAL PROVISION (THERMITE WELDING)	EA	4
900.640	SPECIAL PROVISION (CONTINUOUS WELDED RAIL)	LF	360
900.640	SPECIAL PROVISION (RESURFACE TRACK APPROACHES) *	LF	400
900.640	SPECIAL PROVISION (RUBBER RAIL SEAL)	LF	100
900.645	SPECIAL PROVISION (RAIL-HIGHWAY CROSSING ACTIVE WARNING SYSTEM) (AARDOT 248-907C)	LS	1
900.650	SPECIAL PROVISION (MAINTENANCE OF RAILROAD TRAFFIC) (N.A.B.I.)	LU	1
900.680	SPECIAL PROVISION (RAILROAD BALLAST)	TON	150

RESURFACING SHALL BE MEASURED IN TRACK FEET & SHALL BE TO FINAL GRADE
*

NOT TO SCALE

AARDOT 248-907C GRADE CROSSING DETAIL SHEET	PROJECT NAME: CASTLETON - WEST RUTLAND	PLOT DATE: 04-JUN-2013 09:14
	PROJECT NUMBER: STP 2705(i)	DRAWN BY: W.G.P.
	FILE NAME: p07cl68.dgn	CHECKED BY: D.E.G.
	DESIGNED BY: M.J.M.	SHEET 88 OF 152