

613.10 STONE FILL, TYPE I
STA 119+10 TO 123+50 LT

DURABLE 4 INCH WHITE LINE (SEE OPTION AA)
DURABLE 4 INCH YELLOW LINE (SEE OPTION BB)
STA 118+00 TO 123+50 RT & LT

646.602 TEMPORARY 4 INCH WHITE LINE, PAINT
646.612 TEMPORARY 4 INCH YELLOW LINE, PAINT
STA 118+00 TO 123+50 RT & LT

649.31 GEOTEXTILE UNDER STONE FILL
STA 119+10 TO 123+50 LT

675.20 TRAFFIC SIGN, TYPE A
STA 118+14 RT
STA 120+11 LT (2)

675.341 SQUARE TUBE SIGN POST AND ANCHOR
STA 118+14 RT
STA 120+11 LT

675.50 REMOVING SIGNS
STA 118+14 RT
STA 120+11 LT (2)
STA 122+20 RT

900.675 SPECIAL PROVISION
(HAND-PLACED BITUMINOUS CONCRETE MATERIAL, DRIVES)
STA 118+98 LT
STA 119+65 RT
STA 122+03 RT

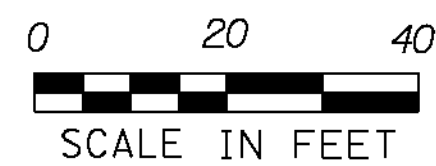
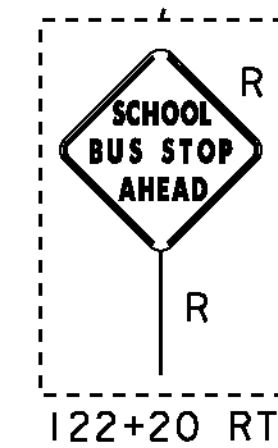
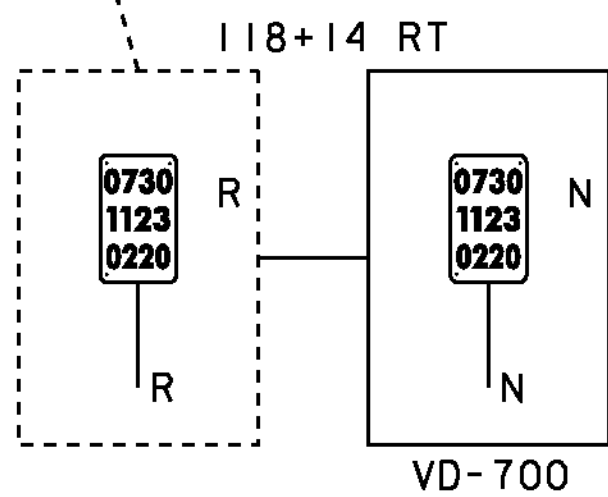
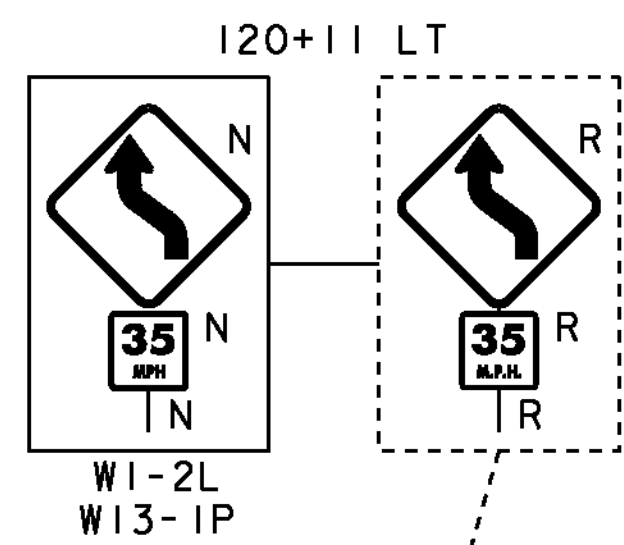
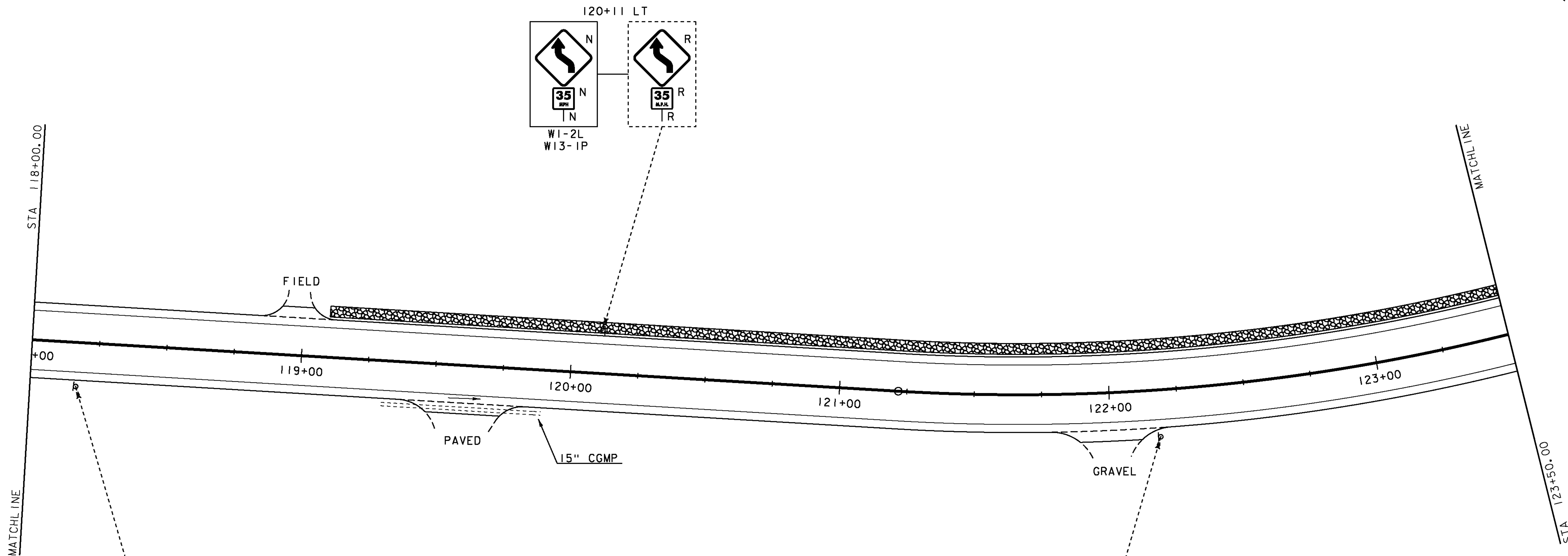
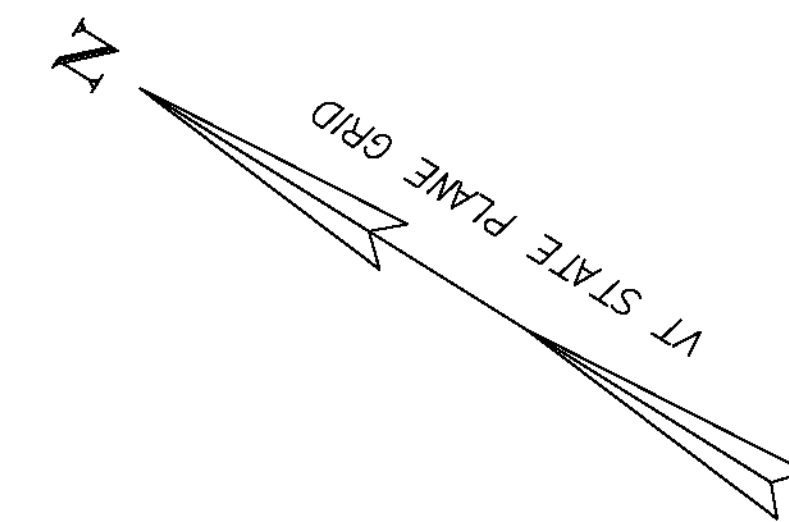

SIGN LEGEND

R	= REMOVE
S	= SALVAGE
N	= NEW
RET	= RETAIN
T&T	= THINNING & TRIMMING
B-B	= BACK TO BACK
EXISTING	-----
NEW	-----

PROJECT NAME:	SUDBURY - BRANDON	FILE NAME:	d:\0c204_bdr.dgn	PLOT DATE:	13-FEB-2013
PROJECT NUMBER:	STP 0158(3)	DESIGNED BY:	B. MCADAMS	DRAWN BY:	B. MCADAMS
		CHECKED BY:	A. KEMPTON		
		LAYOUT 19			SHEET 37 OF 137