

* RAIL POST DIMENSIONED TO C OF BRIDGE POST HAS BEEN PROVIDED FOR INFORMATIONAL PURPOSES ONLY. ACTUAL LOCATION SHALL BE DETERMINED BY THE FABRICATOR.

NOTE: REINFORCING NOT SHOWN FOR CLARITY.

ABUTMENT NO. 1 CLOSURE POUR PLAN

SCALE: $\frac{3}{8}'' = 1'-0''$

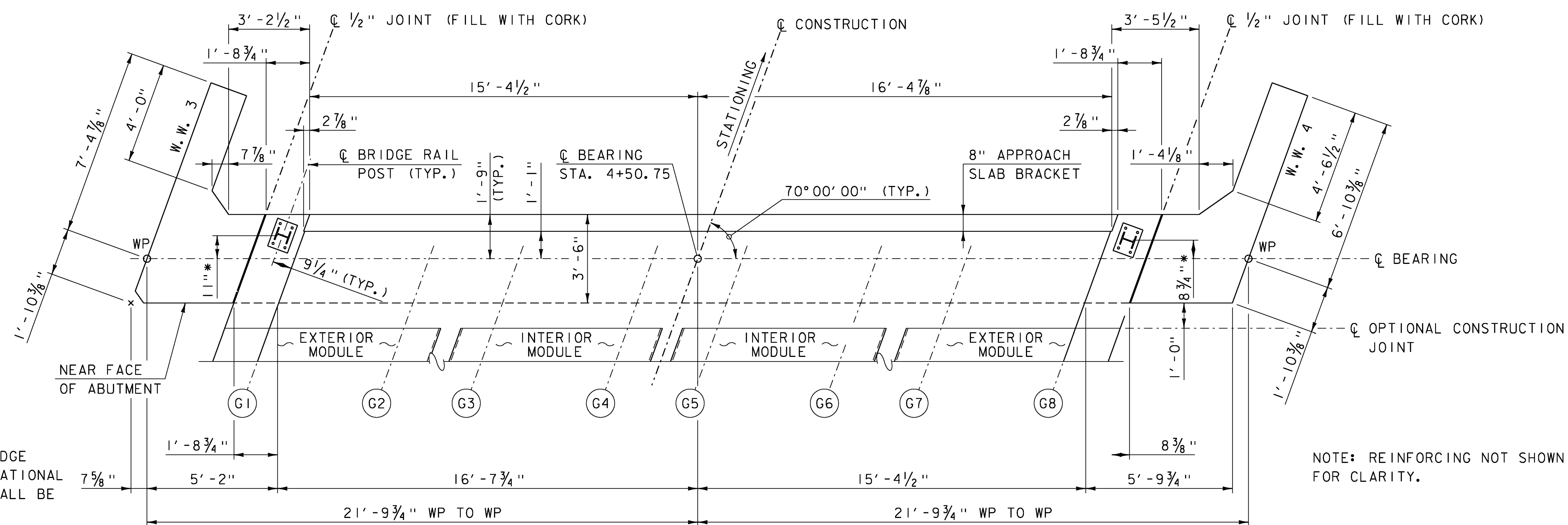
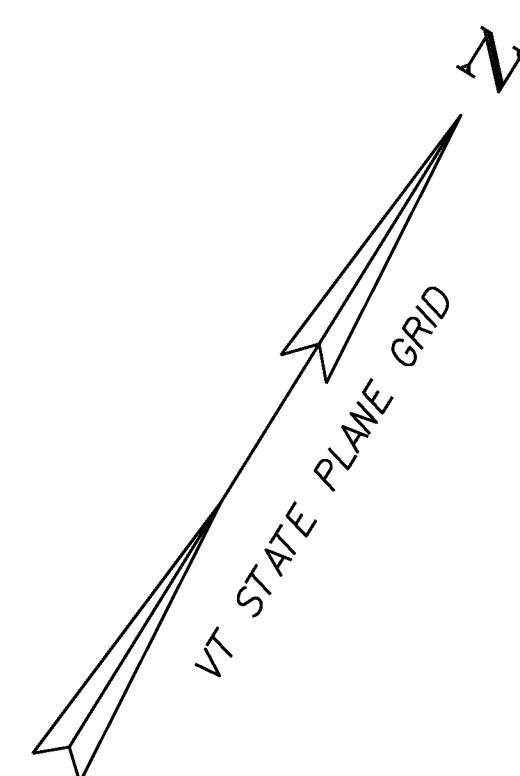

* RAIL POST DIMENSIONED TO C OF BRIDGE POST HAS BEEN PROVIDED FOR INFORMATIONAL PURPOSES ONLY. ACTUAL LOCATION SHALL BE DETERMINED BY THE FABRICATOR.

NOTE: REINFORCING NOT SHOWN FOR CLARITY.

ABUTMENT NO. 2 CLOSURE POUR PLAN

SCALE: $\frac{3}{8}'' = 1'-0''$

PROJECT NAME: WARREN
PROJECT NUMBER: BRF 013-4(32)

FILE NAME: z10b424abu+dtis.dgn PLOT DATE: 03-OCT-2013
PROJECT LEADER: R. YOUNG DRAWN BY: S. MERKWAN
DESIGNED BY: D. KULL CHECKED BY: T. KENDRICK
ABUTMENT CLOSURE POUR DETAILS SHEET 27 OF 42

