

TEMPORARY 4 INCH WHITE LINE, PAINT  
 DURABLE 4 INCH WHITE LINE  
 29+50 TO 34+50 SOLID LT & RT

TEMPORARY 4 INCH YELLOW LINE, PAINT  
 DURABLE 4 INCH YELLOW LINE  
 29+50 TO 30+92 DOUBLE SOLID LT  
 29+50 TO 34+50 SOLID LT & RT

DURABLE 8 INCH YELLOW LINE  
 29+50 TO 30+14 LT (DIAGONALS)

TEMPORARY LETTER OR SYMBOL, PAINT  
 DURABLE LETTER OR SYMBOL  
 33+79 LT - "AHEAD"  
 34+19 LT - "SIGNAL"

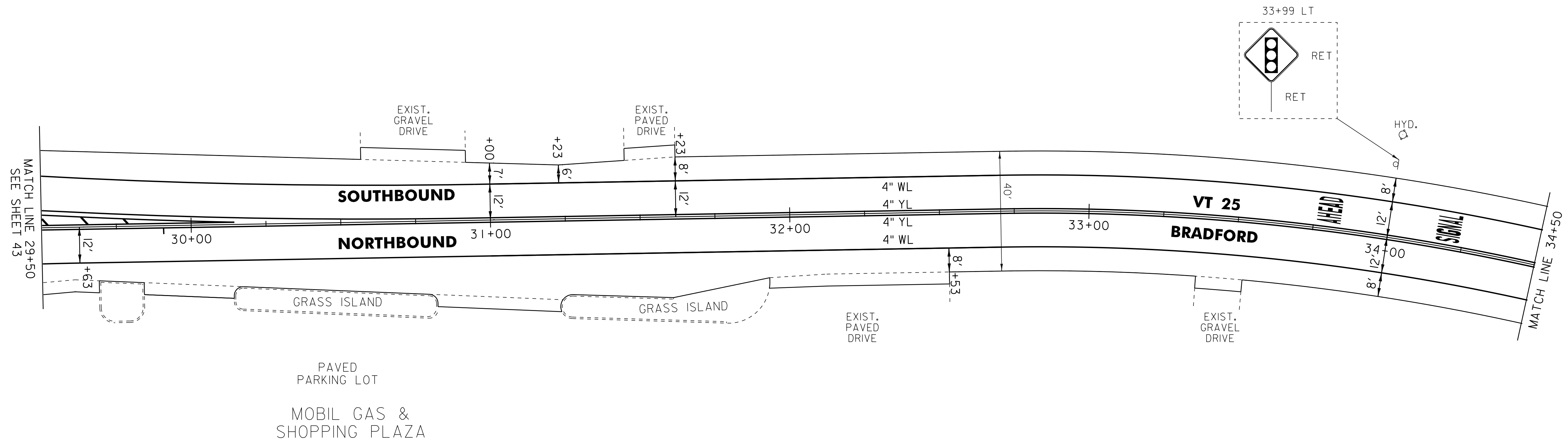

**LEGEND**

- R = REMOVE EXISTING
- S = SALVAGED
- R&S = REMOVE AND SALVAGE
- N = NEW
- RET = RETAIN
- B-B = BACK TO BACK
- = EXISTING GUARDRAIL
- = PROPOSED GUARDRAIL
- YL = YELLOW LINE
- WL = WHITE LINE
- = DELINEATOR
- ||||| = RUMBLE STRIP

**ROADWAY LAYOUT 5 VT 25**

PROJECT NAME: BRADFORD

PROJECT NUMBER: STP 2917(1)

FILE NAME: p10b236.dgn

PROJECT LEADER: PTS

DESIGNED BY: NULL

IPARM FILE NAME: p10b236\_46

PLOT DATE: 03-SEP-2014 12:50

DRAWN BY: SNG

CHECKED BY: PTS

SHEET 46 OF 105

NOT TO SCALE