

DURABLE 4 INCH WHITE LINE, TYPE I TAPE
 STA. 50+75 - STA. 56+25 (SOLID LT & RT)

DURABLE 4 INCH YELLOW LINE, TYPE I TAPE
 STA. 50+75 - STA. 53+43 (CENTERLINE LT)
 STA. 50+75 - STA. 53+43 (CENTERLINE RT)
 STA. 50+75 - STA. 52+43 (SOLID LT)
 STA. 50+75 - STA. 52+43 (DASHED LT)
 STA. 53+83 - STA. 56+25 (CENTERLINE LT)
 STA. 53+83 - STA. 54+83 (CENTERLINE RT)

DURABLE 8 INCH YELLOW LINE, TYPE I TAPE
 STA. 50+75 - STA. 53+43 (HATCHED LT)
 STA. 53+83 - STA. 54+83 (HATCHED LT)

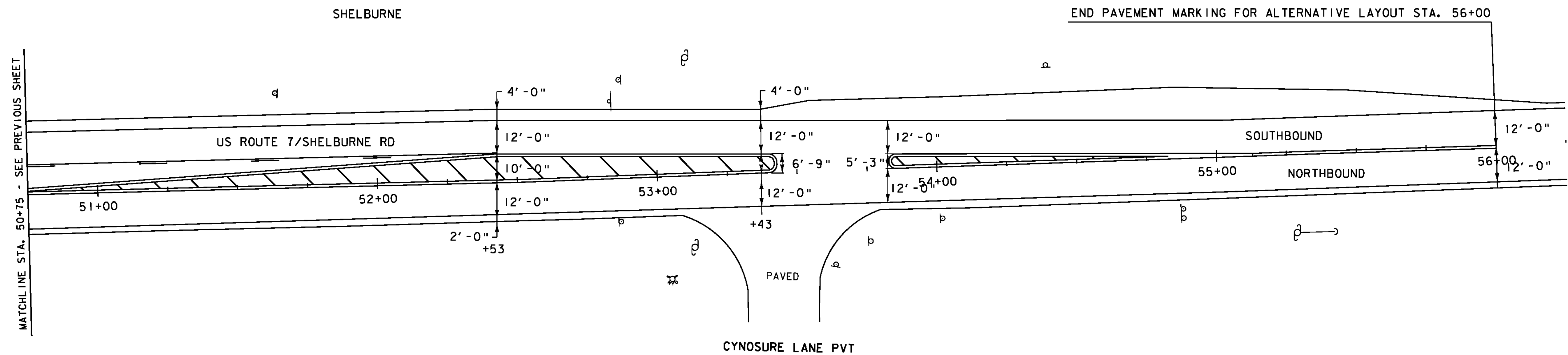
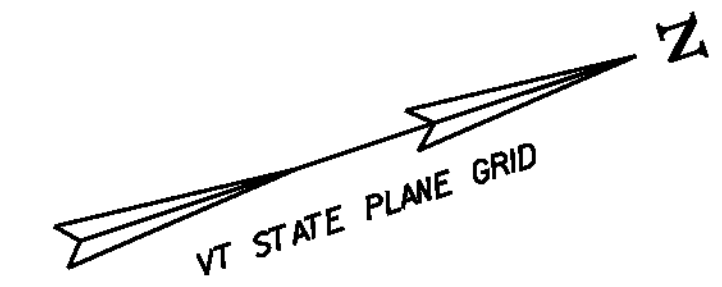

- LEGEND**
- | | | | |
|---|--------------------------|---|-------------------------|
| ○ | SIGN | ● | LIGHT POLE |
| ○ | HYDRANT | ■ | EX. DETECTABLE WARNINGS |
| ○ | MANHOLE | □ | JUNCTION BOX |
| ○ | VALVE | ⊞ | PED BUTTON |
| ○ | GAS PIPELINE MARKER | □ | ELECTRICAL BOX |
| □ | CATCH BASIN / DROP INLET | ⊞ | SIGNAL |
| □ | CURB INLET | ⊞ | PEDESTAL POST |
| ⊞ | TRAFFIC CONTROL BOX | ⊞ | STRAIN POLE |
| ⊞ | PARKING METER | → | CAMERA |
| ⊞ | UTILITY POLE | → | VIDEO DETECTION ZONE |
- SIGN LEGEND**
- | | |
|-----|----------------------|
| R | = REMOVE |
| R&S | = REMOVE AND SALVAGE |
| RET | = RETAIN |
| S | = SALVAGE |
| N | = NEW |
| B-B | = BACK TO BACK |

NOT TO SCALE

**ALTERNATIVE
 LAYOUT PLAN
 SHEET 3**

PROJECT NAME: CHARLOTTE-SOUTH BURLINGTON
 PROJECT NUMBER: NH 2907(1)

FILE NAME: p10B206.dgn
 PROJECT LEADER: CDL
 DESIGNED BY: BMB
 PLOT FILE: p10B206_107.1

PLOT DATE: 4/19/12
 DRAWN BY: BMB
 CHECKED BY: EPD
 SHEET 107 OF 107