

XX DENOTES ADVISORY SPEED AS SHOWN ON THE PLANS

W13-1

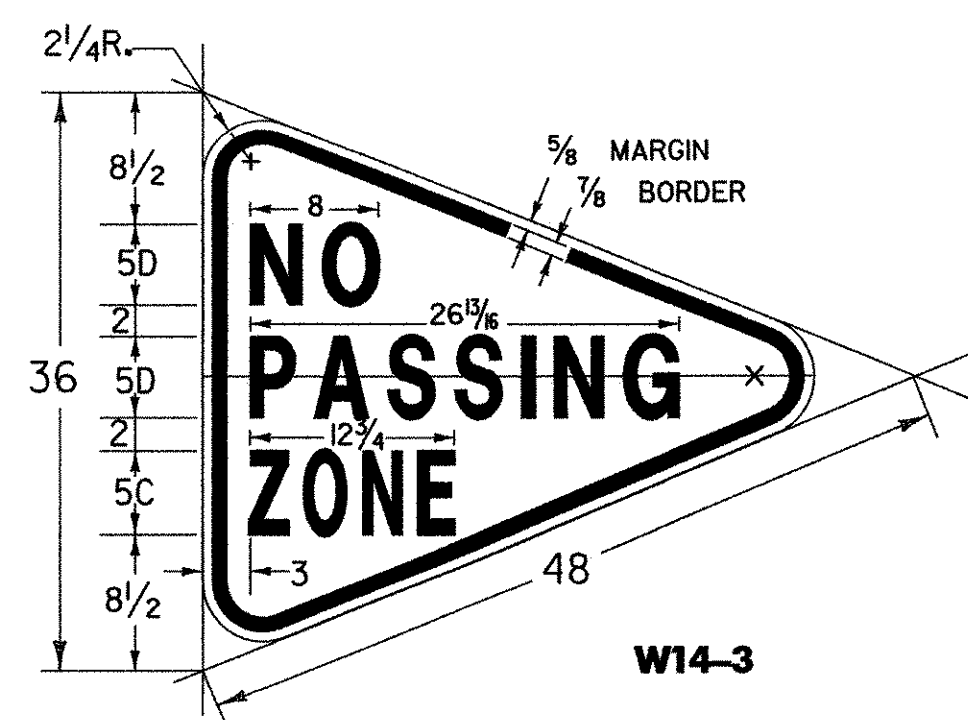

W14-3

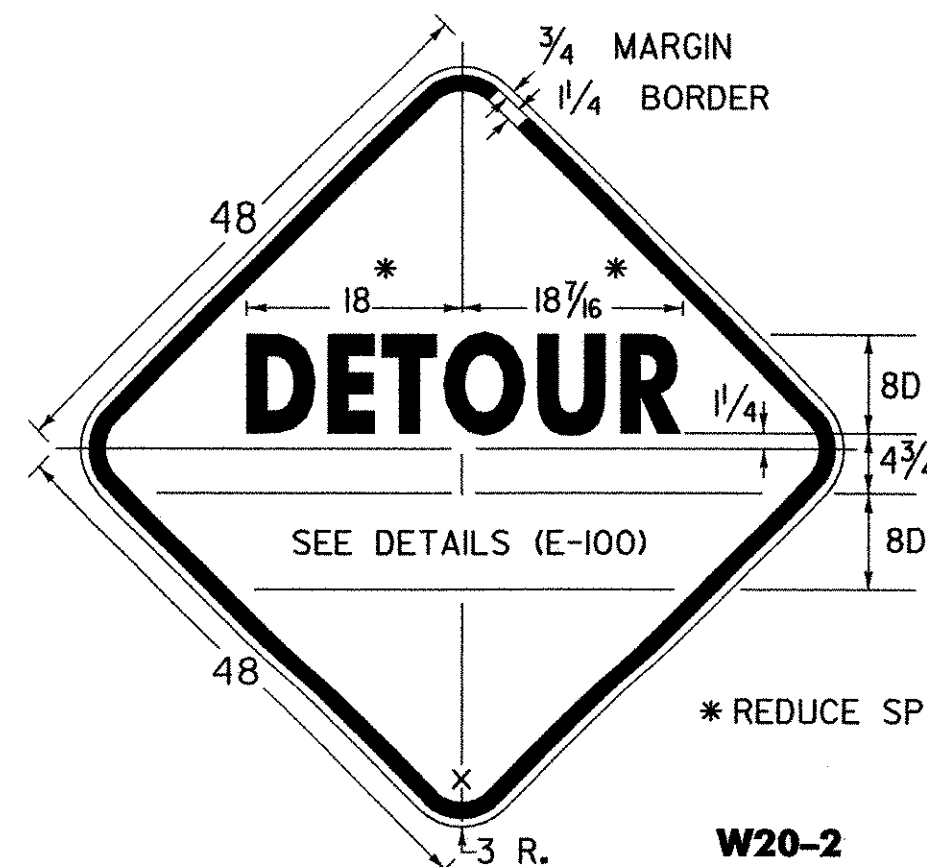

W20-2

* REDUCE SPACING 40%.

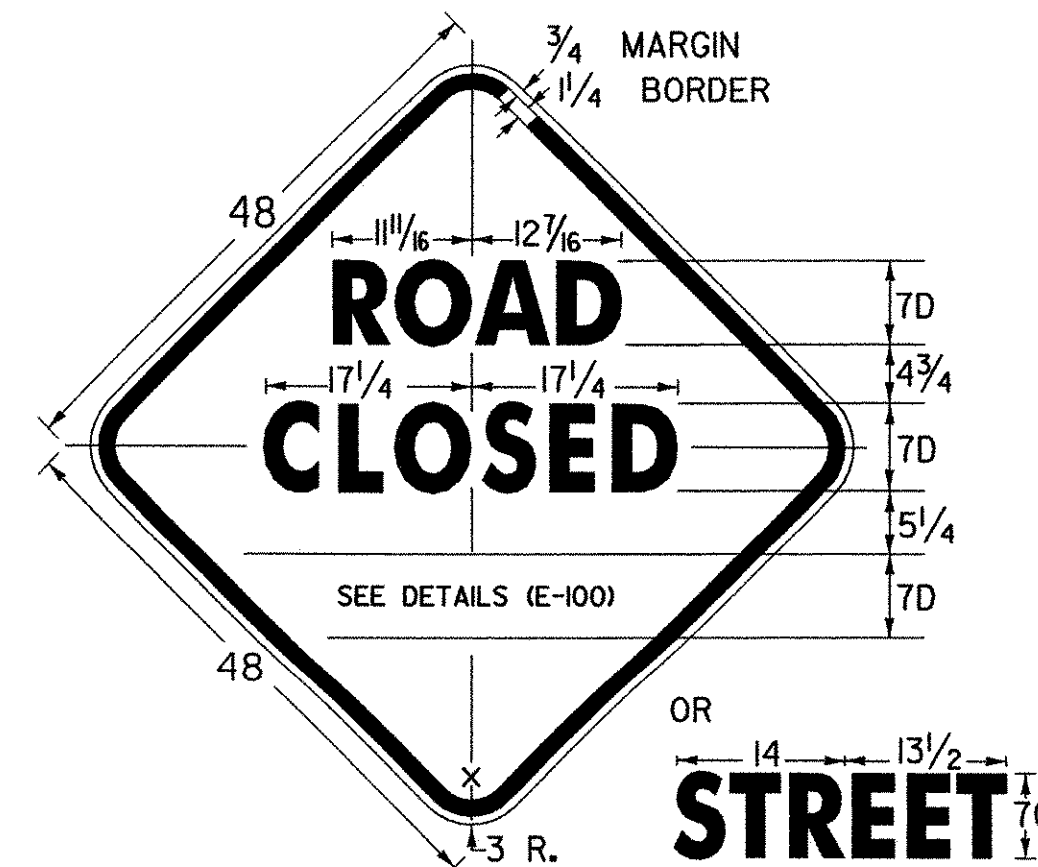

W20-3

OR
STREET

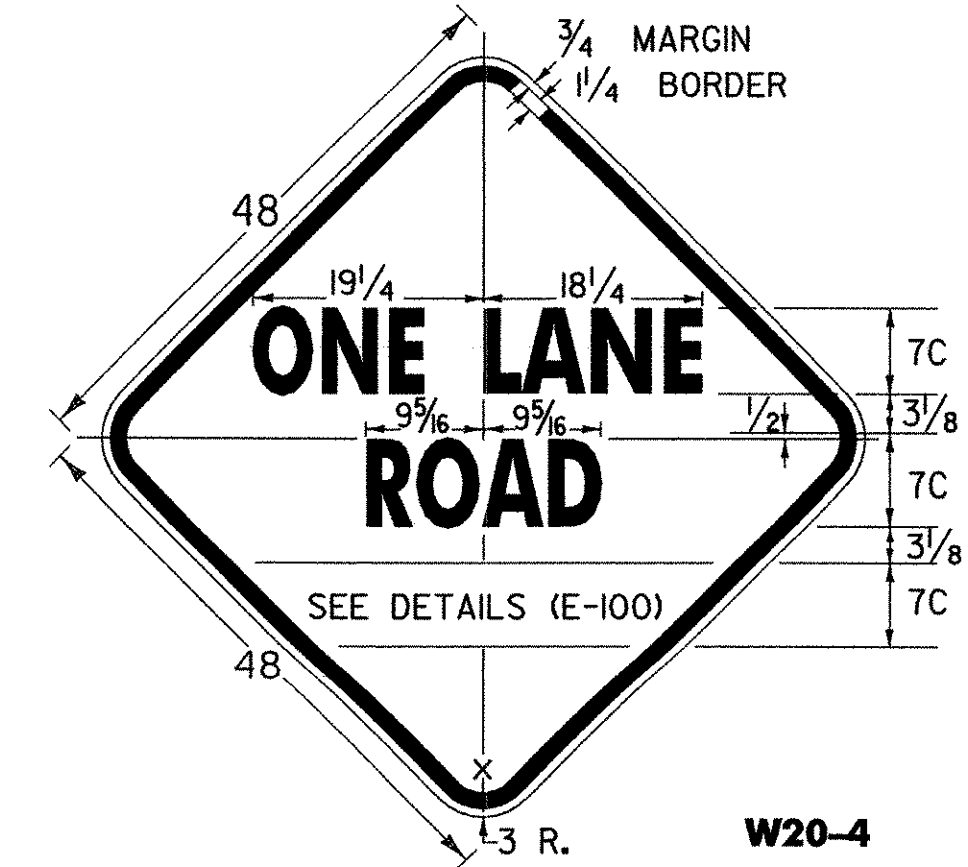

W20-4

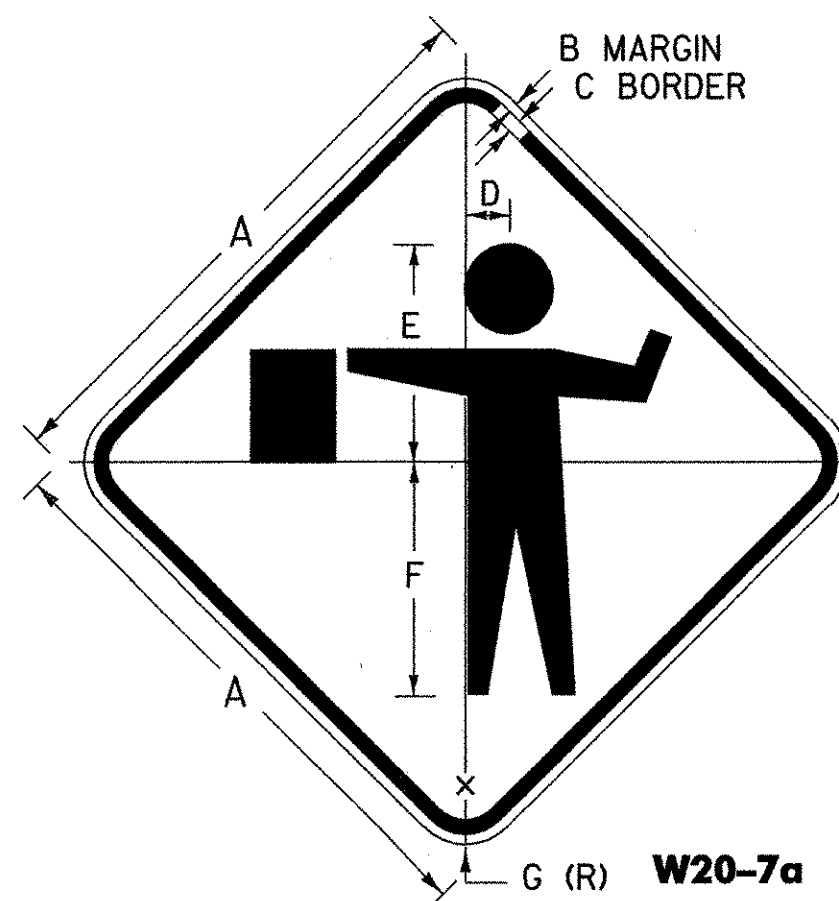

W20-7a



W20-7b

COLORS:
BLACK BORDER AND TEXT (NON RETRORFL.)
ORANGE BACKGROUND (RETRORFL.)

W3-4

COLORS:
BLACK BORDER AND TEXT (NON RETRORFL.)
YELLOW BACKGROUND (RETRORFL.)

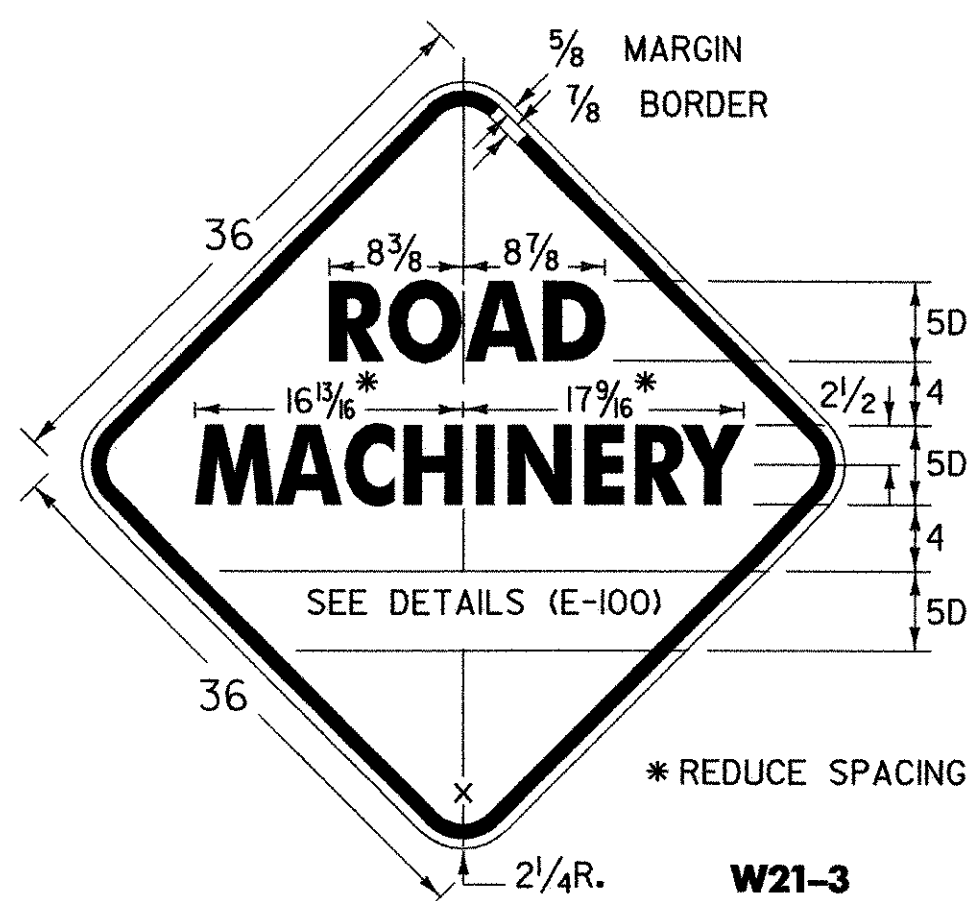

W21-3

* REDUCE SPACING 40%.

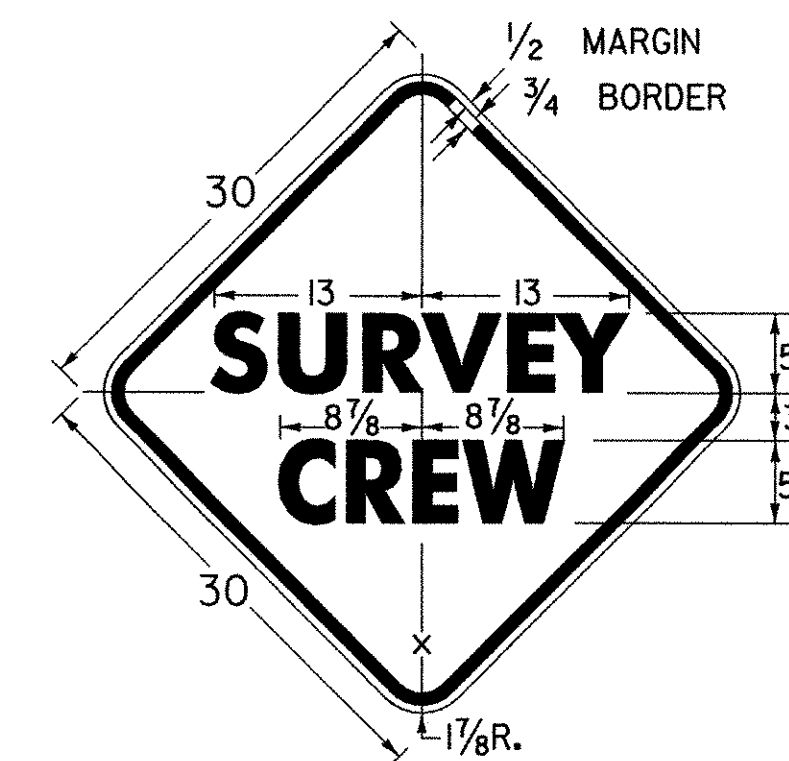

W21-6

SIGN PADDLE FOR FLAGPERSON

ORANGE ASTM TYPE III OR TYPE VI RETROREFLECTORIZED DIAMOND WITH BLACK TEXT AND BORDER

RED ASTM TYPE III OR TYPE VI RETROREFLECTORIZED OCTAGON WITH WHITE ASTM TYPE III OR TYPE VI RETROREFLECTORIZED TEXT

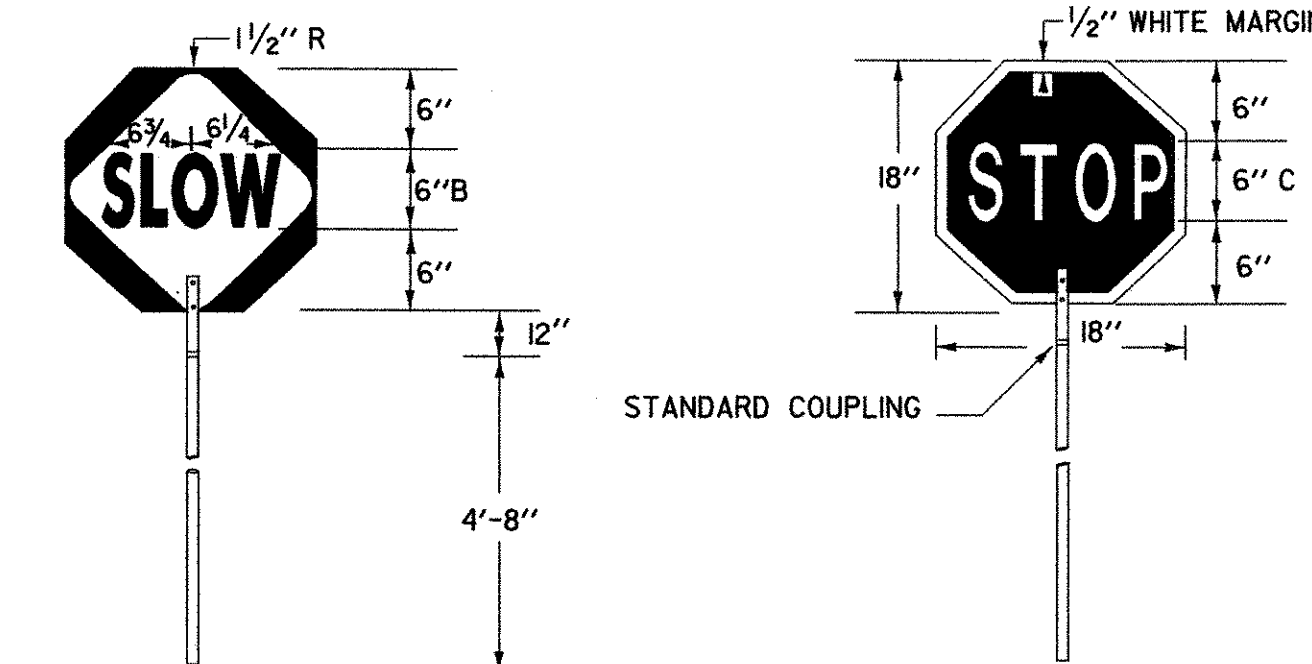

SIGN DETAIL

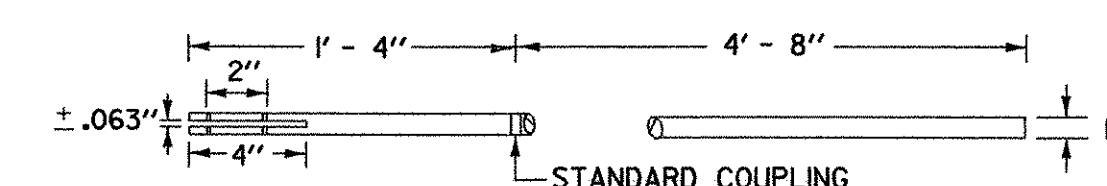

STAFF DETAIL

MATERIALS
THE SIGN MATERIALS SHALL BE 0.063" ALUMINUM WITH COLORS AS INDICATED ON DETAILS.
THE STAFF SHALL BE 1/4" DIAMETER RIGID ALUMINUM CONDUIT/TUBING WITH A WALL THICKNESS OF 0.125", OR 1" TO 1 1/2" DIAMETER RIGID PVC CONDUIT/TUBING WITH 0.125" WALL THICKNESS

MOUNTING
THE STAFF SHALL BE MOUNTED WITH EITHER TWO 1/4" DIAMETER ALUMINUM BOLTS OR TWO 1/4" DIAMETER ALUMINUM RIVETS.

NOTES

SEE STANDARD SHEET E-100 FOR NOTES AND TEXT DETAILS
COLORS FOR SIGNS SHOWN ON THIS SHEET SHALL BE BLACK TEXT, BORDER AND SYMBOLS ON ASTM TYPE III OR TYPE VI RETROREFLECTORIZED ORANGE BACKGROUND, UNLESS OTHERWISE NOTED
SIGN DETAILS INDICATE THE APPROPRIATE COLOR.

SIGN	DIMENSIONS (INCHES)						
	A	B	C	D	E	F	G
STD.	36	5/8	7/8	2 3/4	13 1/2	14 5/8	2 1/4
FWY.	48	3/4	1 1/4	3 3/4	18	19 1/2	3

SIGN	DIMENSIONS (INCHES)											
	A	B	C	D	E	F	G	H	J	K	L	
MIN.	36	5/8	7/8	6C	3 3/8	7/8	3 3/4	16 3/8	13	13 3/8	2 1/4	
STD.	48	3/4	1 1/4	8C	4 7/8	1 1/4	5	21 7/8	17 3/8	18 1/2	3	
EXPWY.	60	3/4	1 1/4	9C	5 3/8	1 3/8	5 5/8	24 9/8	19 3/8	20 1/4	3	

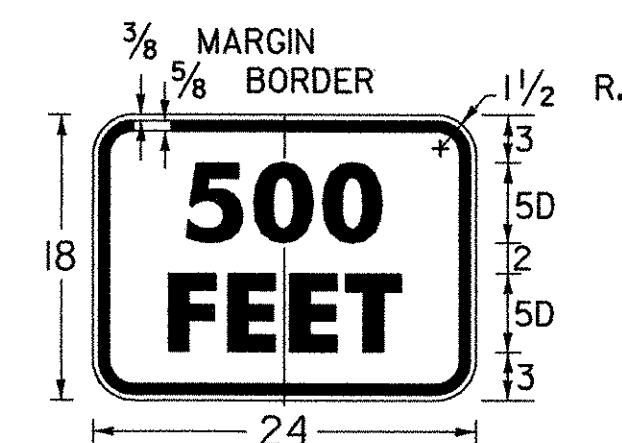
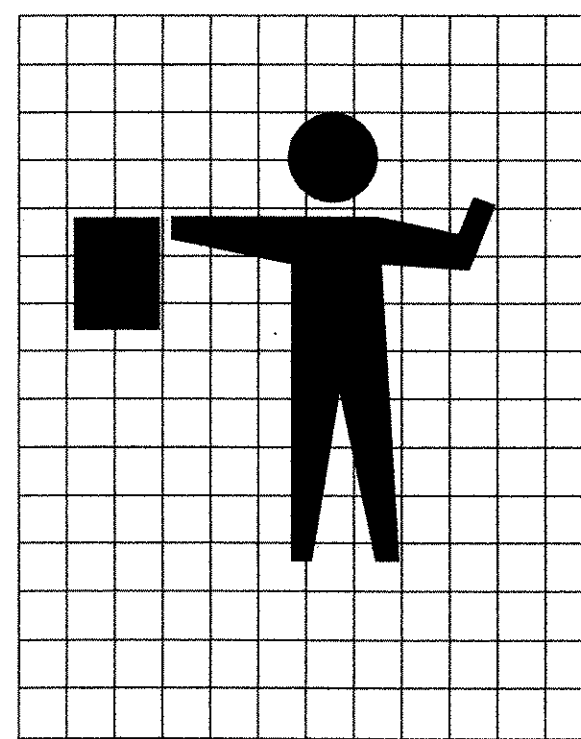

W16-2a

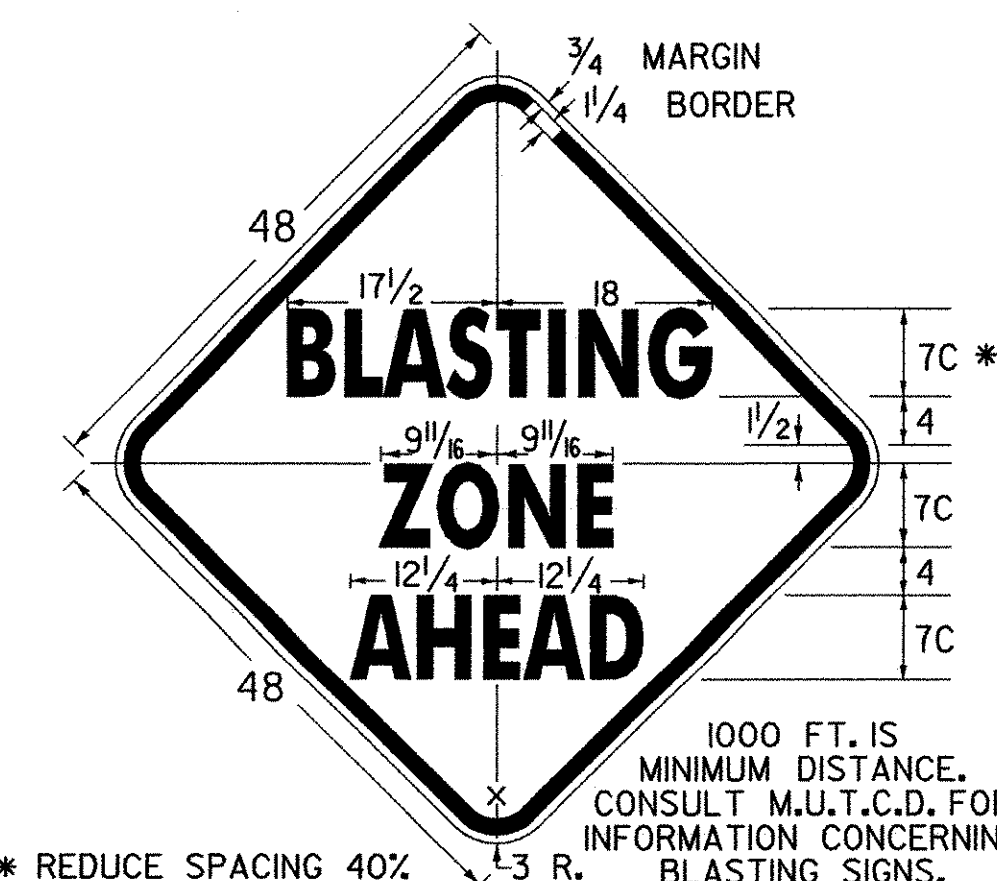

W22-1

1000 FT. IS MINIMUM DISTANCE. CONSULT M.U.T.C.D. FOR INFORMATION CONCERNING BLASTING SIGNS.

* REDUCE SPACING 40%.

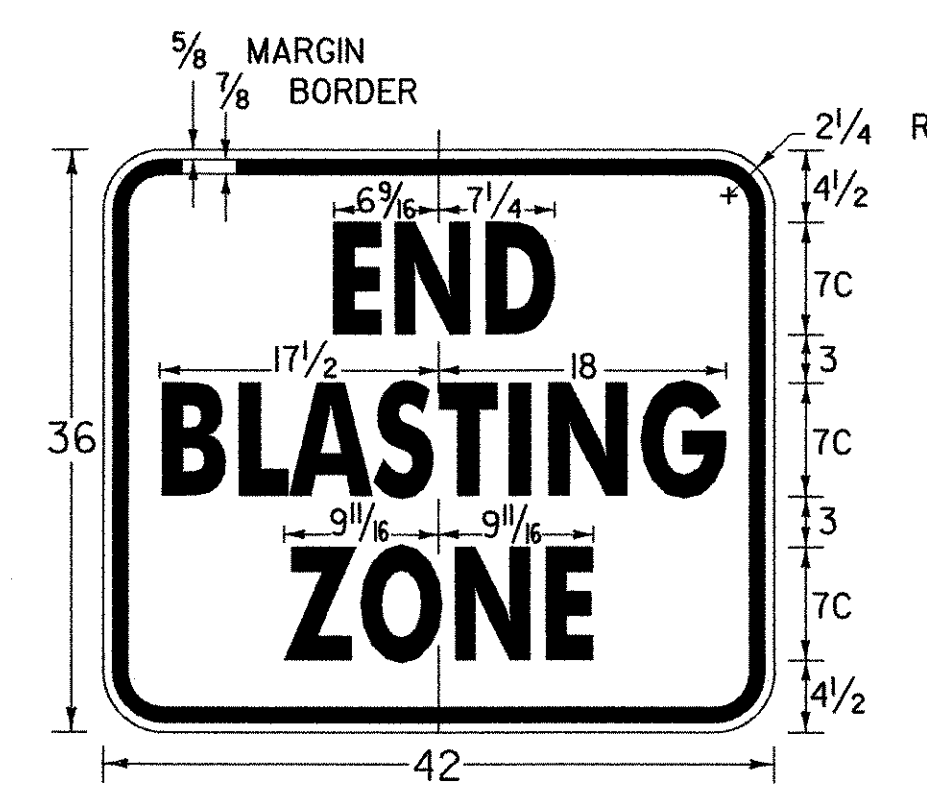

W22-3

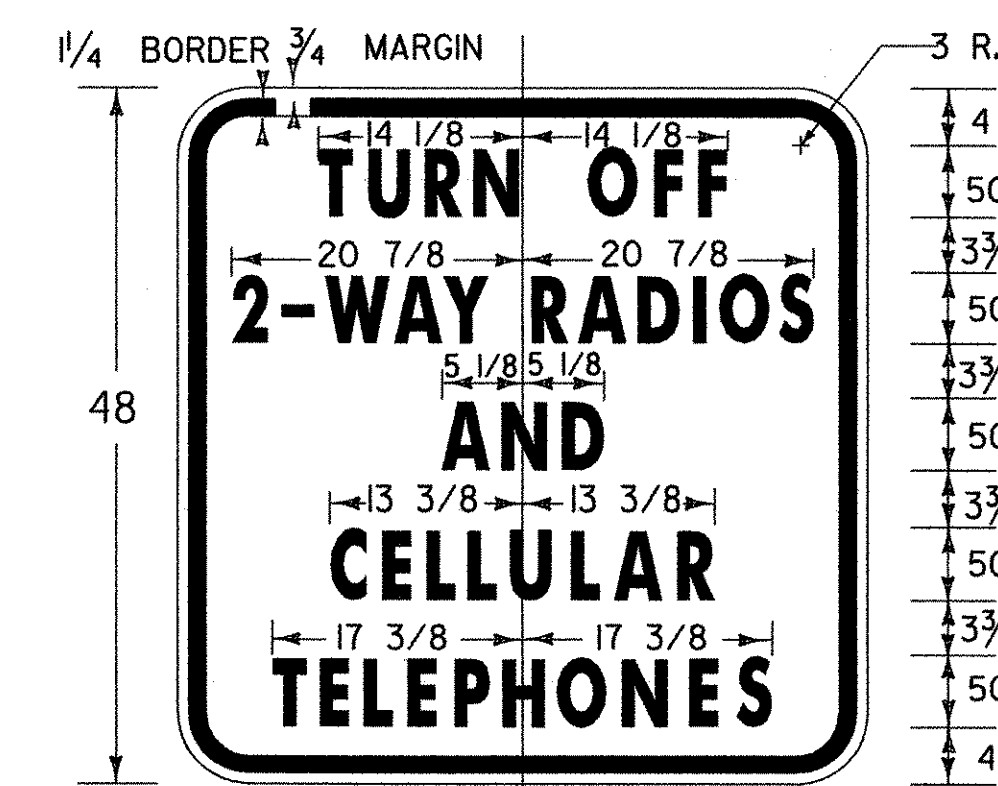

VW22-1

REVISIONS AND CORRECTIONS

- OCT. 30, 1987 - DATE OF ORIGINAL ISSUE
- JAN. 23, 1989 - DELETE MOTORCYCLE SYMBOL SIGN AND SPEED SIGN, ADDED TWO SIGNS
- OCT. 21, 1992 - ADDED A SIGN, REVISED A SIGN DIMENSION & TYPE ERROR & REVISED TITLE BLOCK
- AUG. 08, 1995 - ADDED FLAGGER GRID
- JUNE 30, 2003 - CHANGED REFLECTIVE SHEETING TO ASTM TYPE III OR TYPE VI CHANGED TEXT ON W20-7b SIGN

APPROVED

[Signature]
DIRECTOR OF PROGRAM DEVELOPMENT

[Signature]
TRAFFIC OPERATIONS ENGINEER

[Signature]
FEDERAL HIGHWAY ADMINISTRATION

CONSTRUCTION SIGN DETAILS

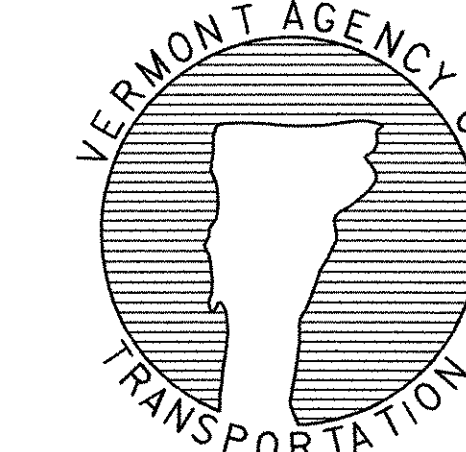

STANDARD E-102

OTHER STDS. E-100 REQUIRED:

NOTE: ALL DIMENSIONS SHOWN IN INCHES EXCEPT WHERE NOTED