

COLD PLANE TYPICAL SECTION - CURBED
MONTPELIER JCT STATE HIGHWAY STA. 0+31.68 TO 2+26

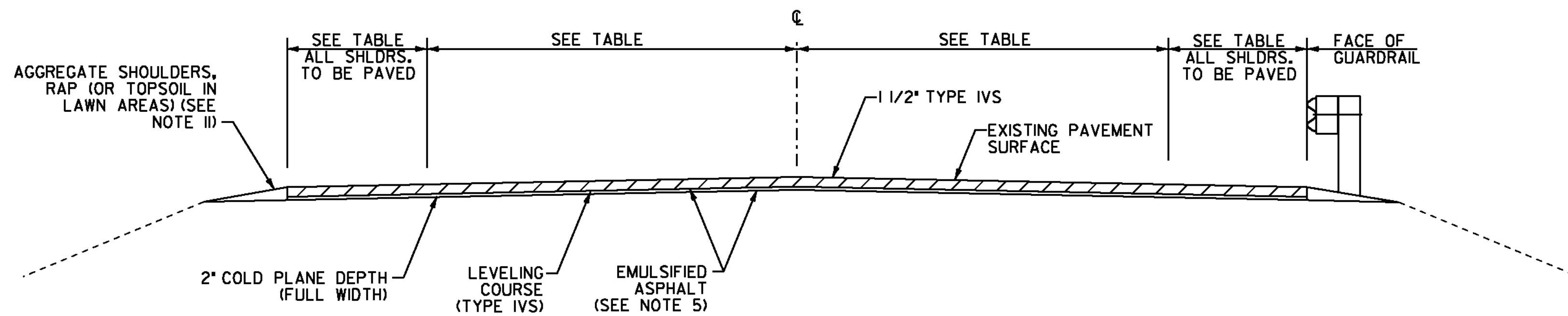

COLD PLANE TYPICAL SECTION - NON-CURBED
MONTPELIER JCT STATE HIGHWAY STA. 2+26 TO 36+59.04

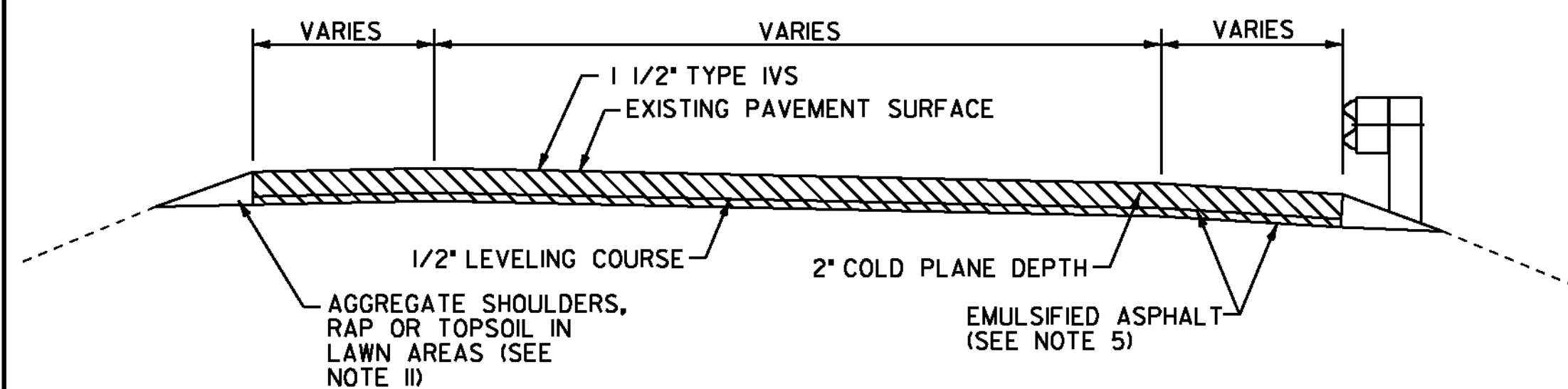

SLIP RAMPS TYPICAL SECTION
FULL ROADWAY WIDTH
SLIP RAMP *M* STA. 0+98 TO 3+08
SLIP RAMP *N* STA. 100+86 TO 103+02

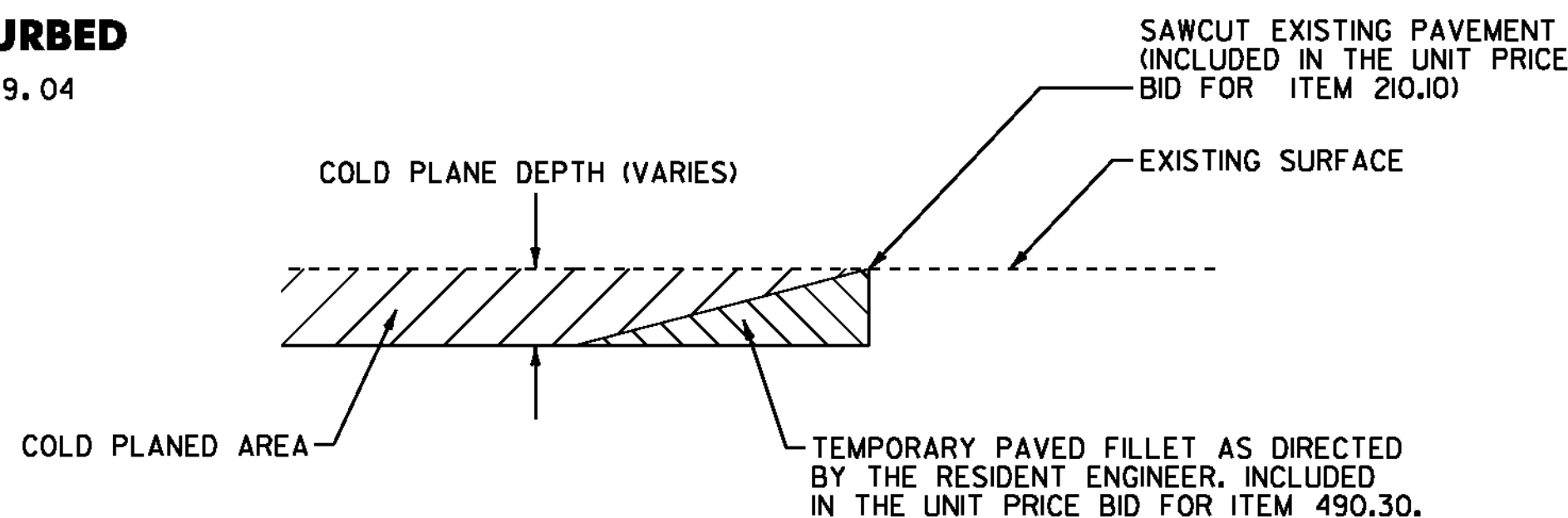

DETAIL AT VERTICAL COLD PLANE JOINTS

NOTE: THIS DETAIL SHALL BE USED AT THE LOCATIONS AND SIDE ROADS LISTED BELOW AND AT ALL DRIVES AS DIRECTED BY THE RESIDENT ENGINEER.

FULL ROADWAY WIDTH
STA. 0+31.68 (BEGIN PROJECT)
STA. 0+98.00 (SLIP RAMP M)
STA. 103+02 (SLIP RAMP N)
STA. 20+73, RT (JUNCTION ROAD)
STA. 36+59.04 (END PROJECT)

PROJECT PAVING LIMITS

TOWN & ROUTE	BEGIN STATION	END STATION	LANE TYPICAL	WEARING DEPTH	LEVELING DEPTH	NOTES
MONTPELIER JCT STATE HIGHWAY MAINLINE	0+31.68	3+32	VARIES - SEE LAYOUT SHEET	1 1/2"	1/2"	COLD PLANE 2", LEVEL, AND THEN PAVE WITH 1 1/2" TYPE IVS.
MONTPELIER JCT STATE HIGHWAY MAINLINE	3+32	20+30	3'-0" - 11'-0" - 11'-0" - 3'-4"	1 1/2"	1/2"	COLD PLANE 2", LEVEL, AND THEN PAVE WITH 1 1/2" TYPE IVS.
MONTPELIER JCT STATE HIGHWAY MAINLINE	20+30	21+16	VARIES - SEE LAYOUT SHEET	1 1/2"	1/2"	COLD PLANE 2", LEVEL, AND THEN PAVE WITH 1 1/2" TYPE IVS.
MONTPELIER JCT STATE HIGHWAY MAINLINE	21+16	23+50	3'-0" - 11'-0" - 11'-0" - 3'-0"	1 1/2"	1/2"	COLD PLANE 2", LEVEL, AND THEN PAVE WITH 1 1/2" TYPE IVS.
MONTPELIER JCT STATE HIGHWAY MAINLINE	23+50	25+50	VARIES - SEE LAYOUT SHEET	1 1/2"	1/2"	COLD PLANE 2", LEVEL, AND THEN PAVE WITH 1 1/2" TYPE IVS.
MONTPELIER JCT STATE HIGHWAY MAINLINE	25+50	26+82	2'-6" - 11'-0" - 11'-0" - 2'-6"	1 1/2"	1/2"	COLD PLANE 2", LEVEL, AND THEN PAVE WITH 1 1/2" TYPE IVS.
MONTPELIER JCT STATE HIGHWAY MAINLINE	26+82	29+75	VARIES - SEE LAYOUT SHEET	1 1/2"	1/2"	COLD PLANE 2", LEVEL, AND THEN PAVE WITH 1 1/2" TYPE IVS.
MONTPELIER JCT STATE HIGHWAY MAINLINE	29+75	30+54	8'-0" - 11'-0" - 11'-0" - 3'-0"	1 1/2"	1/2"	COLD PLANE 2", LEVEL, AND THEN PAVE WITH 1 1/2" TYPE IVS.
MONTPELIER JCT STATE HIGHWAY MAINLINE	30+54	31+22	VARIES - SEE LAYOUT SHEET	1 1/2"	1/2"	COLD PLANE 2", LEVEL, AND THEN PAVE WITH 1 1/2" TYPE IVS.
MONTPELIER JCT STATE HIGHWAY MAINLINE	31+22	36+59.04	3'-0" - 11'-0" - 11'-0" - 3'-0"	1 1/2"	1/2"	COLD PLANE 2", LEVEL, AND THEN PAVE WITH 1 1/2" TYPE IVS.
MONTPELIER JCT STATE HIGHWAY SLIP RAMP M	0+98	3+08	VARIES - SEE LAYOUT SHEET	1 1/2"	1/2"	COLD PLANE 2", LEVEL, AND THEN PAVE WITH 1 1/2" TYPE IVS.
MONTPELIER JCT STATE HIGHWAY SLIP RAMP N	100+86	103+02	VARIES - SEE LAYOUT SHEET	1 1/2"	1/2"	COLD PLANE 2", LEVEL, AND THEN PAVE WITH 1 1/2" TYPE IVS.

NOTES

- THE PAVEMENT WEARING COURSE SHALL BE SUPERPAVE BITUMINOUS CONCRETE PAVEMENT TYPE IVS. THE ESTIMATED 1/2" LEVELING COURSE SHALL BE SUPERPAVE BITUMINOUS CONCRETE PAVEMENT TYPE IVS UNLESS OTHERWISE DIRECTED BY THE RESIDENT ENGINEER.
- GRASS GROWING ADJACENT TO PAVEMENT OR THROUGH CRACKS IN THE PAVEMENT WHICH MAY HAMPER THE PLACEMENT OF NEW BITUMINOUS CONCRETE SHALL BE REMOVED BY THE CONTRACTOR AS DIRECTED BY THE RESIDENT ENGINEER. PAYMENT FOR THIS WORK WILL NOT BE MADE DIRECTLY, BUT WILL BE INCLUDED IN THE UNIT PRICE BID FOR ITEM 490.30 SUPERPAVE BITUMINOUS CONCRETE PAVEMENT.
- SUPERPAVE BITUMINOUS CONCRETE PAVEMENT TOLERANCE = ±1/4". (TOTAL THICKNESS EXCLUDING LEVELING)
- EDGES OF NEW PAVEMENT WITHIN UNCURBED SECTIONS SHALL INCLUDE A SAFETY EDGE AS DIRECTED BY THE RESIDENT ENGINEER. SEE DETAIL ON THE MISCELLANEOUS DETAIL SHEET.
- EMULSIFIED ASPHALT SHALL BE APPLIED ON EXISTING PAVEMENT SURFACES, BETWEEN ALL COURSES OF PAVEMENT AND ON COLD PLANED SURFACES, AT THE RATE OF 0.025 GAL/SY OR AS DIRECTED BY THE RESIDENT ENGINEER.
- COLD PLANING TO BE COMPLETED ACCORDING TO TYPICAL OR AS NOTED OTHERWISE ON THE PLANS. THE COLD PLANING AND PAVING SHALL MATCH THE EXISTING CONDITIONS AT THE BEGINNING AND END OF CONSTRUCTION AREAS BY THE USE OF A VERTICAL COLD PLANE JOINT. SEE DETAIL ON THIS SHEET.
- ALL PUBLIC, PRIVATE OR FIELD DRIVES SHALL RECEIVE A MINIMUM 4' PAVED APRON PAYABLE UNDER ITEM 900.675 SPECIAL PROVISION (HAND-PLACED BITUMINOUS CONCRETE MATERIAL, DRIVES) UNLESS OTHERWISE DIRECTED BY THE RESIDENT ENGINEER. ALL OTHER BITUMINOUS MATERIALS PLACED WITHIN THE PROJECT LIMITS WHETHER BY HAND OR MECHANICAL METHODS SHALL BE PAID AS ITEM 490.30 SUPERPAVE BITUMINOUS CONCRETE PAVEMENT.
- AN ESTIMATED QUANTITY OF ITEM 619.17 YIELDING MARKER POSTS HAS BEEN INCLUDED TO DELINEATE PIPE INLETS, PIPE OUTLETS AND DROP INLETS LOCATED OUTSIDE OF THE PAVEMENT SURFACE OR AS DIRECTED BY THE RESIDENT ENGINEER.
- A QUANTITY FOR ITEM 604.412 REHAB. DROP INLETS, CATCH BASINS, OR MANHOLES, CLASS I, ITEM 604.415 REHAB. DROP INLETS, CATCH BASINS, OR MANHOLES, CLASS II, AND ITEM 604.40 CHANGING ELEVATION OF DI, CB, OR MH HAS BEEN INCLUDED TO BE USED AS INDICATED ON THE PLANS OR AS DIRECTED BY THE RESIDENT ENGINEER. ALL DI'S SHALL BE RAISED OR REHABILITATED SUCH THAT THE NEW GRATE ELEVATION IS EVEN WITH THE SURROUNDING TERRAIN.
- STEEL BEAM GUARDRAIL WITH STEEL POSTS SHALL BE USED ON THIS PROJECT.
- ITEM 402.13 AGGREGATE SHOULDERS, RAP SHALL BE USED TO BACK UP EDGES OF PAVEMENT.

SEEDING FORMULA

RATE: DOUBLE IF HYDROSEEDING

% WT.	LBS./A.	NAME	PUR %	GERM %
38	32	CREeping RED FESCUE	98	90
29	24	SPARTAN HARD FESCUE	95	85
15	12	AZAY SHEEP'S FESCUE	95	87
15	12	ANNUAL RYE GRASS	95	90
3	--	INERTS	--	--
100.0	80 LB/A			

NOTES

- SEED MIXTURE: SHALL NOT HAVE A WEED CONTENT EXCEEDING 0.40% BY WEIGHT AND SHALL BE FREE OF ALL NOXIOUS SEED.
- SEED ITEM 651.5: TO BE APPLIED PER SEEDING FORMULAS OR AS DIRECTED BY THE RESIDENT ENGINEER.
- FERTILIZER ITEM 651.18: FORMULA 10-20-10, TO BE USED WITH SEED, APPLIED AT THE RATE OF 500 LBS./ACRE. (HYDRO SEEDERS MAY USE 19-19-19 FORMULA)
- AGRICULTURAL LIMESTONE ITEM 651.20: TO BE APPLIED AT THE RATE OF 2 TONS/ACRE, OR AS DIRECTED BY THE RESIDENT ENGINEER.
- HAY MULCH ITEM 651.25: TO BE PLACED ON THE EARTH SLOPES AT THE RATE OF 2 TONS/ACRE, OR AS DIRECTED BY THE RESIDENT ENGINEER.
- TOPSOIL ITEM 651.35: TO BE USED WITH SEED AS INDICATED ON THE PLANS, OR AS DIRECTED BY THE RESIDENT ENGINEER.

NOT TO SCALE

PROJECT TYPICAL SHEET

PROJECT NAME: MONTPELIER
PROJECT NUMBER: STP 2902(1)

FILE NAME: p09b318.dgn
PROJECT LEADER: JLL
DESIGNED BY: STANTEC
IPARM FILE: p09b318pts.i

PLOT DATE: 31-MAY-2011
DRAWN BY: STANTEC
CHECKED BY: STANTEC
SHEET 62 OF 79

