

LOCATION: STA. 0+00, RT

COLOR: WHITE DIVIDER & TEXT (RETROREFLECTIVE)
GREEN BACKGROUND (RETROREFLECTIVE)

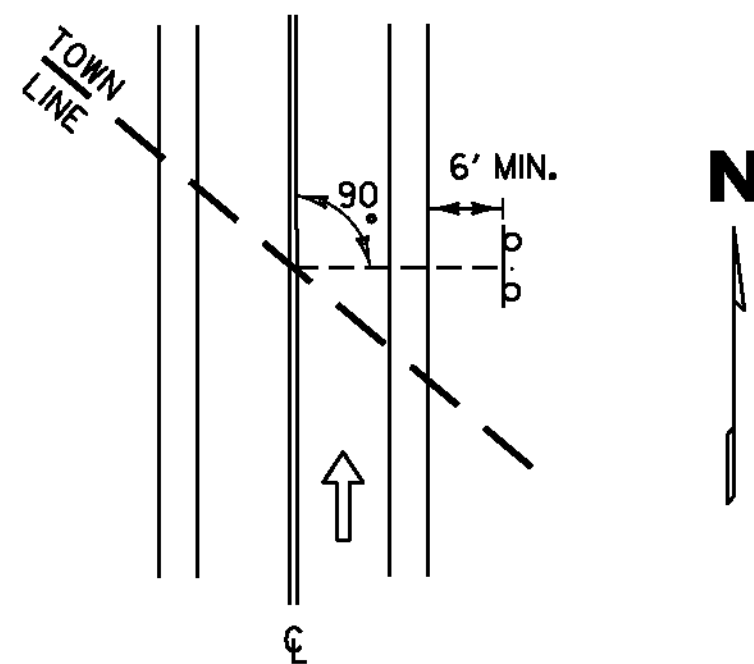
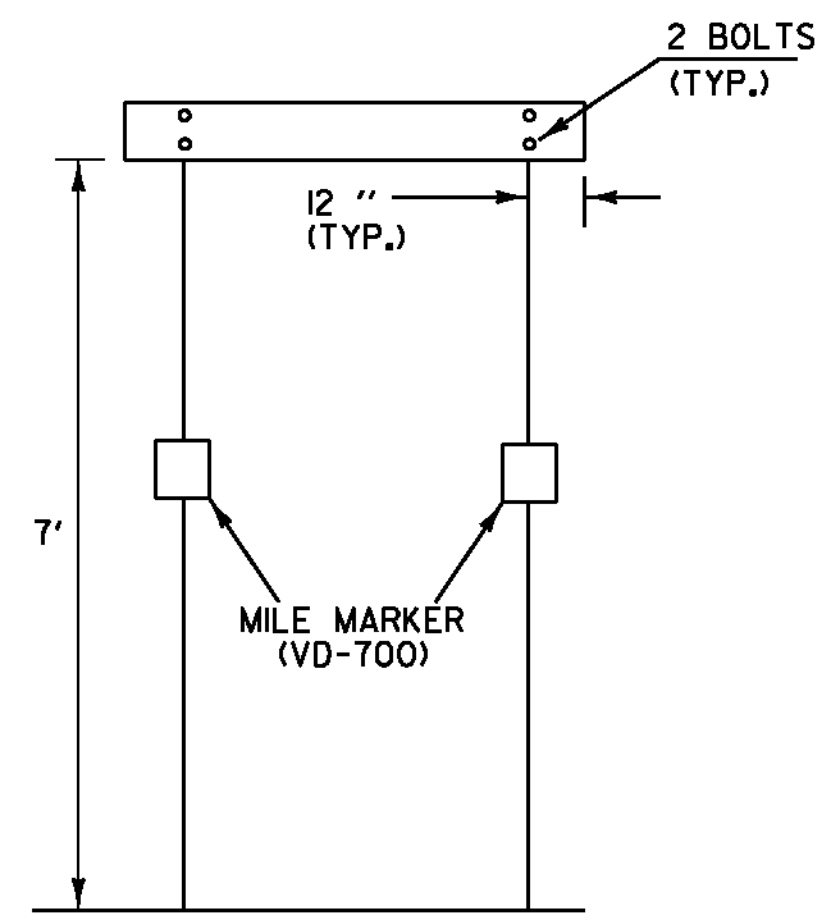

THE SIGN SHALL BE MOUNTED PARALLEL WITH THE ROADWAY, NORMALLY ON RIGHT SIDE TRAVELING WEST TO EAST OR SOUTH TO NORTH.

TOWN LINE SIGN NOTES:

1. WORD TO WORD SPACING FOR MULTIPLE TEXT TOWN NAMES IS ADJUSTABLE TO ACCOMMODATE DIMENSION REQUIREMENTS.
2. DIMENSIONS SHOWN ARE APPROXIMATE AND MAY BE ADJUSTED SLIGHTLY TO ACCOMMODATE VARIOUS MANUFACTURER'S LETTER WIDTHS.
3. ALL DIMENSIONS ARE IN INCHES EXCEPT WHERE NOTED.
4. THE SIGN BASE MATERIAL SHALL BE HIGH DENSITY OVERLAIN PLYWOOD 5/8 INCH THICK OR ALUMINUM SHEETING 0.125" MINIMUM THICKNESS. THE RETROREFLECTIVE MATERIAL SHALL BE SHEETING APPLIED TO THE ENTIRE BACKGROUND OF THE SIGN. THE LEGEND SHALL BE CUT-OUT RETROREFLECTIVE LEGEND. ALL RETROREFLECTIVE MATERIAL SHALL BE EQUAL TO OR EXCEEDING THE "THE AMERICAN SOCIETY OF TESTING AND MATERIALS" (ASTM) TYPE III.
5. SIGNS SHALL HAVE A RETROREFLECTIVE WHITE LEGEND ON A RETROREFLECTIVE GREEN BACKGROUND.
6. LEGEND SHALL CONFORM WITH THE STANDARD ALPHABETS FOR HIGHWAY SIGNS APPROVED BY THE NATIONAL JOINT COMMITTEE ON UNIFORM TRAFFIC CONTROL DEVICES.
7. ALL SIGNS SHALL BE IN ACCORDANCE WITH "THE MANUAL ON UNIFORM TRAFFIC CONTROL DEVICES" (MUTCD) AND THE "STANDARD HIGHWAY SIGNS" BOOK (SHS) PUBLISHED BY THE FEDERAL HIGHWAY ADMINISTRATION (FHWA).

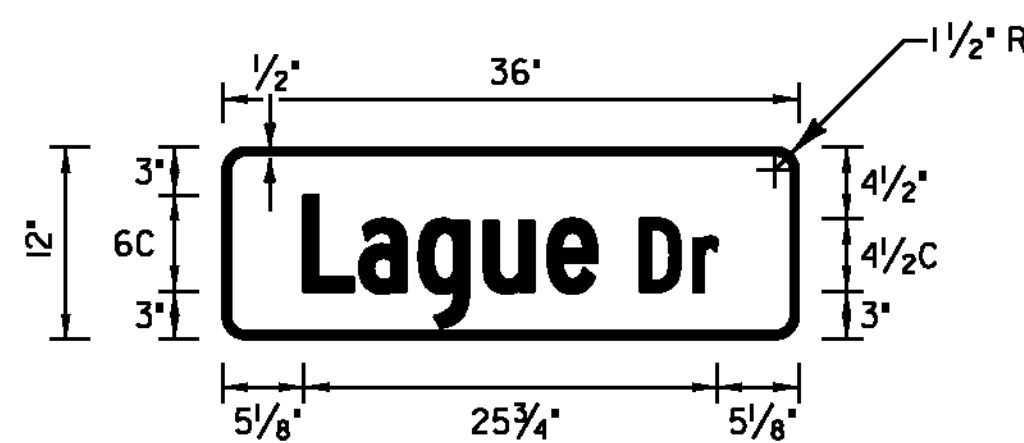

LOCATION: STA. 7+50, LT

COLOR: WHITE BORDER & TEXT (RETROREFLECTIVE)
GREEN BACKGROUND (RETROREFLECTIVE)
MATERIAL: PER VAOT STANDARD E-123

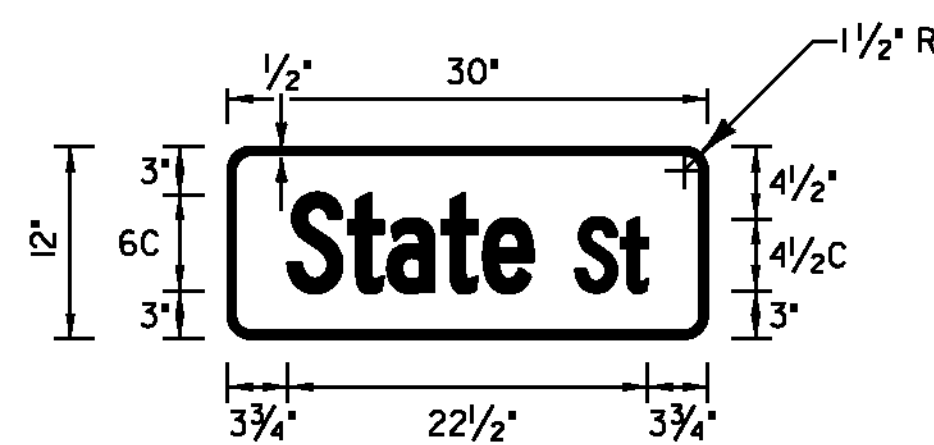

LOCATION: STA. 7+50, LT
STA. 8+39, RT
STA. 13+90, LT
STA. 84+90, RT

COLOR: WHITE BORDER & TEXT (RETROREFLECTIVE)
GREEN BACKGROUND (RETROREFLECTIVE)
MATERIAL: PER VAOT STANDARD E-123

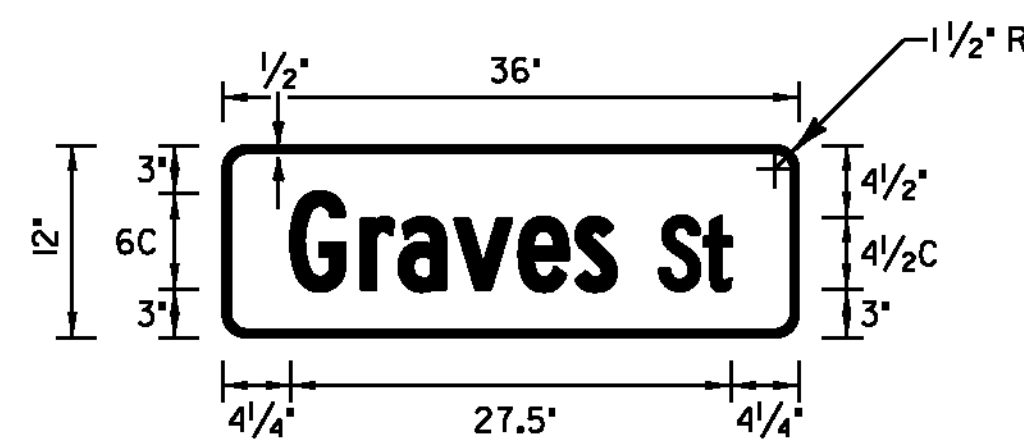

LOCATION: STA. 8+39, RT

COLOR: WHITE BORDER & TEXT (RETROREFLECTIVE)
GREEN BACKGROUND (RETROREFLECTIVE)
MATERIAL: PER VAOT STANDARD E-123

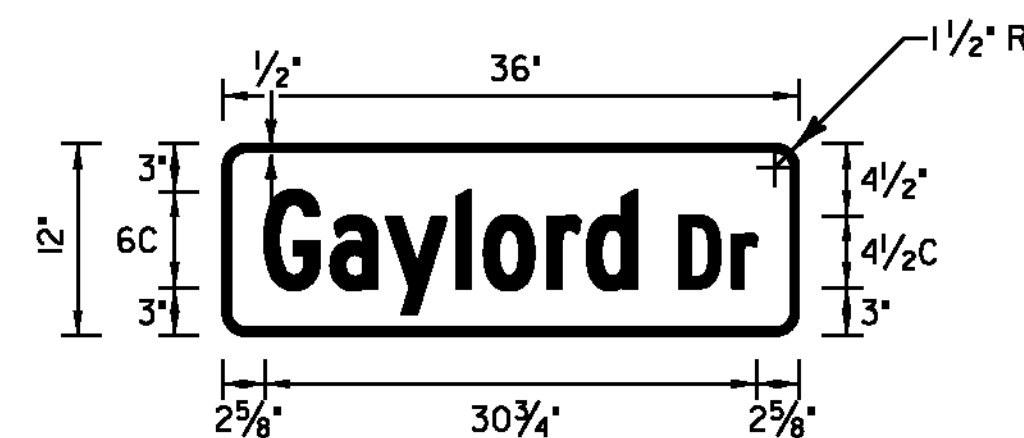

LOCATION: STA. 13+90, LT

COLOR: WHITE BORDER & TEXT (RETROREFLECTIVE)
GREEN BACKGROUND (RETROREFLECTIVE)
MATERIAL: PER VAOT STANDARD E-123

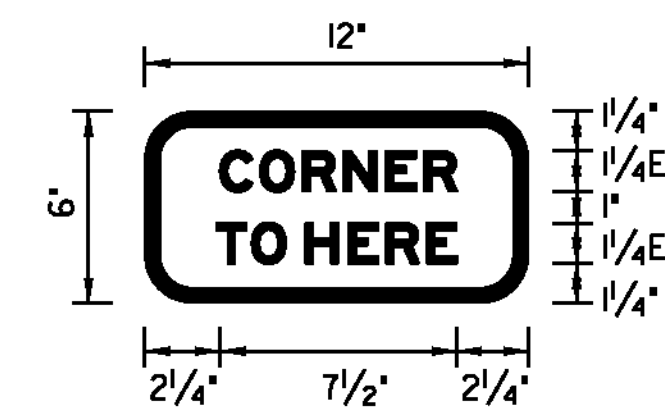

LOCATION: STA. 84+20, LT

COLOR: RED BORDER & TEXT (RETROREFLECTIVE)
WHITE BACKGROUND (RETROREFLECTIVE)
MATERIAL: PER VAOT STANDARD E-123

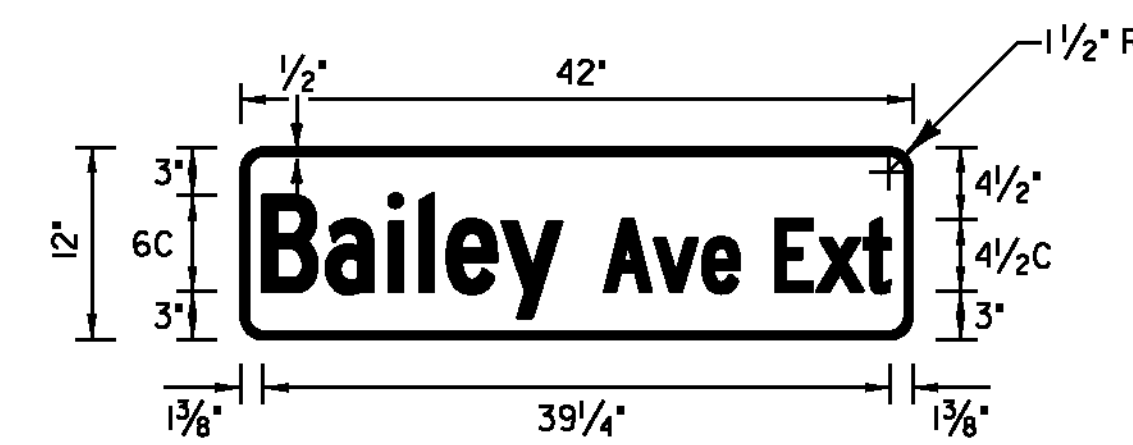

LOCATION: STA. 84+90, RT

COLOR: WHITE BORDER & TEXT (RETROREFLECTIVE)
GREEN BACKGROUND (RETROREFLECTIVE)
MATERIAL: PER VAOT STANDARD E-123

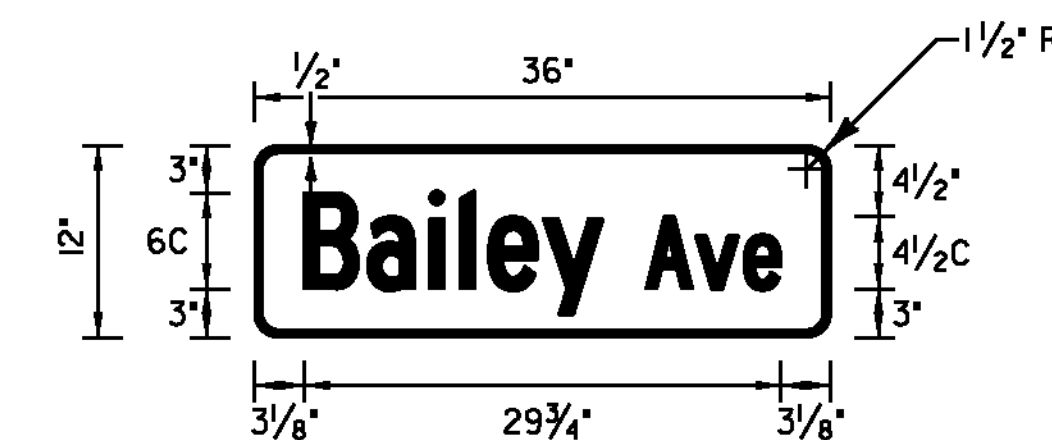

LOCATION: STA. 84+97, LT

COLOR: WHITE BORDER & TEXT (RETROREFLECTIVE)
GREEN BACKGROUND (RETROREFLECTIVE)
MATERIAL: PER VAOT STANDARD E-123

NOT TO SCALE

NOTES: 1. ALL SHEETING SHALL BE TYPE III MINIMUM
2. ALL STREET SIGNS ARE TWO-SIDED

TRAFFIC SIGN DETAIL SHEET #1

PROJECT NAME: MONTPELIER
PROJECT NUMBER: STP 2905(1)

FILE NAME: pl0dl16.dgn
PROJECT LEADER: JLL
DESIGNED BY: STANTEC
IPARM FILE: p10d116tsds01.i

PLOT DATE: 26-MAY-2011
DRAWN BY: STANTEC
CHECKED BY: STANTEC
SHEET 32 OF 79

