

REMOVAL AND REPLACEMENT OF CROSS TIES BETWEEN STA. 1486+80.63 TO STA. 1487+06.71 AND STA. 1487+40.71 TO STA. 1487+66.79 SHALL BE PAID UNDER 900.620 SPECIAL PROVISION (REMOVAL AND REPLACEMENT OF CROSS TIES)

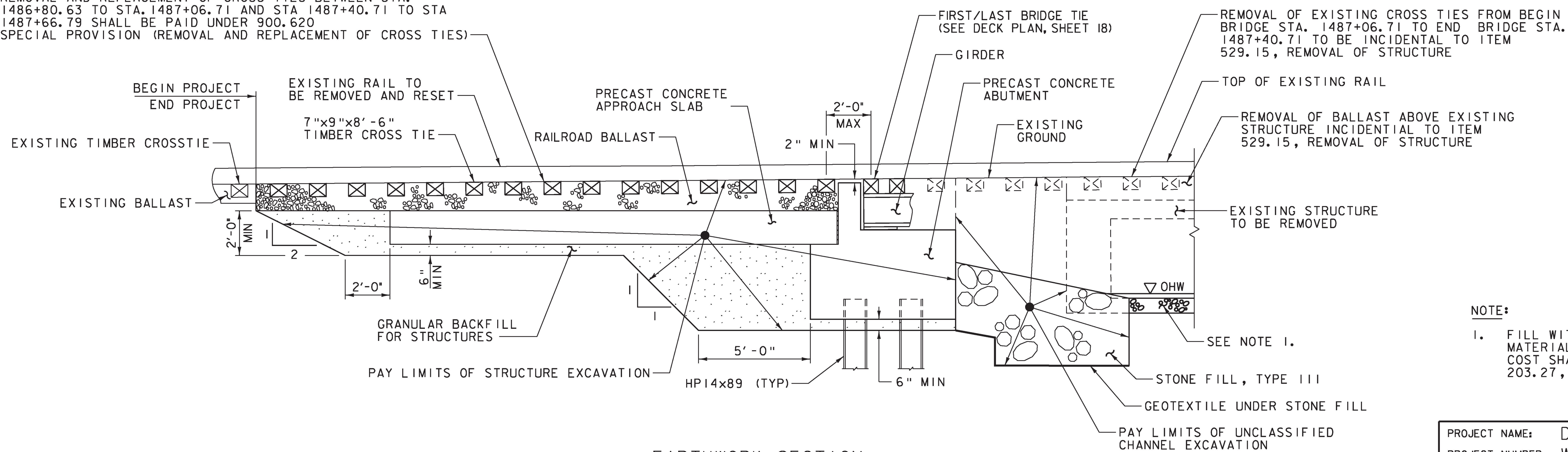

NOTE:

1. FILL WITH SUITABLE ON-SITE EXCAVATED MATERIAL AS APPROVED BY THE ENGINEER. COST SHALL BE INCLUDED UNDER ITEM 203.27, UNCLASSIFIED CHANNEL EXCAVATION.

PROJECT NAME: DORSET
PROJECT NUMBER: WCRS(8)

FILE NAME: z08g224+yp.dgn
PROJECT LEADER: A.P. GUYETTE
DESIGNED BY: J.W. GOLEK
TYPICAL SECTIONS

PLOT DATE: 5/2/2014
DRAWN BY: E.A. FIALA
CHECKED BY: S.E. BURBANK
SHEET 3 OF 33