

646.402 DURABLE 4 INCH WHITE LINE, THERMOPLASTIC
 (ALL LINES WILL INCLUDE EDGE LINE BREAKS
 AND RADII FOR SIDE ROADS)
 STA. 138+00 TO 144+00, SOLID LT & RT

646.412 DURABLE 4 INCH YELLOW LINE, THERMOPLASTIC
 (ALL LINES WILL INCLUDE C BREAKS FOR SIDE ROADS)
 STA. 138+00 TO 144+00, SOLID LT, DASHED RT

646.602 TEMPORARY 4 INCH WHITE LINE, PAINT
 (ALL LINES WILL INCLUDE EDGE LINE BREAKS
 AND RADII FOR SIDE ROADS)
 STA. 138+00 TO 144+00, SOLID LT & RT

646.612 TEMPORARY 4 INCH YELLOW LINE, PAINT
 (ALL LINES WILL INCLUDE C BREAKS FOR SIDE ROADS)
 STA. 138+00 TO 144+00, SOLID LT, DASHED RT

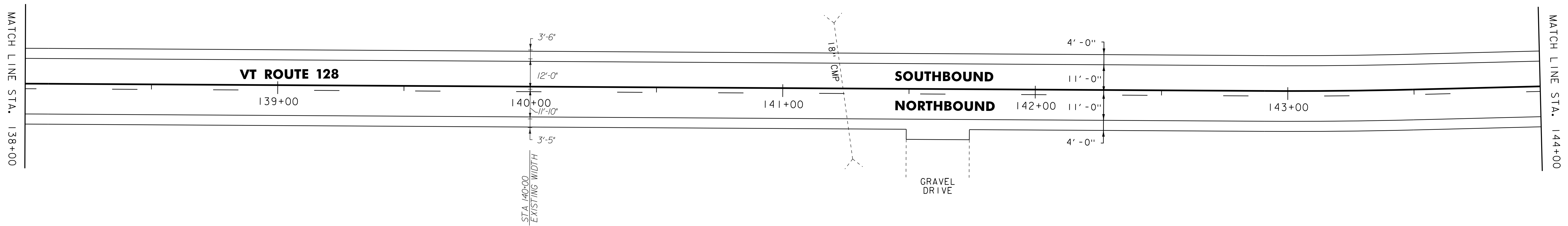

646.402 DURABLE 4 INCH WHITE LINE, THERMOPLASTIC
 (ALL LINES WILL INCLUDE EDGE LINE BREAKS
 AND RADII FOR SIDE ROADS)
 STA. 144+00 TO 150+00, SOLID LT & RT

646.412 DURABLE 4 INCH YELLOW LINE, THERMOPLASTIC
 (ALL LINES WILL INCLUDE C BREAKS FOR SIDE ROADS)
 STA. 144+00 TO 145+46, SOLID LT, DASHED RT
 STA. 145+46 TO 146+78, DASHED C
 STA. 146+78 TO 150+00, DASHED LT, SOLID RT

646.602 TEMPORARY 4 INCH WHITE LINE, PAINT
 (ALL LINES WILL INCLUDE EDGE LINE BREAKS
 AND RADII FOR SIDE ROADS)
 STA. 144+00 TO 150+00, SOLID LT & RT

646.612 TEMPORARY 4 INCH YELLOW LINE, PAINT
 (ALL LINES WILL INCLUDE C BREAKS FOR SIDE ROADS)
 STA. 144+00 TO 145+46, SOLID LT, DASHED RT
 STA. 145+46 TO 146+78, DASHED C
 STA. 146+78 TO 150+00, DASHED LT, SOLID RT

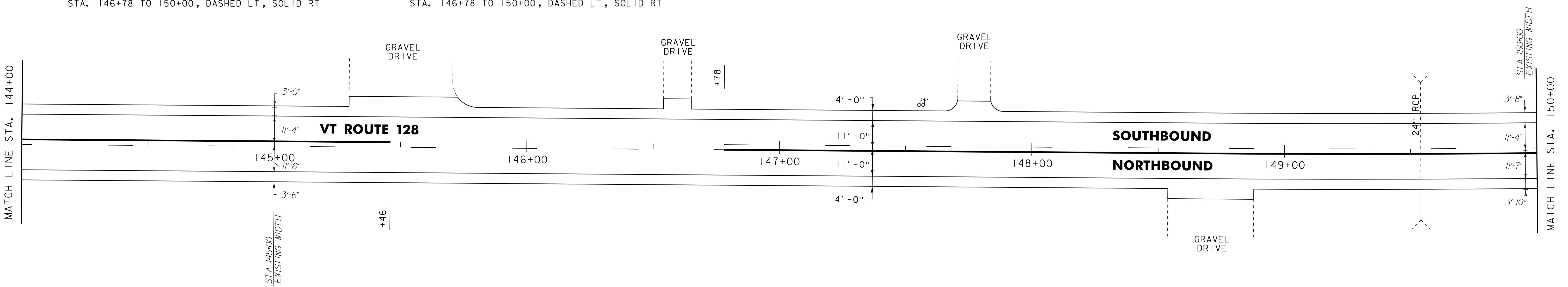

- NOTES:
 1. ALL EXISTING SIGNS NOT SHOWN SHALL BE RETAINED.
 2. FOR LEGENDS, SEE LAYOUT SHEET #1.
NOT TO SCALE



**PROJECT
 LAYOUT
 SHEET #8**

PROJECT NAME: WESTFORD - FAIRFAX
 PROJECT NUMBER: STP 2804(1)

FILE NAME: p08c212.dgn
 PROJECT LEADER: JLL
 DESIGNED BY: STANTEC
 IPARM FILE: p08c212108.i

PLOT DATE: 31-OCT-2012 13:57
 DRAWN BY: STANTEC
 CHECKED BY: JLL
 SHEET 24 OF 79