

COLD PLANE AND OVERLAY TYPICAL SECTION

VT ROUTE 15
STA. 12+01.05 TO STA. 19+51.20

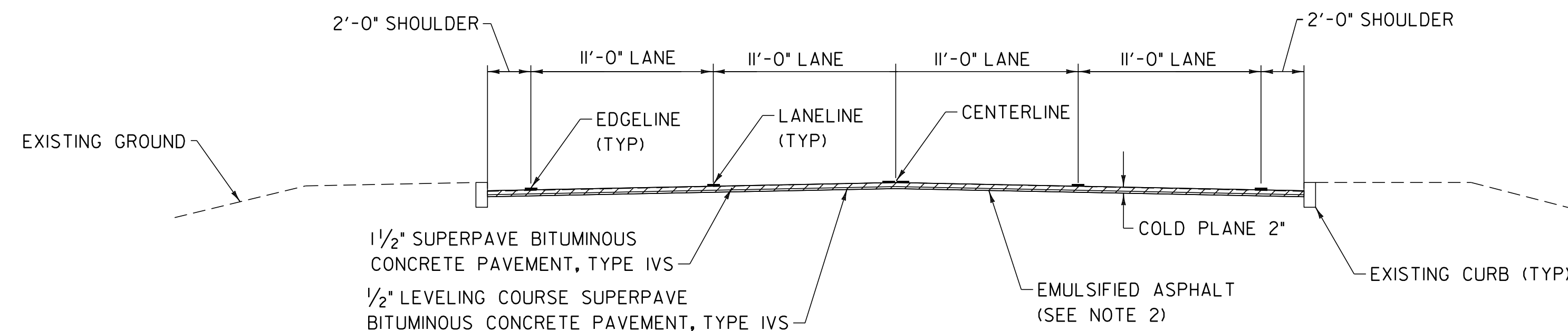

COLD PLANE AND OVERLAY TYPICAL SECTION

VT ROUTE 15
STA. 19+68.98 TO STA. 29+78.81
US ROUTE 7
STA. 1+68.96 TO STA. 2+36.07

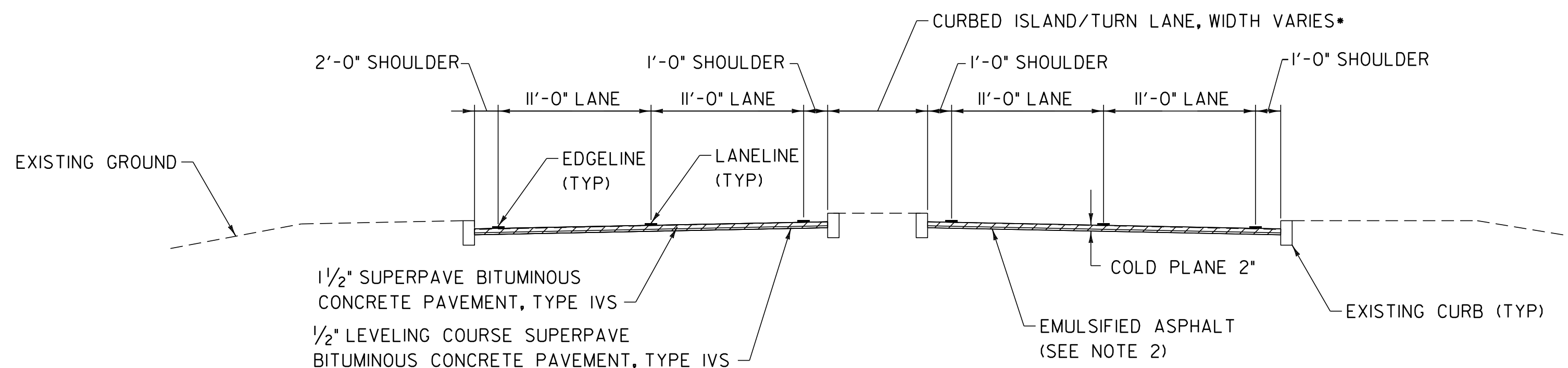

COLD PLANE AND OVERLAY TYPICAL SECTION - CURBED ISLAND

VT ROUTE 15
STA. 29+78.81 TO STA. 39+99.00

* SEE PROJECT PAVING LIMITS TABLE ON PROJECT TYPICAL SHEET 2 OR PROJECT LAYOUT SHEETS FOR DIMENSIONS

**SEEDING FORMULA
URBAN AREAS**

% WT.	LBS./A.	NAME	PUR %	GERM %
42.5	34.0	CREEPING RED FESCUE	98	85
10.0	8.0	PERENNIAL RYE GRASS	95	90
42.5	34.0	KENTUCKY BLUE GRASS	85	85
5.0	4.0	ANNUAL RYE GRASS	95	85
100.00	80.0			

GENERAL NOTES

SEED MIXTURE: SHALL NOT HAVE A WEED CONTENT EXCEEDING 0.40% BY WEIGHT AND SHALL BE FREE OF ALL NOXIOUS SEED.

SEED: TO BE APPLIED PER SEEDING FORMULAS OR AS DIRECTED BY THE ENGINEER.

GENERAL NOTES (CONTINUED)

FERTILIZER: FORMULA 10-20-10, TO BE USED WITH SEED, APPLIED AT THE RATE OF 500 LBS./ACRE. (HYDRO SEEDERS MAY USE 19-19-19 FORMULA).

AGRICULTURAL LIMESTONE: TO BE APPLIED AT THE RATE OF 2 TONS/ACRE, OR AS DIRECTED BY THE ENGINEER.

TOPSOIL: TO BE USED WITH SEED AS INDICATED ON THE PLANS, OR AS DIRECTED BY THE ENGINEER.

YIELDING MARKER POSTS: TO BE PLACED AS INDICATED OR AS DIRECTED BY THE ENGINEER.

NOTES:

1. THE WEARING COURSE SHALL BE TYPE IVS SUPERPAVE BITUMINOUS CONCRETE PAVEMENT. THE LEVELING COURSE SHALL BE TYPE IVS SUPERPAVE BITUMINOUS CONCRETE PAVEMENT. LEVELING HAS BEEN INCLUDED TO RESHAPE THE ROADWAY PRIOR TO PAVING THE TOP COURSE OF PAVEMENT. ALL ASPHALT CEMENT USED IN THE SUPERPAVE BITUMINOUS CONCRETE PAVEMENT SHALL BE AS SPECIFIED IN THE SECTION 490 GENERAL SPECIAL PROVISIONS.
2. EMULSIFIED ASPHALT SHALL BE APPLIED ON ALL EXISTING PAVEMENT SURFACES, ON ALL COLD PLANED SURFACES AND BETWEEN ALL COURSES OF PAVEMENT AT A RATE OF 0.025 GAL / SY OR AS DIRECTED BY THE RESIDENT ENGINEER.
3. SUPERPAVE BITUMINOUS CONCRETE PAVEMENT TOLERANCE = +/- 1/4 INCH (TOTAL PAVEMENT THICKNESS EXCLUDING LEVELING).
4. COLD PLANING SHALL BE COMPLETED ACCORDING TO THE TYPICAL OR AS OTHERWISE NOTED ON THE PLANS. A FULL DEPTH BUTT JOINT SHALL BE CONSTRUCTED AT THE BEGINNING AND END OF THE PROJECT, ALL SIDE ROAD APPROACHES AS DENOTED ON THE PROJECT PLANS OR AS OTHERWISE DIRECTED BY THE RESIDENT ENGINEER. COLD PLANING IS TO BE PAID FOR UNDER ITEM 210.10, "COLD PLANING BITUMINOUS PAVEMENT". PAVING ASSOCIATED WITH THIS WORK IS TO BE PAID FOR UNDER ITEM 490.30 "SUPERPAVE BITUMINOUS CONCRETE PAVEMENT".
5. ALL DRIVES SHALL RECEIVE A PAVED APRON TO THE FRONT EDGE OF THE SIDEWALK AS DIRECTED BY THE RESIDENT ENGINEER. ANY AND ALL REQUIRED EXCAVATION IN DRIVE AREAS SHALL BE AS SHOWN ON THE PLANS OR AS DIRECTED BY THE RESIDENT ENGINEER. THE NEW BITUMINOUS SURFACE SHALL BE CONSTRUCTED AS DIRECTED AND WILL BE PAID FOR UNDER ITEM 900.675, "SPECIAL PROVISION (HAND-PLACED BITUMINOUS CONCRETE MATERIAL, DRIVES)".
6. A QUANTITY FOR ITEM 604.412, "REHABING DI, CB OR MH CLASS I", ITEM 604.415, "REHABING DI, CB OR MH CLASS II", ITEM 604.418, "REHABING DI, CB OR MH CLASS III" AND ITEM 604.40, "CHANGING ELEVATION OF DROP INLETS, CATCH BASINS, OR MANHOLES HAS BEEN INCLUDED IN THE QUANTITIES TO BE USED AS DIRECTED BY THE RESIDENT ENGINEER. ALL D.I.'S SHALL BE RAISED OR REHABILITATED SUCH THAT THE NEW GRATE ELEVATION IS LEVEL WITH THE SURROUNDING TERRAIN. DRAINAGE STRUCTURES CALLING FOR REHABING HAVE BEEN EVENLY DISTRIBUTED BETWEEN ITEMS 604.412, 604.415 AND 604.418 FOR ESTIMATING PURPOSES.
7. YIELDING MARKER POSTS ARE TO BE USED TO REPLACE NON-YIELDING MARKER POSTS AT PIPE INLETS AND OUTLETS ONLY.
8. SEE PROJECT TYPICAL SHEET 2 FOR THINNING AND TRIMMING FOR SIGNS DETAIL AND LOCATIONS WHERE IT IS NEEDED.
9. GRASS GROWING ADJACENT TO PAVEMENT OR THROUGH CRACKS IN THE PAVEMENT WHICH MAY HAMPER THE PLACEMENT OF NEW BITUMINOUS CONCRETE SHALL BE REMOVED BY THE CONTRACTOR AS DIRECTED BY THE ENGINEER. PAYMENT FOR THIS WORK WILL NOT BE MADE DIRECTLY, BUT WILL BE CONSIDERED SUBSIDIARY TO ITEM 490.30, "SUPERPAVE BITUMINOUS CONCRETE PAVEMENT".
10. ESTIMATED QUANTITIES OF SEED, FERTILIZER, AGRICULTURAL LIMESTONE, TOPSOIL, AND TEMPORARY EROSION MATTING HAS BEEN ESTIMATED FOR AREAS DISTURBED BY THE REMOVAL AND RECONSTRUCTION OF PEDESTRIAN RAMPS.
11. AN ESTIMATED QUANTITY OF ITEM 402.13, "AGGREGATE SHOULDERS, RAP" HAS BEEN INCLUDED FOR REPLACEMENT OF POOR BACKING MATERIAL BEHIND GUARDRAIL AS REQUIRED OR AS DIRECTED BY THE RESIDENT ENGINEER.
12. TUBULAR MARKERS TO BE REMOVED IN THE VICINITY OF THE RAILROAD CROSSING SHALL BE RETURNED TO THE CITY. COORDINATE WITH THE CITY OF WINOOSKI ENGINEER; STEVE PALMER (802) 655-6423.

LOOP DETECTOR NOTES

1. THE LOOP DETECTORS SHOWN ON THE PROJECT LAYOUT SHEETS SHALL BE USED AS A GUIDE. THE CONTRACTOR SHALL CONFIRM ALL LOCATIONS, INCLUDING, BUT NOT LIMITED TO, UTILITIES, POLES, PULL BOXES, AND LOOP DETECTORS. THE CONTRACTOR SHALL CONFIRM ALL LOCATIONS IN THE FIELD WITH THE RESIDENT ENGINEER PRIOR TO INSTALLATION.
2. SEE PROJECT LAYOUT SHEETS FOR LOOP DETECTOR REPLACEMENT LOCATIONS.
3. PRIOR TO COLD PLANING, THE CONTRACTOR SHALL DISCONNECT THE VEHICLE DETECTOR LOOP IN THE CONTROLLER CABINET AND CUT IT AT THE CURB OR SHOULDER. ONCE THE VEHICLE DETECTOR LOOP IS DISCONNECTED, THE SIGNAL PHASE THAT IT WAS CALLING SHALL BE SET ON MAXIMUM RECALL OR THE SIGNAL SHALL BE SET TO FLASH WHILE TRAFFIC IS BEING CONTROLLED BY A UNIFORMED TRAFFIC OFFICER. DETECTOR AND SIGNAL WORK SHALL BE INCIDENTAL TO PAY ITEM 678.22, "VEHICLE LOOP DETECTOR". UNIFORMED TRAFFIC OFFICERS WILL BE PAID FOR UNDER CONTRACT ITEM 630.10.
4. ALL PROPOSED VEHICLE DETECTOR LOOPS SHALL BE INSTALLED IN THE LEVELING COURSE, WHICH IS IMMEDIATELY BELOW THE WEARING SURFACE. ONCE THE PROPOSED VEHICLE DETECTOR LOOP IS INSTALLED, THE INDUCTANCE, RESISTANCE AND LEAKAGE TO GROUND MUST BE TESTED USING PROPERLY CALIBRATED EQUIPMENT. THESE TEST RESULTS SHALL BE COMPARED WITH THE CALCULATED VALUES SHOWN ON THE LAYOUT PLANS AND THE FIELD MEASURED VALUES SHALL BE RECORDED ON THE LAYOUT PLANS. UPON COMPLETION OF THE INSTALLATION OF A PROPOSED VEHICLE LOOP DETECTOR, THE SIGNAL SHALL BE RETURNED TO NORMAL OPERATION.
5. THE CONTRACTOR SHALL USE THE EXISTING CONDUIT WHICH RUNS FROM THE CURB TO THE CONTROLLER PANEL FOR THE NEW LOOP DETECTORS.
6. EXISTING TIMINGS WILL BE USED.
7. WORK IMPROVEMENTS CONSISTING OF THOSE SHOWN ON THE PLANS SHALL BE PERFORMED ACCORDING TO SPECIFICATIONS AND STANDARD DRAWINGS OF THE VERMONT AGENCY OF TRANSPORTATION. VEHICLE DETECTOR LOOPS SHALL COMPLY WITH VTRANS STANDARD E-172.

**PROJECT
TYPICAL
SHEET 1**

PROJECT NAME: WINOOSKI
PROJECT NUMBER: STP 2617(1)S

FILE NAME: 06d064.dgn
PROJECT LEADER: CDL
DESIGNED BY: SJL
PLOT FILE: 06D064.56.i

PLOT DATE: 31-OCT-2011 6:46
DRAWN BY: SJL
CHECKED BY: EPD
SHEET 56 OF 88

DETAILS ARE NOT TO SCALE