

TEMPORARY 4 INCH WHITE LINE, PAINT  
 DURABLE 4 INCH WHITE LINE (OPTION BID ITEM)  
 115+50 TO 121+50 SOLID LT & RT

TEMPORARY 4 INCH YELLOW LINE, PAINT  
 DURABLE 4 INCH YELLOW LINE (OPTION BID ITEM)  
 115+50 TO 121+50 SOLID LT & RT

STEEL BEAM GUARDRAIL, GALVANIZED  
 115+83 TO 116+33 RT  
 118+57 TO 118+82 RT

ANCHOR FOR STEEL BEAM RAIL  
 1 (SEE STANDARD G-1d)

REMOVAL AND DISPOSAL OF GUARDRAIL  
 115+83 TO 116+33 RT  
 118+57 TO 118+82 RT

DELINEATOR WITH STEEL POST  
 118+82 RT

REMOVING SIGNS  
 2 - AS SHOWN

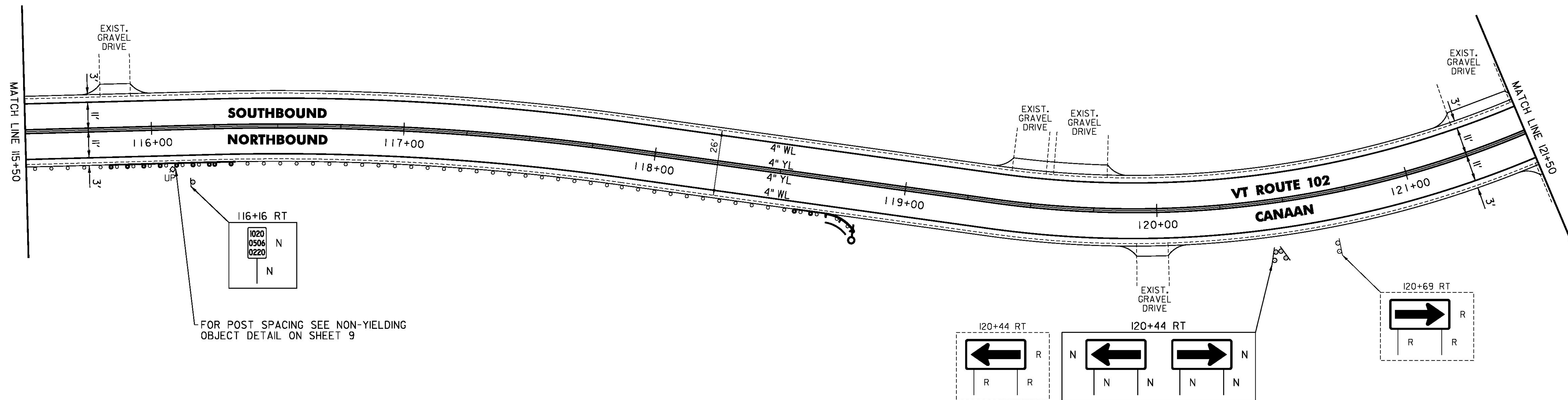

FOR POST SPACING SEE NON-YIELDING  
 OBJECT DETAIL ON SHEET 9

NOT TO SCALE

PROJECT NAME:	LEMINGTON-CANAAN
PROJECT NUMBER:	STP 2723(I)
FILE NAME:	z07c2i4bdr.dgn
PROJECT LEADER:	P. SHEDD
DESIGNED BY:	N. LEMAY
VT 102 PLAN SHEET 53	
PLOT DATE:	2/28/2015
DRAWN BY:	W. GORDON
CHECKED BY:	P. SHEDD
SHEET	76 OF 162

CLD 14-0197