

CHANGING ELEVATION OF SEWER MANHOLES  
STA. 97+15, LT

REHAB D/C CLASS I  
STA 98+25 LT  
STA 99+95 LT

DURABLE 4 INCH WHITE LINE  
(ALL LINES WILL INCLUDE EDGE LINE BREAKS AND  
RADI FOR SIDE ROADS)  
STA. 95+50 TO 101+50, SOLID LT & RT

DURABLE 4 INCH YELLOW LINE  
(ALL LINES WILL INCLUDE C BREAKS FOR SIDE ROADS)  
STA. 95+50 TO 101+50, SOLID LT & RT

TEMPORARY 4 INCH WHITE LINE, PAINT  
(ALL LINES WILL INCLUDE EDGE LINE BREAKS AND  
RADI FOR SIDE ROADS)  
STA. 95+50 TO 101+50, SOLID LT & RT

TEMPORARY 4 INCH YELLOW LINE, PAINT  
(ALL LINES WILL INCLUDE C BREAKS FOR SIDE ROADS)  
STA. 95+50 TO 101+50, SOLID LT & RT

REMOVING SIGNS  
AS SHOWN - 2

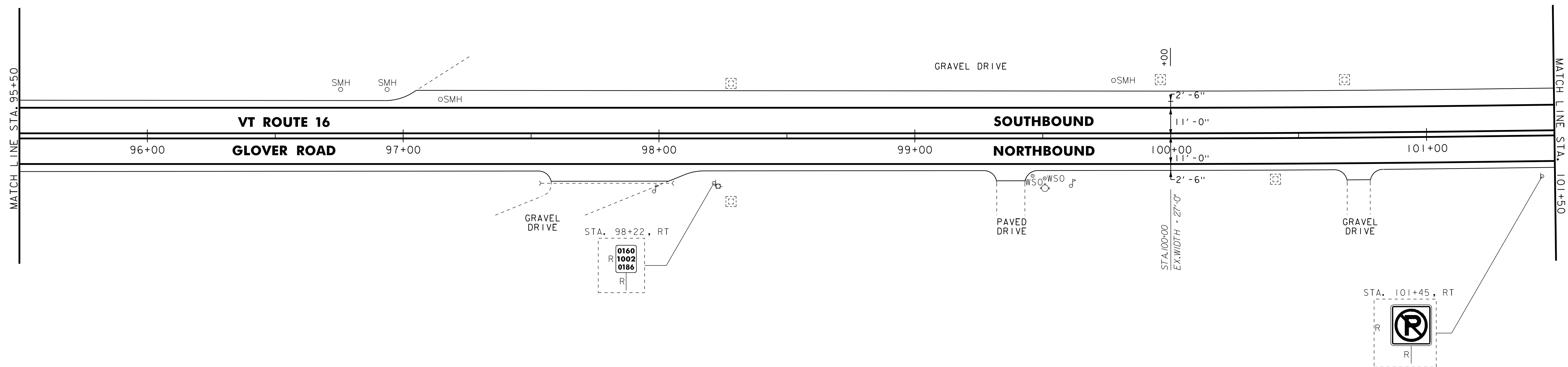

NOTES:  
 1. FOR LEGENDS, SEE SHEET 16.  
 2. ALL EXISTING SIGNS NOT SHOWN SHALL BE RETAINED.  
 3. DURABLE MARKINGS DETAILED ON THIS SHEET ARE OPTION  
 BID ITEMS. SEE SHEETS 5-6.

NOT TO SCALE

<b>PROJECT LAYOUT SHEET #12</b>	PROJECT NAME: BARTON	PLOT DATE: 30-OCT-2013 17:0
	PROJECT NUMBER: STP 2702(I)	DRAWN BY: STANTEC
	FILE NAME: p07c192.dgn	CHECKED BY: STANTEC
	DESIGNED BY: STANTEC	SHEET 28 OF 75
IPARM FILE: p07c192112.i		

