

STEEL BEAM GUARDRAIL, GALVANIZED

STA. 136+52 - STA. 144+75 LT
STA. 142+66.5 - STA. 144+75 RT

STEEL BEAM GUARDRAIL, GALVANIZED W/8 FEET POSTS

STA. 134+10 - STA. 136+22.5 LT
STA. 134+59.5 - STA. 139+09.5 RT

MANUFACTURED TERMINAL SECTION, FLARED

STA. 133+72.5 - STA. 134+10 LT
STA. 134+22 - STA. 134+59.5 RT
STA. 139+09.5 - STA. 139+47 RT
STA. 142+29 - STA. 142+66.5 RT

REMOVAL AND DISPOSAL OF GUARDRAIL

STA. 133+72.5 - STA. 136+22.5 LT
STA. 134+22 - STA. 139+47 RT
STA. 136+52 - STA. 144+75 LT
STA. 142+29 - STA. 144+75 RT

ANCHOR FOR STEEL BEAM RAIL

STA. 136+22.5 LT
STA. 136+52 LT

MATCHLINE STA. 130+50 - SEE PREVIOUS SHEET

MATCHLINE STA. 144+75 SEE BELOW

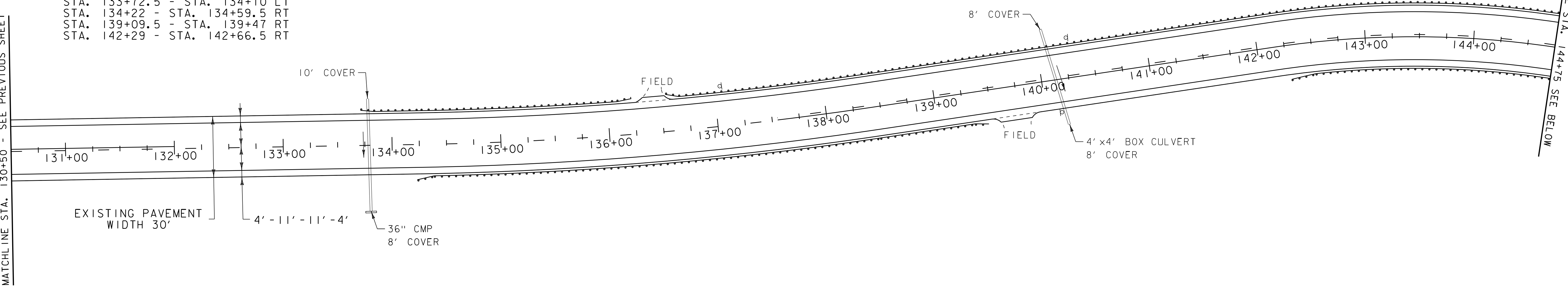
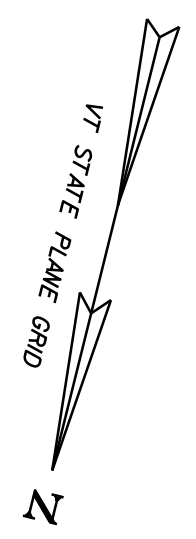

DURABLE 4 INCH WHITE LINE (SEE OPTION ITEMS)

STA. 130+50 - STA. 144+75 (SOLID LT & RT)

TEMPORARY 4 INCH WHITE LINE, PAINT

STA. 130+50 - STA. 144+75 (SOLID LT & RT)

DURABLE 4 INCH YELLOW LINE (SEE OPTION ITEMS)

STA. 130+50 - STA. 132+00 (SOLID LT, DASHED RT, CENTERLINE)
STA. 132+00 - STA. 137+55 (DASHED, CENTERLINE)
STA. 137+55 - STA. 144+75 (DASHED LT, SOLID RT, CENTERLINE)

TEMPORARY 4 INCH YELLOW LINE, PAINT

STA. 130+50 - STA. 132+00 (SOLID LT, DASHED RT, CENTERLINE)
STA. 132+00 - STA. 137+55 (DASHED, CENTERLINE)
STA. 137+55 - STA. 144+75 (DASHED LT, SOLID RT, CENTERLINE)

STEEL BEAM GUARDRAIL, GALVANIZED

STA. 144+75 - STA. 145+14.5 LT
STA. 144+75 - STA. 145+91.5 RT
STA. 153+81 - STA. 158+81 RT

STEEL BEAM GUARDRAIL, GALVANIZED W/8 FEET POSTS

STA. 148+81 - STA. 153+81 RT
STA. 153+93.5 - STA. 155+68.5 LT

MANUFACTURED TERMINAL SECTION, FLARED

STA. 145+14.5 - STA. 145+52 LT
STA. 153+56 - STA. 153+93.5 LT
STA. 155+68.5 - STA. 156+06 LT
STA. 158+81 - STA. 159+18.5 RT

DURABLE 4 INCH WHITE LINE (SEE OPTION ITEMS)

STA. 144+75 - STA. 159+75 (SOLID LT & RT)

DURABLE 4 INCH YELLOW LINE (SEE OPTION ITEMS)

STA. 144+75 - STA. 145+19 (DASHED LT, SOLID RT, CENTERLINE)
STA. 145+19 - STA. 159+75 (SOLID LT & RT, CENTERLINE)

REMOVAL AND DISPOSAL OF GUARDRAIL

STA. 144+75 - STA. 145+39.5 LT
STA. 144+75 - STA. 145+91.5 RT
STA. 148+81 - STA. 159+18.5 RT
STA. 153+56 - STA. 156+06 LT

ANCHOR FOR STEEL BEAM RAIL

STA. 145+91.5 RT
STA. 148+81 RT

TEMPORARY 4 INCH WHITE LINE, PAINT

STA. 144+75 - STA. 159+75 (SOLID LT & RT)

TEMPORARY 4 INCH YELLOW LINE, PAINT

STA. 144+75 - STA. 145+19 (DASHED LT, SOLID RT, CENTERLINE)
STA. 145+19 - STA. 159+75 (SOLID LT & RT, CENTERLINE)

MATCHLINE STA. 144+75 SEE ABOVE



MATCHLINE STA. 159+75 SEE NEXT SHEET

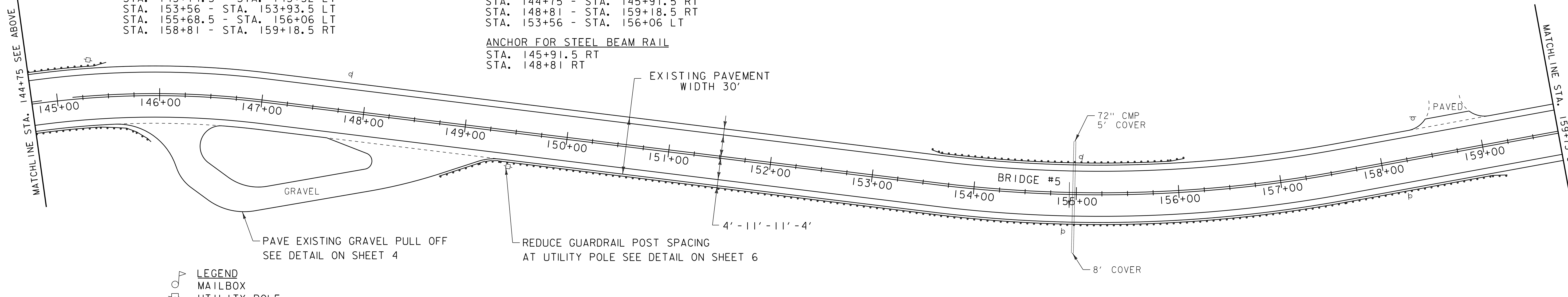

- LEGEND**
- MAILBOX
 - UTILITY POLE
 - HYDRANT
 - MANHOLE
 - WATER VALVE
 - CATCH BASIN / DROP INLET
 - SIGN

DATUM	
VERTICAL	N/A
HORIZONTAL	N/A

PROJECT LAYOUT SHEET 9

PROJECT NAME:	CAMBRIDGE - FAIRFAX
PROJECT NUMBER:	STP 2713(I)
FILE NAME:	p07B182.dgn
PROJECT LEADER:	CDL
DESIGNED BY:	SJL
PLOT FILE:	p07B182.27.1
PLOT DATE:	29-DEC-2014 13:46
DRAWN BY:	SJL
CHECKED BY:	EPD
SHEET	27 OF 36

NOT TO SCALE