

COLD PLANE TYPICAL SECTION - CURBED

BURLINGTON STA. 1+26.72 TO 16+75
 BURLINGTON STA. 40+05 TO 44+37.02
 SOUTH BURLINGTON STA. 0+00 TO 0+70
 SOUTH BURLINGTON STA. 2+55 TO 8+80
 SOUTH BURLINGTON STA. 25+55 TO 49+85
 SOUTH BURLINGTON STA. 54+05 TO 121+33.44

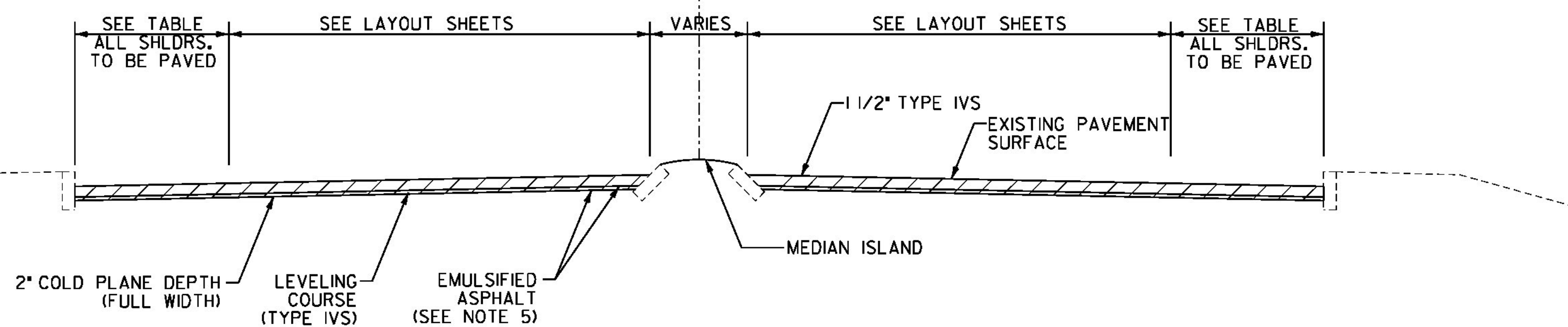

COLD PLANE TYPICAL SECTION - CURBED W/MEDIAN ISLAND

BURLINGTON STA. 16+75 TO 40+05
 SOUTH BURLINGTON STA. 0+70 TO 2+55
 SOUTH BURLINGTON STA. 8+80 TO 15+93
 SOUTH BURLINGTON STA. 18+62 TO 25+55
 SOUTH BURLINGTON STA. 49+85 TO 54+05

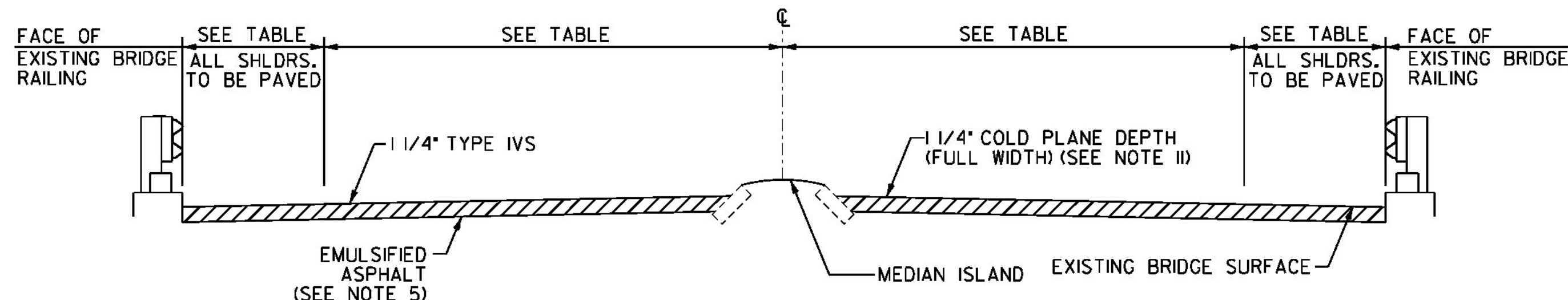

COLD PLANE TYPICAL SECTION - BRIDGE

BR#18C SOUTH BURLINGTON STA. 15+93 TO 18+62

ASPHALTIC PLUG JOINT LOCATIONS

(SEE STRUCTURES DETAIL SD-516.10)

BR#18C SOUTH BURLINGTON STA. 15+93 (81 LF)
 BR#18C SOUTH BURLINGTON STA. 18+62 (81 LF)

PROJECT PAVING LIMITS

TOWN & ROUTE	BEGIN STATION	END STATION	LANE TYPICAL	WEARING DEPTH	LEVELING DEPTH	NOTES
BURLINGTON U.S. ROUTE 2	1+26.72	18+07	VARIABLES - SEE LAYOUT SHEETS	1 1/2"	1/2"	COLD PLANE 2", LEVEL, AND THEN PAVE WITH 1 1/2" TYPE IVS.
BURLINGTON U.S. ROUTE 2	18+07	27+40	1'-0" - 11'-0" - 11'-0" - ISLAND - 11'-0" - 11'-0" - 1'-0"	1 1/2"	1/2"	COLD PLANE 2", LEVEL, AND THEN PAVE WITH 1 1/2" TYPE IVS.
BURLINGTON U.S. ROUTE 2	27+40	31+05	VARIABLES - SEE LAYOUT SHEETS	1 1/2"	1/2"	COLD PLANE 2", LEVEL, AND THEN PAVE WITH 1 1/2" TYPE IVS.
BURLINGTON U.S. ROUTE 2	31+05	36+55	4'-0" - 11'-0" - 11'-0" - ISLAND - 11'-0" - 11'-0" - 4'-0"	1 1/2"	1/2"	COLD PLANE 2", LEVEL, AND THEN PAVE WITH 1 1/2" TYPE IVS.
BURLINGTON U.S. ROUTE 2	36+55	44+37.02	VARIABLES - SEE LAYOUT SHEETS	1 1/2"	1/2"	COLD PLANE 2", LEVEL, AND THEN PAVE WITH 1 1/2" TYPE IVS.
SOUTH BURLINGTON U.S. ROUTE 2	0+00.00	15+93	VARIABLES - SEE LAYOUT SHEETS	1 1/2"	1/2"	COLD PLANE 2", LEVEL, AND THEN PAVE WITH 1 1/2" TYPE IVS.
SOUTH BURLINGTON U.S. ROUTE 2	15+93	18+62	VARIABLES - SEE LAYOUT SHEETS	1 1/4"	-	BR 18C - COLD PLANE 1 1/4" AND THEN PAVE WITH 1 1/4" TYPE IVS.
SOUTH BURLINGTON U.S. ROUTE 2	18+62	30+57	VARIABLES - SEE LAYOUT SHEETS	1 1/2"	1/2"	COLD PLANE 2", LEVEL, AND THEN PAVE WITH 1 1/2" TYPE IVS.
SOUTH BURLINGTON U.S. ROUTE 2	30+57	48+06	2'-0" - 11'-0" - 11'-0" - 11'-0" - 11'-0" - 2'-0"	1 1/2"	1/2"	COLD PLANE 2", LEVEL, AND THEN PAVE WITH 1 1/2" TYPE IVS.
SOUTH BURLINGTON U.S. ROUTE 2	48+06	57+30	VARIABLES - SEE LAYOUT SHEETS	1 1/2"	1/2"	COLD PLANE 2", LEVEL, AND THEN PAVE WITH 1 1/2" TYPE IVS.
SOUTH BURLINGTON U.S. ROUTE 2	57+30	97+20	2'-0" - 11'-0" - 11'-0" - 11'-0" - 11'-0" - 2'-0"	1 1/2"	1/2"	COLD PLANE 2", LEVEL, AND THEN PAVE WITH 1 1/2" TYPE IVS.
SOUTH BURLINGTON U.S. ROUTE 2	97+20	103+97	VARIABLES - SEE LAYOUT SHEETS	1 1/2"	1/2"	COLD PLANE 2", LEVEL, AND THEN PAVE WITH 1 1/2" TYPE IVS.
SOUTH BURLINGTON U.S. ROUTE 2	103+97	119+72	2'-0" - 11'-0" - 11'-0" - 11'-0" - 11'-0" - 2'-0"	1 1/2"	1/2"	COLD PLANE 2", LEVEL, AND THEN PAVE WITH 1 1/2" TYPE IVS.
SOUTH BURLINGTON U.S. ROUTE 2	119+72	121+33.44	VARIABLES - SEE LAYOUT SHEETS	1 1/2"	1/2"	COLD PLANE 2", LEVEL, AND THEN PAVE WITH 1 1/2" TYPE IVS.

NOTES

- THE PAVEMENT WEARING COURSE SHALL BE SUPERPAVE BITUMINOUS CONCRETE PAVEMENT TYPE IVS. THE ESTIMATED 1/2" LEVELING COURSE SHALL BE SUPERPAVE BITUMINOUS CONCRETE PAVEMENT TYPE IVS UNLESS OTHERWISE DIRECTED BY THE RESIDENT ENGINEER.
- GRASS GROWING ADJACENT TO PAVEMENT OR THROUGH CRACKS IN THE PAVEMENT WHICH MAY HAMPER THE PLACEMENT OF NEW BITUMINOUS CONCRETE SHALL BE REMOVED BY THE CONTRACTOR AS DIRECTED BY THE RESIDENT ENGINEER. PAYMENT FOR THIS WORK WILL NOT BE MADE DIRECTLY, BUT WILL BE INCLUDED IN THE UNIT PRICE BID FOR ITEM 490.30 SUPERPAVE BITUMINOUS CONCRETE PAVEMENT.
- SUPERPAVE BITUMINOUS CONCRETE PAVEMENT TOLERANCE = +1/4". (TOTAL THICKNESS EXCLUDING LEVELING)
- EDGES OF PAVEMENT SHALL INCLUDE A SAFETY EDGE AS DIRECTED BY THE RESIDENT ENGINEER. SEE DETAIL ON SHEET 4.
- EMULSIFIED ASPHALT SHALL BE APPLIED ON EXISTING PAVEMENT SURFACES, BETWEEN ALL COURSES OF PAVEMENT AND ON COLD PLANED SURFACES. ALL COLD PLANE SURFACES SHALL HAVE A APPLICATION RATE OF 0.08 GAL/SY OF EMULSIFIED ASPHALT. EMULSIFIED ASPHALT SHALL BE APPLIED ON ALL SUCCESSIVE PAVED SURFACES AT THE RATE OF 0.040 GAL/SY.
- COLD PLANING TO BE COMPLETED ACCORDING TO TYPICAL OR AS NOTED OTHERWISE ON THE PLANS. THE COLD PLANING AND PAVING SHALL MATCH THE EXISTING CONDITIONS AT THE BEGINNING AND END OF CONSTRUCTION AREAS BY THE USE OF A VERTICAL COLD PLANE JOINT. SEE DETAIL ON SHEET 4.
- ALL DRIVES SHALL BE PAVED BACK TO THE EXISTING SIDEWALK OR A DISTANCE OF 4', WHICHEVER IS GREATER. PAYABLE UNDER ITEM 900.675 SPECIAL PROVISION (HAND-PLACED BITUMINOUS CONCRETE MATERIAL, DRIVES) UNLESS OTHERWISE DIRECTED BY THE RESIDENT ENGINEER (FOR DETAILS, SEE SHEET 10). ALL OTHER BITUMINOUS MATERIALS PLACED WITHIN THE PROJECT LIMITS WHETHER BY HAND OR MECHANICAL METHODS SHALL BE PAID AS ITEM 490.30 SUPERPAVE BITUMINOUS CONCRETE PAVEMENT.
- SIDEWALK RAMP DETECTABLE WARNING SURFACES SHALL BE CAST IRON, YELLOW TRUNCATED DOME DETECTABLE WARNING SURFACE FROM THE AGENCY'S APPROVED PRODUCT LIST.
- AN ESTIMATED QUANTITY OF ITEM 619.17 YIELDING MARKER POSTS HAS BEEN INCLUDED TO DELINEATE PIPE INLETS, PIPE OUTLETS AND DROP INLETS LOCATED OUTSIDE OF THE PAVEMENT SURFACE OR AS DIRECTED BY THE RESIDENT ENGINEER.
- A QUANTITY FOR ITEM 604.412 REHAB. DROP INLETS, CATCH BASINS, OR MANHOLES, CLASS I, ITEM 604.415 REHAB. DROP INLETS, CATCH BASINS, OR MANHOLES, CLASS II, ITEM 604.418 REHAB. DROP INLETS, CATCH BASINS, OR MANHOLES, CLASS III AND ITEM 604.40 CHANGING ELEVATION OF DI, CB, OR MH HAS BEEN INCLUDED TO BE USED AS INDICATED ON THE PLANS OR AS DIRECTED BY THE RESIDENT ENGINEER. ALL DI'S SHALL BE RAISED OR REHABILITATED SUCH THAT THE NEW GRATE ELEVATION IS EVEN WITH THE SURROUNDING TERRAIN. DRAINAGE STRUCTURE REHABILITATIONS HAVE BEEN DISTRIBUTED BETWEEN ITEMS 604.412, 604.415 AND 604.418 FOR ESTIMATING PURPOSES.
- THE CONTRACTOR MUST USE CARE WHEN COLD PLANING BRIDGE #18C SO AS NOT TO DAMAGE THE BRIDGE MEMBRANE. IF DAMAGE TO THE MEMBRANE SHOULD OCCUR DURING THE COLD PLANING OF BRIDGE #18C, THE CONTRACTOR SHALL REPLACE THE BRIDGE MEMBRANE AT NO COST TO THE STATE.
- COLD PLANE SURFACES WITHIN THE COLD PLANE TYPICAL SECTIONS SHALL HAVE SURFACE PREPARATION BEFORE THE LEVELING COURSE IS LAID. SURFACE PREPARATION SHALL CONSIST OF POT HOLE PATCHING AND PATCHING OF ALL LARGE CRACKS THAT ARE AT LEAST 1" IN WIDTH. PAYMENT WILL BE UNDER ITEM 900.680, SPECIAL PROVISION BITUMINOUS CONCRETE PAVEMENT SURFACE PREPARATION, TYPE I (SEE DETAIL ON SHEET 4).

SEEDING FORMULA

RATE: DOUBLE IF HYDROSEEDING

% WT.	LBS./A.	NAME	PUR %	GERM %
38	32	CREeping RED FESCUE	98	90
29	24	SPARTAN HARD FESCUE	95	85
15	12	AZAY SHEEP'S FESCUE	95	87
15	12	ANNUAL RYE GRASS	95	90
3	-	INERTS	--	--
100.0	80 LB/A			

NOTES

- SEED MIXTURE: SHALL NOT HAVE A WEED CONTENT EXCEEDING 0.40% BY WEIGHT AND SHALL BE FREE OF ALL NOXIOUS SEED.
- SEED ITEM 651.5: TO BE APPLIED PER SEEDING FORMULAS OR AS DIRECTED BY THE RESIDENT ENGINEER.
- FERTILIZER ITEM 651.18: FORMULA 10-20-10, TO BE USED WITH SEED, APPLIED AT THE RATE OF 500 LBS./ACRE. (HYDRO SEEDERS MAY USE 19-19-19 FORMULA)
- AGRICULTURAL LIMESTONE ITEM 651.20: TO BE APPLIED AT THE RATE OF 2 TONS/ACRE, OR AS DIRECTED BY THE RESIDENT ENGINEER.
- HAY MULCH ITEM 651.25: TO BE PLACED ON THE EARTH SLOPES AT THE RATE OF 2 TONS/ACRE, OR AS DIRECTED BY THE RESIDENT ENGINEER.
- TOPSOIL ITEM 651.35: TO BE USED WITH SEED AS INDICATED ON THE PLANS, OR AS DIRECTED BY THE RESIDENT ENGINEER.

NOT TO SCALE

PROJECT TYPICAL SHEET #1

PROJECT NAME: BURLINGTON-SOUTH BURLINGTON
 PROJECT NUMBER: NH 2624(I)
 FILE NAME: p06d216.dgn
 PROJECT LEADER:
 DESIGNED BY: STANTEC
 IPARM FILE: p06d216s01.i
 PLOT DATE: 2/7/2012
 DRAWN BY: STANTEC
 CHECKED BY: STANTEC
 SHEET 3 OF 108

