

FIRE HYDRANT PAVEMENT MARKING DETAIL

VT. ROUTE 67A BENNINGTON: STA 10+31.0 RT
 STA 106+89.0 RT
 STA 109+46.0 RT

VT. ROUTE 67 BENNINGTON (NORTH BENNINGTON): STA 15+64.0 LT
 STA 26+26.0 RT
 STA 29+65.0 RT

NOTE:

- I. THE CONTRACTOR SHALL ADJUST THE PLACEMENT OF THE FIRE HYDRANT PAVEMENT MARKINGS TO MEET THE EXISTING SITE CONSTRAINTS AS DIRECTED BY THE RESIDENT ENGINEER.

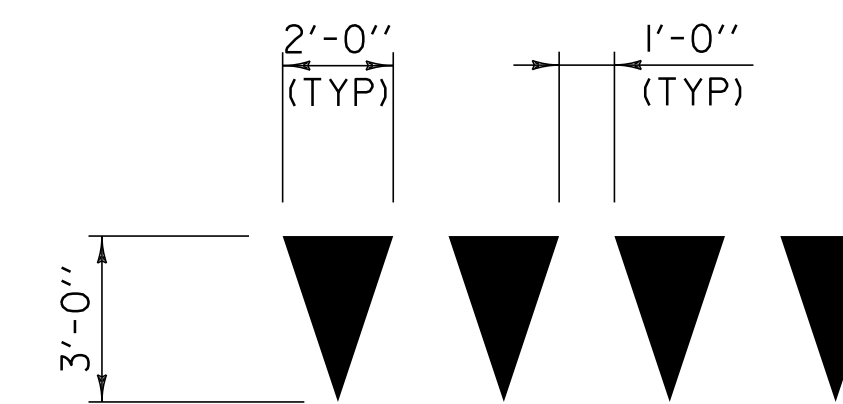

YIELD LINE DETAILS

VT. ROUTE 67A BENNINGTON: STA 17+30.00 LT
 STA 27+90.00 LT

VT. ROUTE 67 BENNINGTON (NORTH BENNINGTON): STA 23+10.00 RT

NOTE:

- I. UNDER THE STP 2626(I) PROJECT, EACH TRIANGLE SHALL BE PAID AS ONE EACH ITEM 646.492 DURABLE LETTER OR SYMBOL, THERMOPLASTIC AND 646.692 TEMPORARY LETTER OR SYMBOL, PAINT. UNDER THE STP 2622(I) PROJECT, EACH TRIANGLE SHALL BE PAID AS ONE EACH ITEM 646.490 DURABLE LETTER OR SYMBOL AND 646.692 TEMPORARY LETTER OR SYMBOL.

NOT TO SCALE

COMPOSITE MISCELLANEOUS DETAILS SHEET	PROJECT NAME: BENNINGTON & BENNINGTON (NORTH BENNINGTON) CLASS I	
	PROJECT NUMBER: STP 2626(I) & STP 2622(I)	
	FILE NAME: p06b220.dgn	PLOT DATE: 07-MAY-2012 14:2
	PROJECT LEADER: D.E.G.	DRAWN BY: C.A.K.
DESIGNED BY: M.J.L.	CHECKED BY: D.E.G.	
DWG. NO. p06b220md.i		SHEET 8 OF 69