

ABUTMENT 1 DOWNSPOUT ELEVATION
 (ABUTMENT 1 ELEVATION SHOWN, ABUTMENT 2 SIMILAR)
 SCALE 1/10

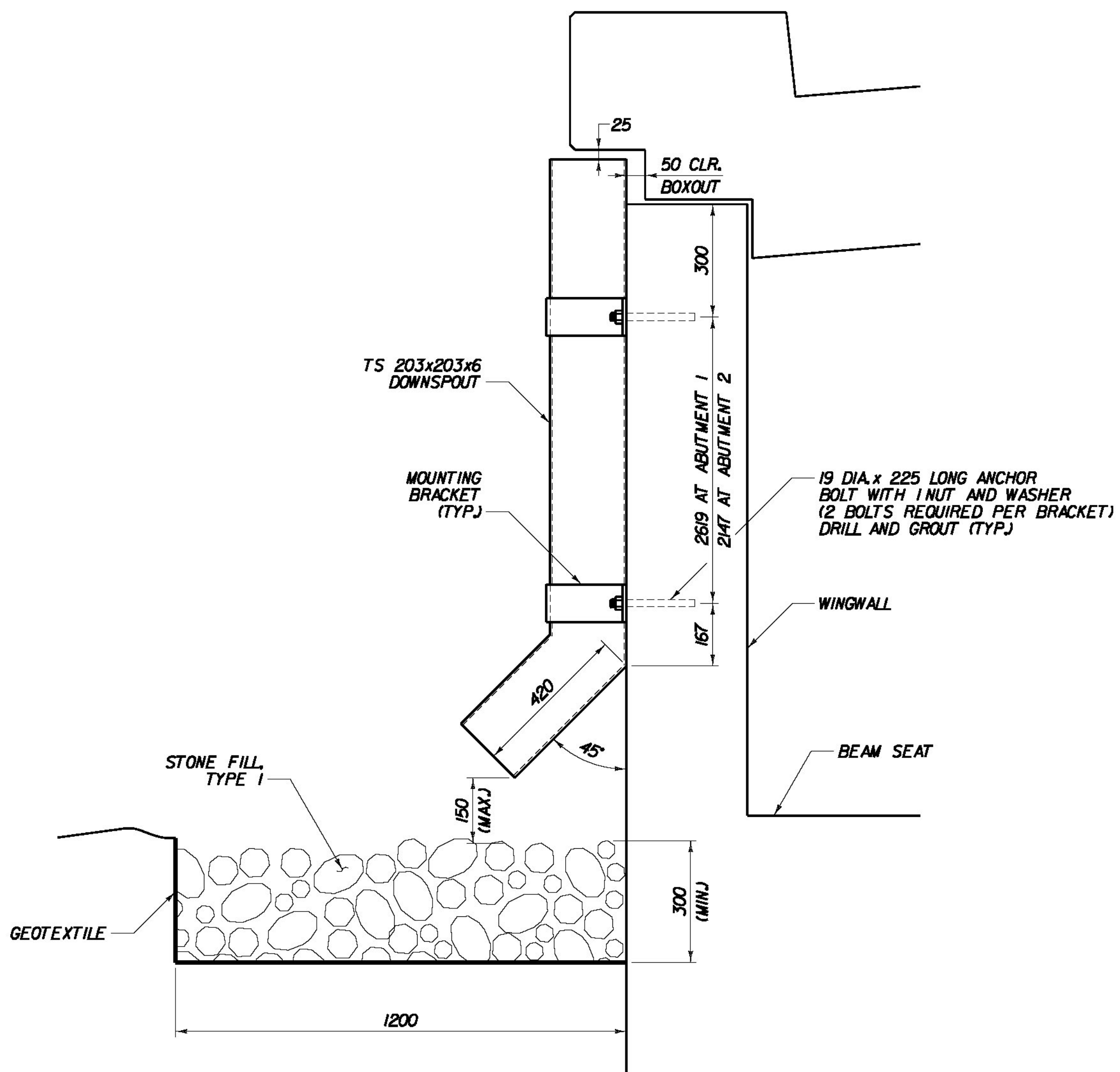

ABUTMENT 1 - SECTION A-A
 (ABUTMENT 1 SECTION SHOWN, ABUTMENT 2 SIMILAR EXCEPT WHERE NOTED)
 SCALE 1/10

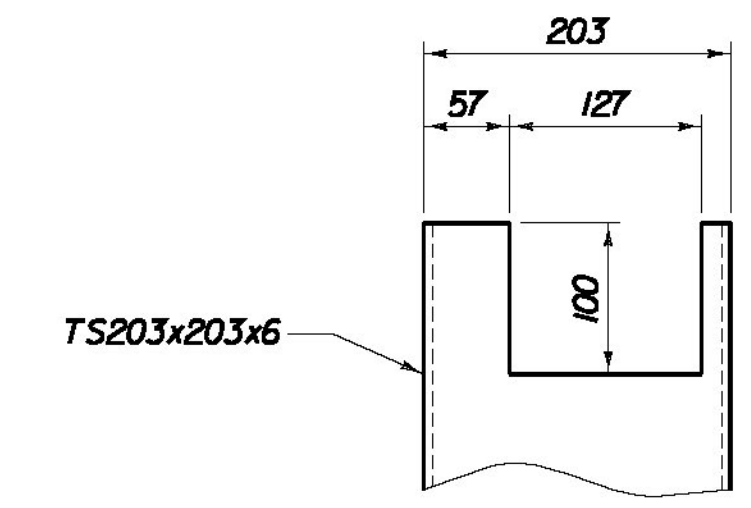

DOWNSPOUT CUTOUT FOR TROUGH
 SCALE 1/5

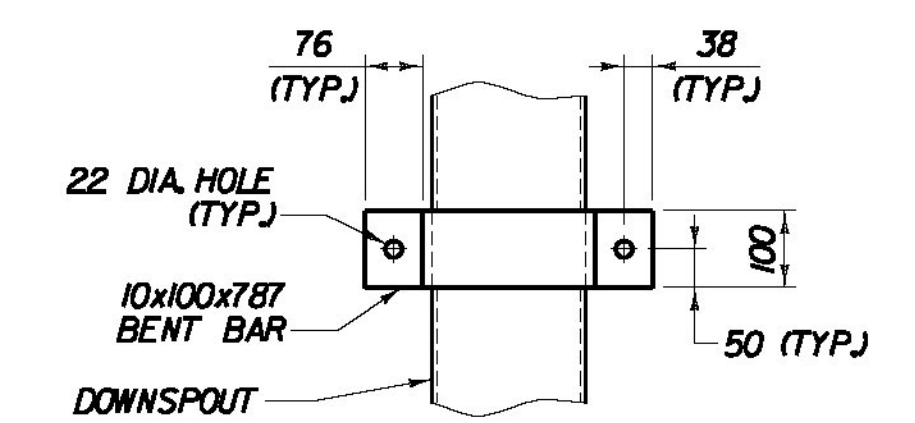

MOUNTING BRACKET ELEVATION
 SCALE 1/10

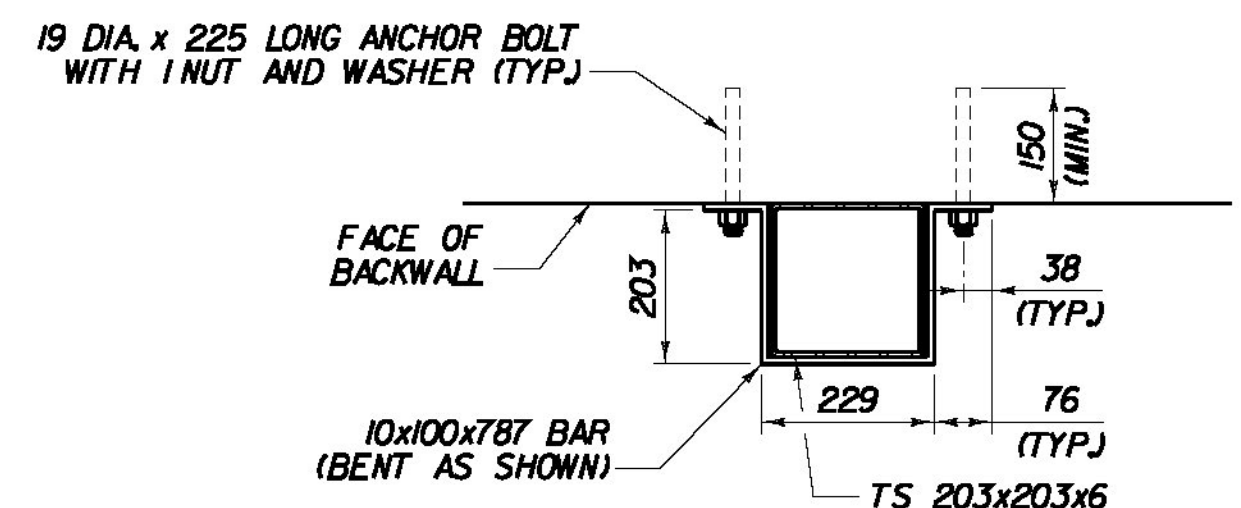

MOUNTING BRACKET DETAIL
 SCALE 1/10

DOWNSPOUT NOTES

- HOLLOW STRUCTURAL STEEL TUBING SHALL CONFORM TO ASTM A500 GRADE B OR A501
- ALL PLATES, BARS, AND ANGLES SHALL CONFORM TO AASHTO M 270M/M270 GRADE 250 AND SHALL BE GALVANIZED.
- DOWNSPOUTS SHALL BE GALVANIZED IN ACCORDANCE WITH SUBSECTION 506J6 PART (a) AFTER FABRICATION.
- ALL BOLTS AND RELATED HARDWARE SHALL CONFORM TO SUBSECTION 714D4 AND SHALL BE GALVANIZED IN ACCORDANCE WITH SUBSECTION 506J5, PART (a).
- WHERE THE GALVANIZING HAS BEEN REMOVED FROM THE DOWNSPOUT OR RELATED HARDWARE EITHER BY CUTTING, BURNING, WELDING, PLACING OR ANY OTHER MEANS, IT SHALL BE REPAIRED IN ACCORDANCE WITH SECTION 513.
- ALL MATERIALS AND INSTALLATION COSTS FOR THE DOWNSPOUTS, INCLUDING STEEL TUBING, MOUNTING BRACKETS, BACKUP PLATE, ANCHOR BOLTS, NUTS, WASHERS AND DRILLING AND GROUTING BOLTS SHALL BE PAID FOR UNDER ITEM 506.60, STRUCTURAL STEEL.
- THE CONTRACTOR SHALL VERIFY ALL DIMENSIONS, PRIOR TO FABRICATION.

STATE OF VERMONT AGENCY OF TRANSPORTATION

Town Of	BENNINGTON	Bridge No.	145
Highway No.		Log Sta.	
		Surv. Sta.	
US ROUTE 7 SB OVER VT ROUTE 279 WB			
DOWNSPOUT DETAILS			
Designed By	M. CHENETTE	Drawn By	J. SOTER
Checked By		Date	
	M. CHENETTE	11/09	G. BOGUE
PROJECT	BENNINGTON	PROJECT NO.	NH F019-(154)



1/26/2010 4:55:39 PM v:\953\cvt\15e\953\002\struc\cur\dwg\design\ab1.dwg - file:9530 - SI:TSB-DOWNSPOUT.rvt