

DETAIL A

NOTES

1. SEE STANDARD G-1 & G-1D FOR STEEL BEAM GUARDRAIL DETAILS.
2. THIS WORK SHALL BE PAID UNDER ITEM 621.20, STEEL BEAM GUARDRAIL, GALVANIZED AND ITEM 900.640, SPECIAL PROVISION, (STEEL BEAM GUARDRAIL, GALVANIZED/NESTED) AT A PAY FACTOR OF 1.0
3. THIS DETAIL TO BE USED AS INDICATED ON THE ITEM DETAIL SHEET, OR AS DIRECTED BY THE RESIDENT ENGINEER.

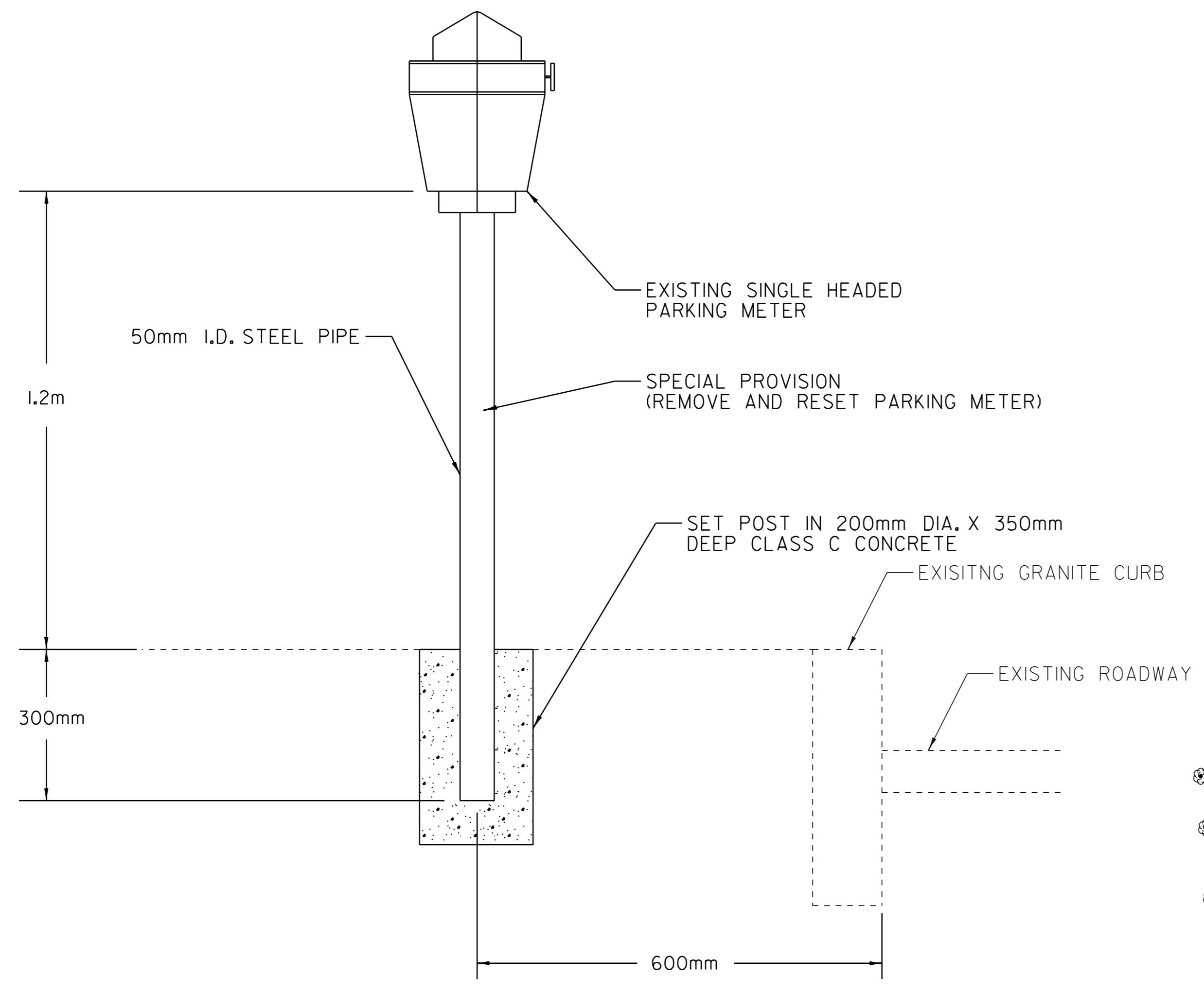

PARKING METER POST SETTING

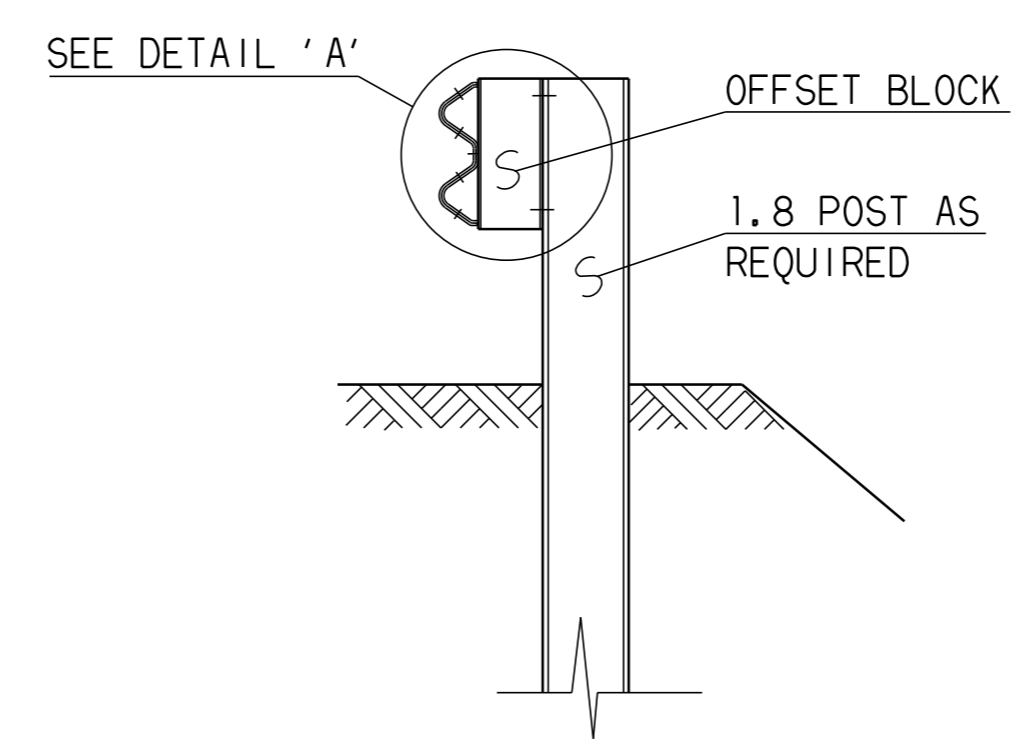

SECTION A-A

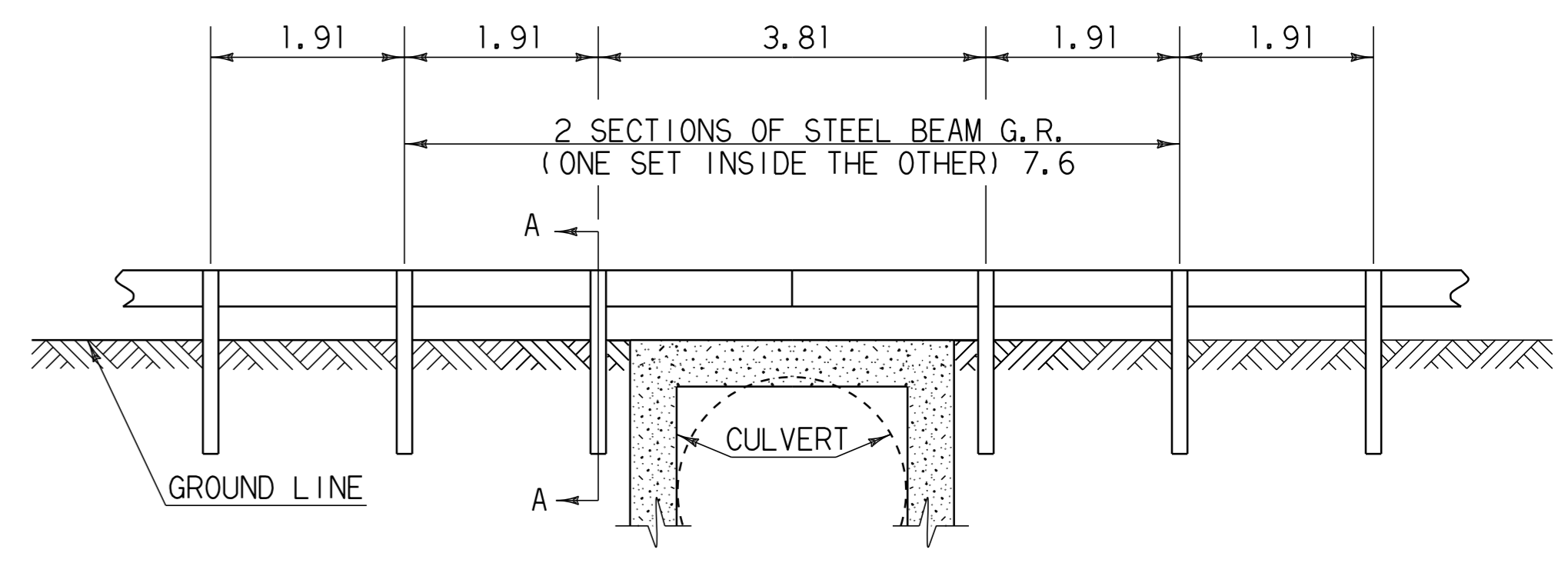

STEEL BEAM GUARDRAIL AT SMALL CULVERTS DETAIL

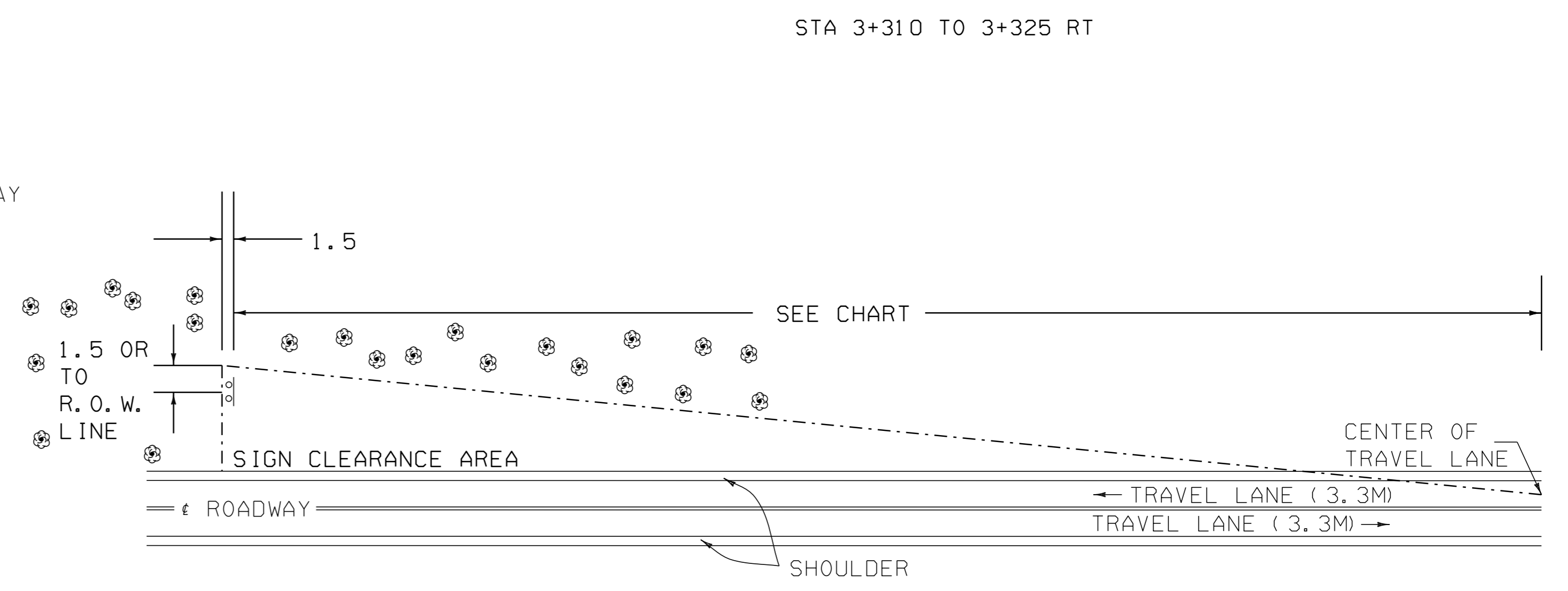

THE CONTRACTOR SHALL REMOVE ALL WOODY STEMMED GROWTH INCLUDING BRUSH, SAPLINGS AND TREE LIMBS GROWING WITHIN OR PROJECTING INTO THE CLEARANCE AREA AND DOWN TO GROUND LEVEL. PAYMENT WILL BE FOR THINNING AND TRIMMING FOR SIGNS, ITEM 201.31 AND PAID FOR AS EACH. NO CHEMICALS (POISONS OR DEFOLIANTS) WILL BE ALLOWED.

MINIMUM SIGN SIGHT DISTANCE CHART

APPROACH SPEED (km/hr)	SIGHT DISTANCE (meters)
50 OR LESS	91
55	107
65	122
70	137
80	152
90	168

THINNING AND TRIMMING DETAIL

STA 1+003 RT
STA 1+235 LT
STA 1+460 RT

NOTE: ALL DIMENSIONS IN METERS EXCEPT AS INDICATED

MISC. DETAILS SHEET	PROJECT NAME: WOODSTOCK	DESIGN FILE NAME: /pave/06b036/pb036.dgn	PLOT DATE: 11-JUN-2012 16:15
	PROJECT NUMBER: NH 2606(1)S	IPARM FILE NAME: pb036d+05.i	DRAWN BY: MRS
	PROJECT LEADER: PTS	DESIGNED BY: NULL	CHECKED BY: NULL
	DESIGNED BY: NULL		SHEET 18 OF 73