

REMOVE SIGNS
AS SHOWN -14
15

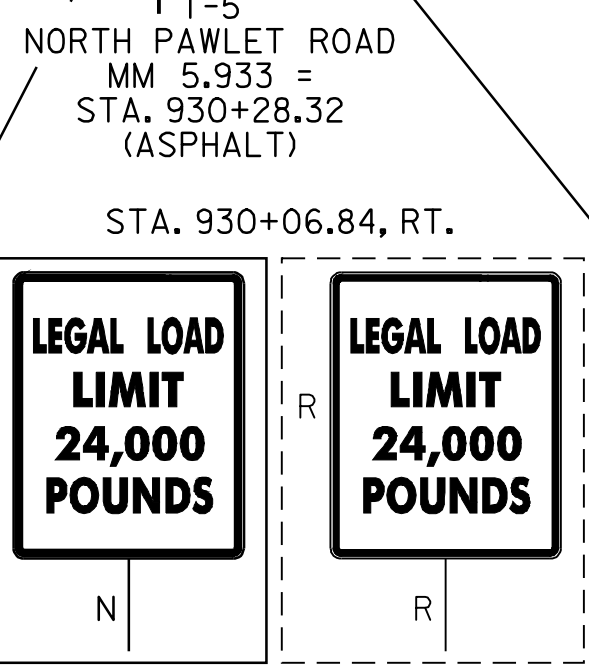
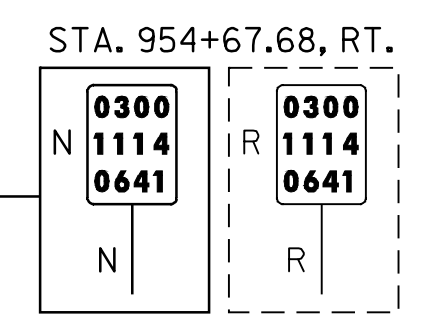
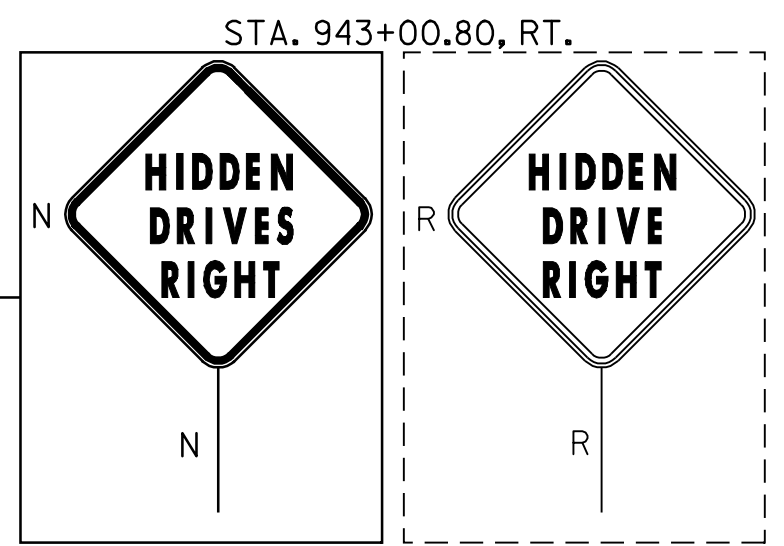
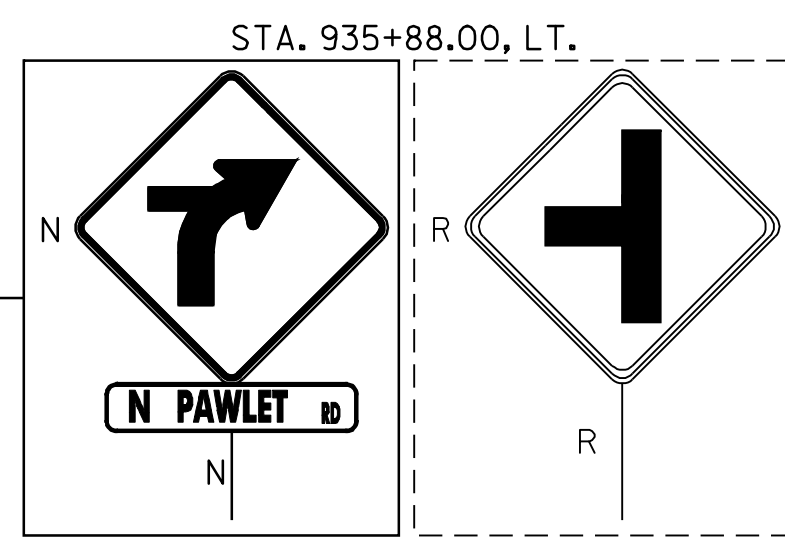
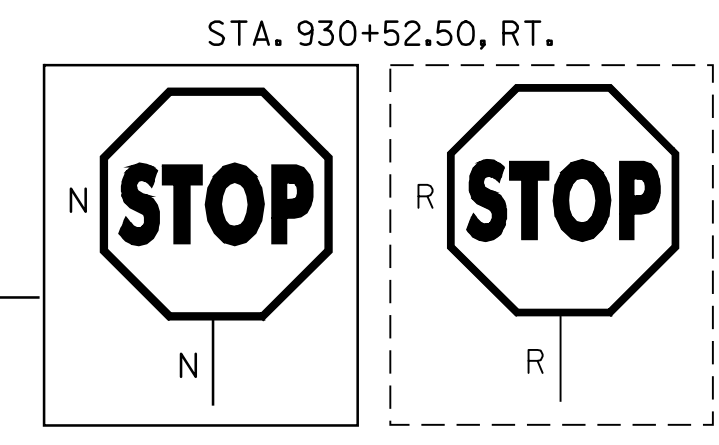
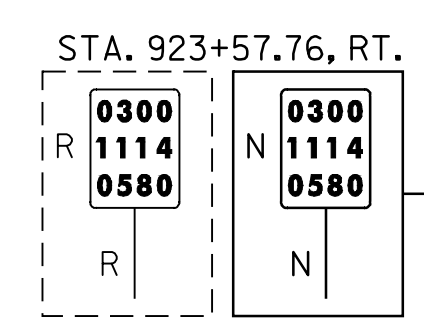
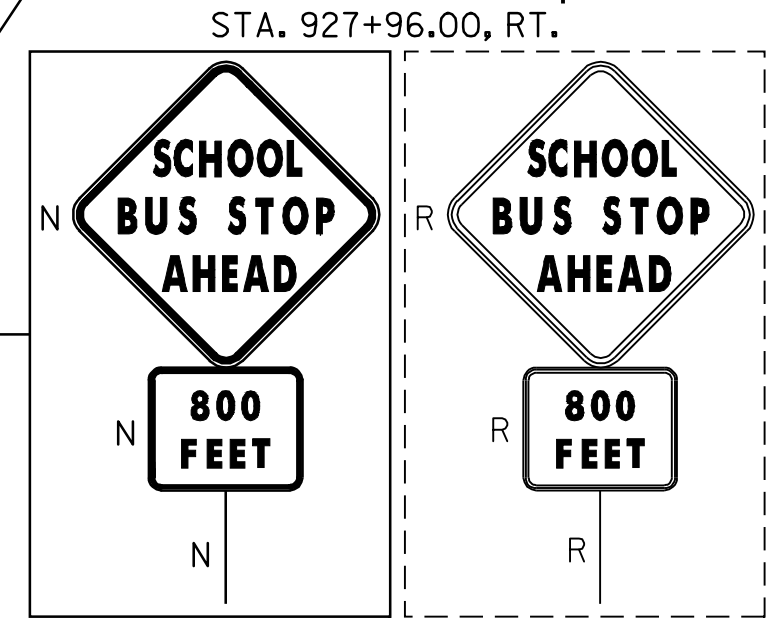
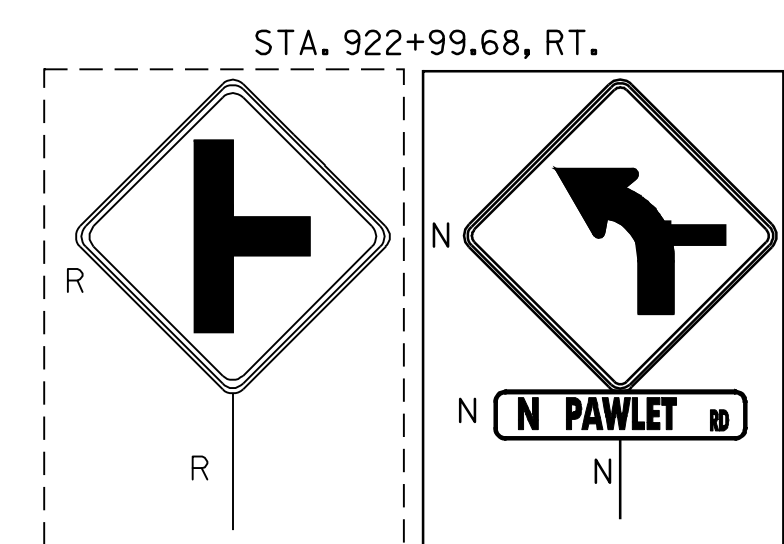
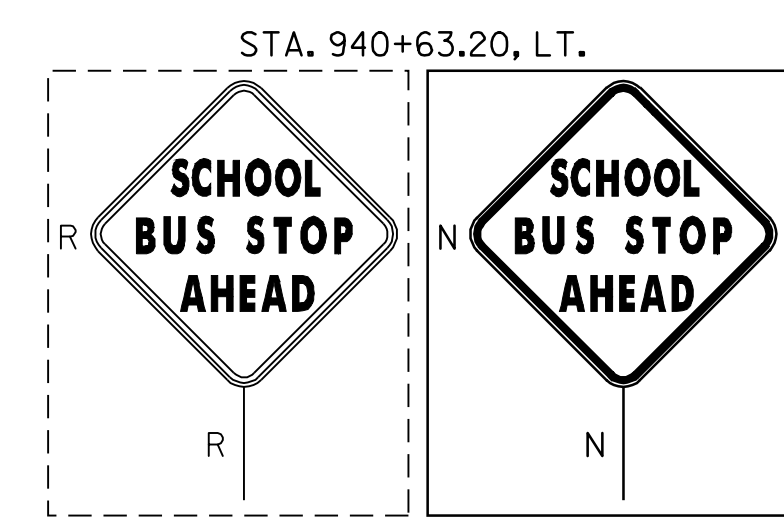

W/ REDUCED SPEED AHEAD
- REMOVED

W/MM 0300
1114
0597
- REMOVED

- SIGN LEGEND
- R= REMOVE
 - S= SALVAGE
 - N= NEW
 - RE= RETAIN
 - B-B= BACK TO BACK
 - EXISTING=
 - NEW=

900+00 - 960+00

PROJECT NAME: MANCHESTER-PAWLET	FILE NAME: STP_SIGN_PROJECT.dgn	PLOT DATE: 22-APR-2009 16:41
PROJECT NUMBER: STPG_SIGN (14)	PROJECT LEADER: N. AVERY	DRAWN BY: ROADWAY
DESIGNED BY: N. AVERY	CHECKED BY: A. GAMBLE	SHEET 19 OF 60
LAYOUT 16		