

SHIPMENT 1 PAKENGS: 5002B14 PRD: 5002B15 SHIPPERECT: 5002B16

BY: MK(reide) PLOTTED: 10/02/07 14:12:37

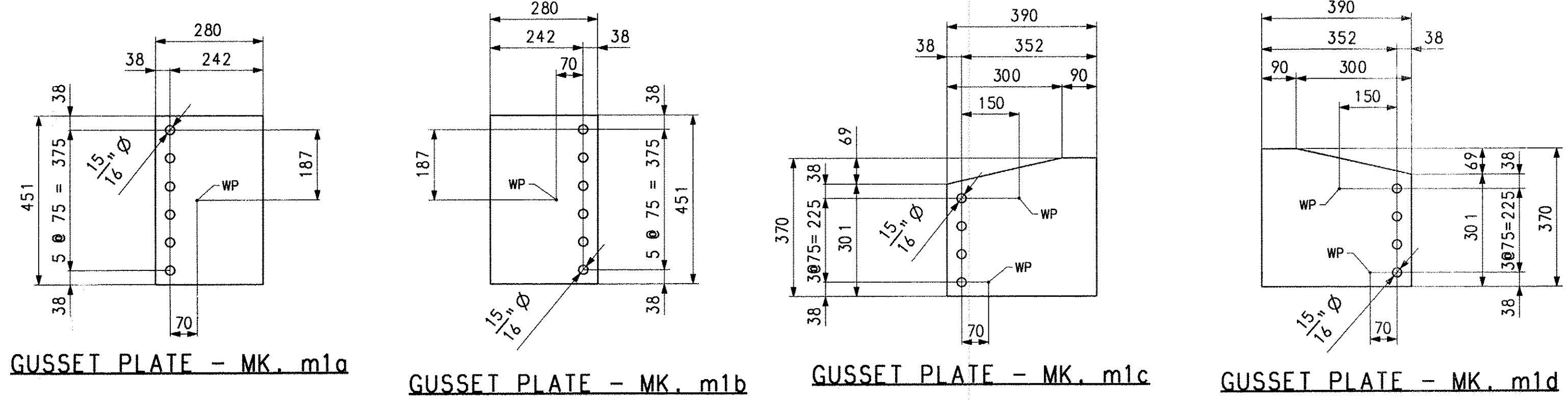

GUSSET PLATE - MK.m1a GUSSET PLATE - MK.m1b GUSSET PLATE - MK.m1c GUSSET PLATE - MK.m1d

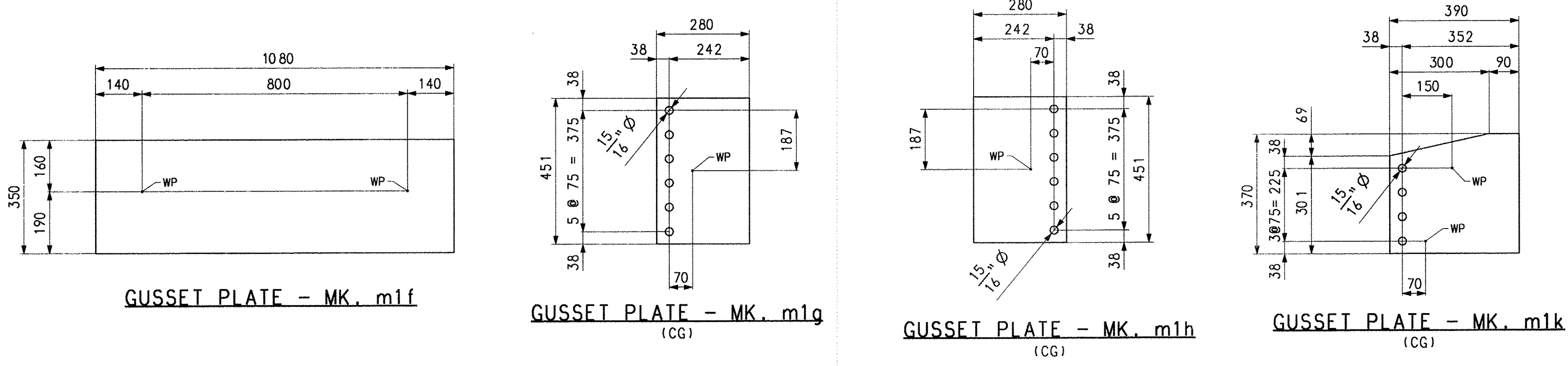

GUSSET PLATE - MK.m1f GUSSET PLATE - MK.m1g (CG) GUSSET PLATE - MK.m1h (CG) GUSSET PLATE - MK.m1k (CG)

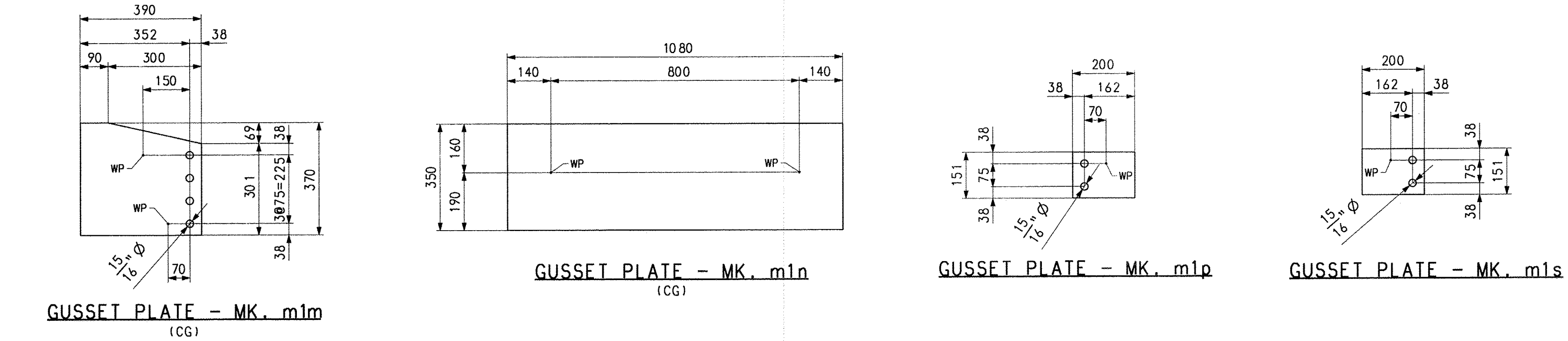

GUSSET PLATE - MK.m1m (CG) GUSSET PLATE - MK.m1n (CG) GUSSET PLATE - MK.m1p GUSSET PLATE - MK.m1s

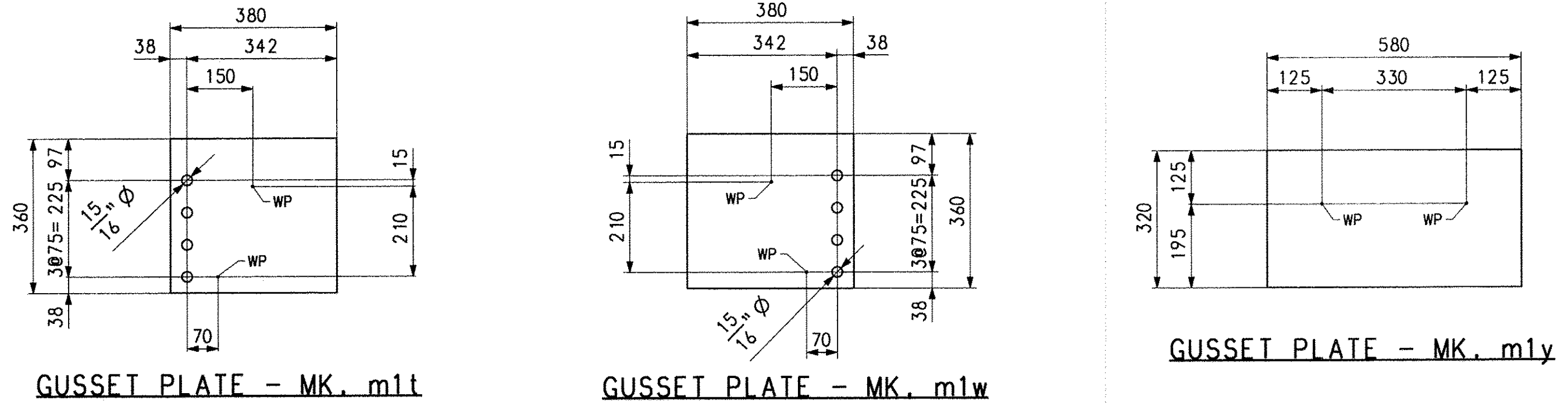

GUSSET PLATE - MK.m1t GUSSET PLATE - MK.m1w

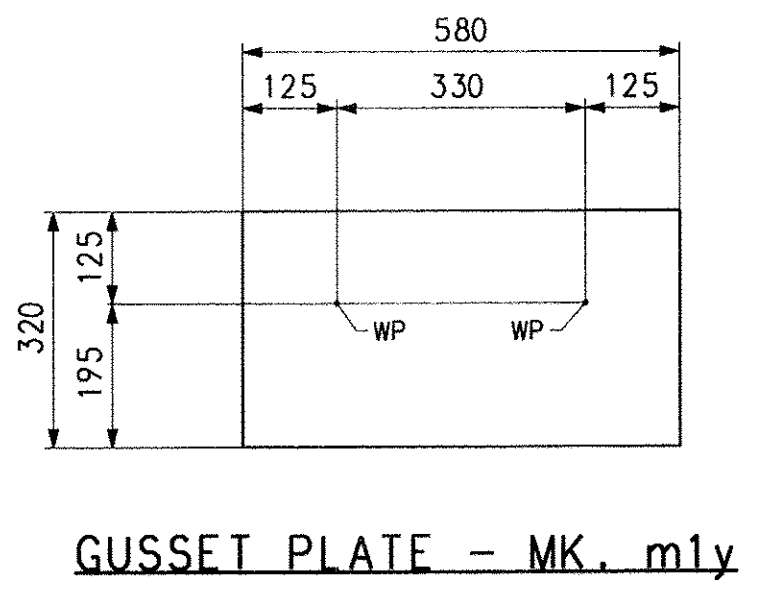

GUSSET PLATE - MK.m1y

NOTES:
FOR GENERAL SHOP NOTES, SEE DRAWING GN1.

BILL OF MATERIAL

QTY	MARK	COMMODITY	DESCRIPTION	LENGTH	SPEC	GRADE	TEST	REMARKS	ITEM	GROSS WEIGHT EA.	DEDUCTED WEIGHT EA.	NET WEIGHT EA.
1	m1a	PL	14.3 x 280	451	M270M	345W			11003	14.16		14.16
1	m1b	PL	14.3 x 280	451	M270M	345W			11003	14.16		14.16
1	m1c	PL	14.3 x 370	390	M270M	345W			11003	16.18		16.18
1	m1d	PL	14.3 x 370	390	M270M	345W			11003	16.18		16.18
1	m1e	PL	14.3 x 350	1080	M270M	345W			11003	42.39		42.39
1	m1g	PL	14.3 x 280	451	M270M	345W			11003	14.16		14.16
1	m1h	PL	14.3 x 280	451	M270M	345W			11003	14.16		14.16
1	m1k	PL	14.3 x 370	390	M270M	345W			11003	16.18		16.18
1	m1m	PL	14.3 x 370	390	M270M	345W			11003	16.18		16.18
1	m1n	PL	14.3 x 350	1080	M270M	345W			11003	42.39		42.39
10	m1p	PL	14.3 x 151	200	M270M	345W			11003	3.39		3.39
10	m1s	PL	14.3 x 151	200	M270M	345W			11003	3.39		3.39
10	m1t	PL	14.3 x 380	360	M270M	345W			11003	15.34		15.34
10	m1w	PL	14.3 x 380	360	M270M	345W			11003	15.34		15.34
10	m1y	PL	14.3 x 320	580	M270M	345W			11003	20.81		20.81

NO.	REVISION	BY	CHK'D	DATE
<p>HOLES: 15/16" Ø</p> <p>BOLTS: NONE</p> <p>COATING: NONE</p> <p>CODE(S): 63</p> <p>SCALE: N.T.S.</p> <p>STATE CONT. OR REF. NO.: AC NH 019-1153</p> <p>FED. AID PROJ. NO.:</p> <p>GENERAL CONTRACTOR: J.A. McDONALD, INC.</p> <p>HSSI PROJ. MGR: DEB KUPRES</p> <p>DRAWING MANAGER: BRITIGAN (IH)</p> <p>MADE BY: WBW</p> <p>CHK'D BY: CS</p> <p>DATE: 9-25-07</p> <p>SHIPMT: 2</p> <p>STATE: VT</p> <p>HSSI PROJECT NUMBER: S-1070 147</p> <p>HSSI STRUCT. ID: C</p> <p>DRAWING NUMBER: M1 OF M1</p>				