

GENERAL SHOP NOTES

SPECIFICATIONS:
 ALL MATERIAL AND WORKMANSHIP TO BE IN ACCORDANCE WITH THE STATE OF VERMONT, AGENCY OF TRANSPORTATION, STANDARD SPECIFICATIONS FOR CONSTRUCTION DATED 2006, AND ITS LATEST REVISIONS.

MATERIAL:
 UNLESS NOTED OTHERWISE, ALL STEEL TO BE AASHTO M270M GRADE 345W.
 (T) INDICATES ZONE 2 CHARPY V-NOTCH TESTING REQUIRED.

IN UNPAINTED AREAS SHOP BOLTS TO BE HIGH STRENGTH AASHTO M164 TYPE 3 (FRICTION) (RCT) WITH HEAVY HEX HEAD AND AASHTO M291 GRADE DH3 HEAVY HEX NUT, WITH ONE AASHTO M293 WEATHERING WASHER PER BOLT.
 IN PAINTED AREAS SHOP BOLTS TO BE HIGH STRENGTH AASHTO M164 TYPE 1 (FRICTION) (RCT) WITH HEAVY HEX HEAD AND AASHTO M291 GRADE DH HEAVY HEX NUT, WITH ONE AASHTO M293 WASHER PER BOLT, GALV. TO AASHTO M298, CLASS 50.
 (RCT) INDICATES ROTATIONAL CAPACITY TESTED BOLTS. DO NOT MIX NUTS, BOLTS AND WASHERS FROM DIFFERENT CONTAINERS UNLESS ALL NUTS, BOLTS AND WASHERS HAVE THE SAME LOT NUMBER.

SHOP PROCEDURE:
 ALL FLANGE AND WEB PLATE SPLICES TO BE MADE BEFORE FINAL FITTING AND WELDING INTO GIRDER.
 CAMBER TOLERANCE: -0 mm TO +19 mm
 ALL RE-ENTRANT CUTS TO HAVE 25 MIN. RADIUS.

BEARING AREA, AS NOTED ON GIRDER DETAILS, INDICATES AREA THAT MUST BE FLAT AND TRUE TO RECEIVE SOLE PLATE.
 USE LOW STRESS DIE STAMPS PLACED IN AN AREA NOT EXPOSED ON THE FINISHED STRUCTURE.

DDR INDICATES DIRECTION OF ROLLING.
 (CG) INDICATES CORNER GRINDING.
 CORNER GRINDING IS REQUIRED FOR ALL MAIN MEMBER FLANGE PLATES, FIELD SPlice PLATES, CROSSFRAMES AND CONNECTION PLATES AS WELL AS SECONDARY MEMBERS IN PAINTED AREAS.

INSPECTION:
 SHOP INSPECTION BY TO BE DETERMINED

WELDING:
 ALL WELDING IS TO CONFORM TO AWS D1.5-02.
 WELDING METHODS, PROCEDURES, AND MATERIALS SHALL COMPLY WITH THE SPECIFIC PROCEDURE DESIGNATED IN THE WELD SYMBOL TAIL.
 FOR WELDING STIFFENERS AND CONNECTION PLATES TO GIRDERS, SEE TYPICAL WELDING DETAIL.
 FOR WELDING CROSSFRAMES, SEE SECONDARY MEMBER WELDING DETAIL.
IDENTIFICATION OF HOLE PLACEMENT:
 UNLESS NOTED OTHERWISE, BOLT HOLES IN MATERIAL 16mm OR LESS IN THICKNESS MAY BE CNC (COMPUTER NUMERICALLY CONTROLLED) PUNCHED OR CNC DRILLED FULL SIZE UNASSEMBLED. ALL MATERIAL THICKER THAN 16mm IS TO BE DRILLED.

NON-DESTRUCTIVE TESTING:
 FLANGE AND WEB PLATE SPLICES TO BE RADIOGRAPHICALLY TESTED, AS CALLED FOR ON DRAWINGS PREFIXED "FS" AND "WC", BY H.S.S.I.

MAGNETIC PARTICLE INSPECTION IS REQUIRED ON AT LEAST 300 mm OF EVERY 3000 mm LENGTH OF FILLET WELDS AND 300 mm OF SUCH WELDS LESS THAN 3000 mm IN LENGTH ON GIRDER WEB TO FLANGE, CONNECTION PLATES AND BEARING STIFFENERS TO WEB AND FLANGE AND CROSSFRAME WELDS. TESTING PER THE YOKE METHOD, USING DC.

DT DRILLED TO TEMPLATE
 SINGLE PLY CONNECTION DRILLED FULL SIZE USING TEMPLATE WITH HARDENED BUSHINGS WHILE UNASSEMBLED.

NCD NUMERICALLY CONTROLLED DRILLING
 EACH PART IS DRILLED FULL SIZE USING A MACHINING CENTER, PORTABLE CNC DRILL OR DRILL LINE WHILE UNASSEMBLED.

CLEANING:
 ALL STEEL TO BE BLAST CLEANED TO SSPC-SP10 (NEAR WHITE), (ASTM D2200 GRADE SA 2-1/2), AFTER FABRICATION.
 BLAST CLEANING ANCHOR PROFILE TO BE FROM 38 TO 64 MICROMETERS DEEP IN PAINTED AREAS.

PAINTING:
 ALL STEEL TO BE PAINTED (UNLESS NOTED) WITHIN 3000mm FROM THE END OF THE GIRDERS AT ABUTMENT 2 WITH A 3 COAT SYSTEM AS FOLLOWS:
 PRIME COAT: CARBOZINC 859 (ORGANIC ZINC) WITH 75 TO 250 MICROMETERS D.F.T.
 INTER. COAT: CARBOGUARD 888 (EPOXY) WITH 75 TO 200 MICROMETERS D.F.T.
 FINISH COAT: CARBOthane 133 LH (POLYURETHANE) WITH 75 TO 150 MICROMETERS D.F.T.
 FINISH COAT COLOR TO BE DARK BROWN, FEDERAL STANDARD 595, COLOR #20059.
 PRIME COAT ONLY WITHIN 75 mm OF OPEN HOLES (150 MICROMETERS MAX. D.F.T.), UNLESS NOTED "P".
 PRIME COAT TO BE APPLIED WITHIN 8 HOURS AFTER BLAST CLEANING.
 STRIPE COAT ALL EDGES OF PLATES, ANGLES OR OTHER SHAPES WITH SHARP EDGES, BOLTS, AND NUTS PRIOR TO THE APPLICATION OF THE FULL PRIME COAT.
 TOP FLANGE OF GIRDERS, AS SHOWN IN "TYPICAL PAINT SECTION", SHALL RECEIVE A LIGHT RUST PREVENTIVE COAT OF PRIMER IN PAINTED AREAS, NOT TO EXCEED 38 MICROMETERS D.F.T.
 INTERMEDIATE AND FINISH COATS SHALL BE STAGGERED A MINIMUM OF 13 mm FROM THE FAYING SURFACES AND EACH OTHER.
 PAINT MANUFACTURER: THE CARBOLINE CO. ST. LOUIS, MO.

DRAWING REFERENCE:
 FLANGE SPLICES -PREFIXED "FS"
 WEB CAMBERS -PREFIXED "WC"
 GIRDER JOB STANDARDS -PREFIXED "X"
 CROSSFRAME JOB STDS. -PREFIXED "M"
 SHOP ASSEMBLY -PREFIXED "SA"
 HORIZONTAL CURVE -PREFIXED "HC"
 WELDING PROCEDURE -PREFIXED "WP"

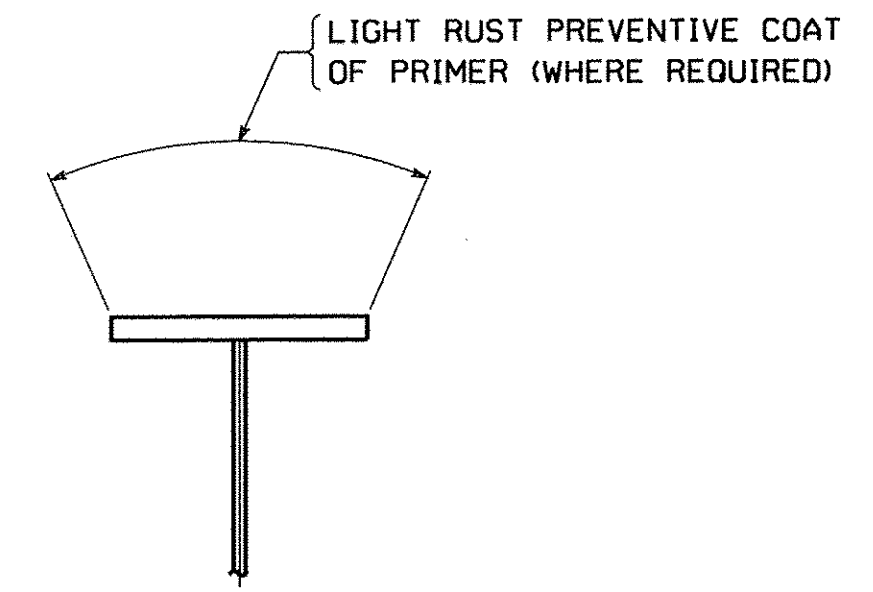

TYP. PAINT SECTION

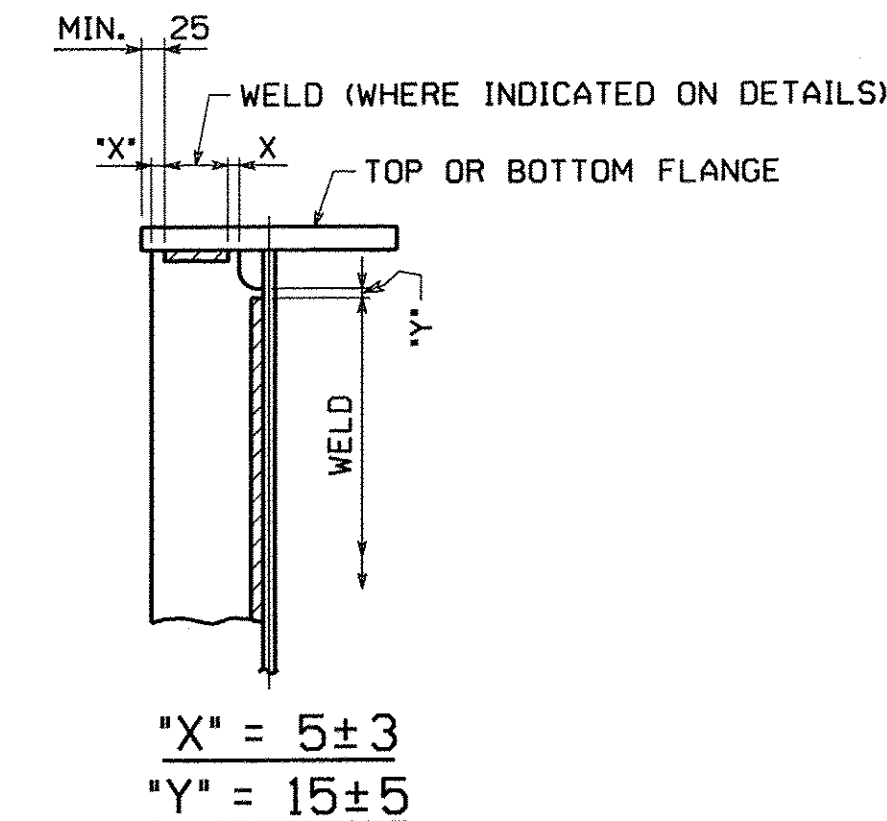

STIFFENER WELDING DETAIL
 (WELDS MUST STOP 25 mm MIN. FROM EDGE OF FLANGE)

ALL CROSSFRAME WELDS ARE TO BE TERMINATED FROM EDGE OF CUSSET PLATES, FILL PLATES OR ANGLES AS INDICATED.

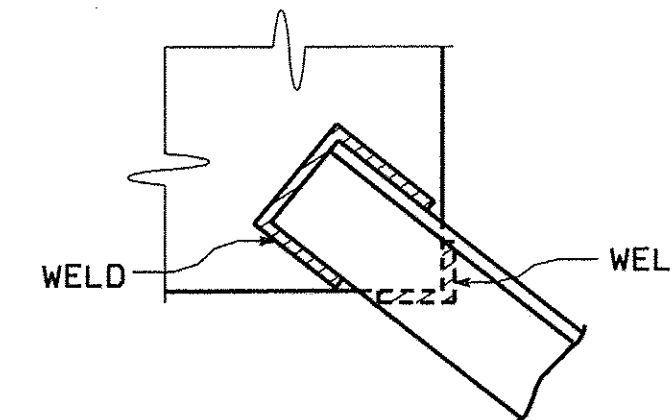

SECONDARY MEMBER WELDING DETAIL

NO.	REVISION	BY	CHK'D	DATE
HOLES				
BOLTS	GENERAL SHOP NOTES EAST ROAD OVER VT ROUTE 279 EAST ROAD STA. 1+148.400 TO STA. 1+220.200 TOWN OF BENNINGTON VERMONT, BRIDGE B11			
COATING	STATE OF VERMONT			
CODE(S)	AGENCY OF TRANSPORTATION			
SCALE	AC NH 019-1(53)	FED. AID PROJ. NO.		
N.T.S.	GENERAL CONTRACTOR J.A. McDONALD, INC.	HSSI PROJ. MGR	DEB KUPRES	
SHPMT	1	DRAWING MANAGER BRITIGAN (IH)	MADE BY KMA	CHK'D BY SJA DATE 8/24/07
STATE	VT	PROJECT NUMBER S-1070147	HSSI STRUCT. ID B	DRAWING NUMBER GN1 OF GN2