

SHIPMENT 1 PKMENG: XXXXXXXX PRD: XXXXXXXX SHIPPERECT: XXXXXXXX

PLOTTED: 10/01/07 09:29:56 BY: MK(re:ide)

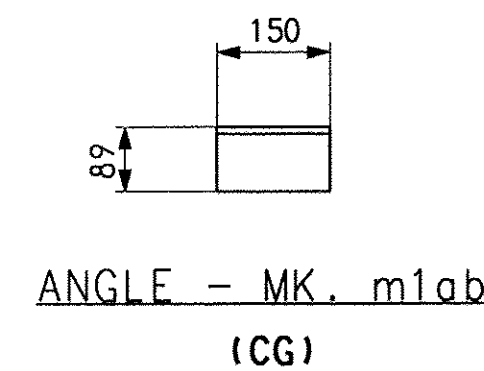
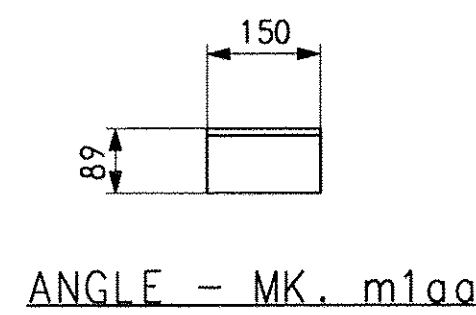
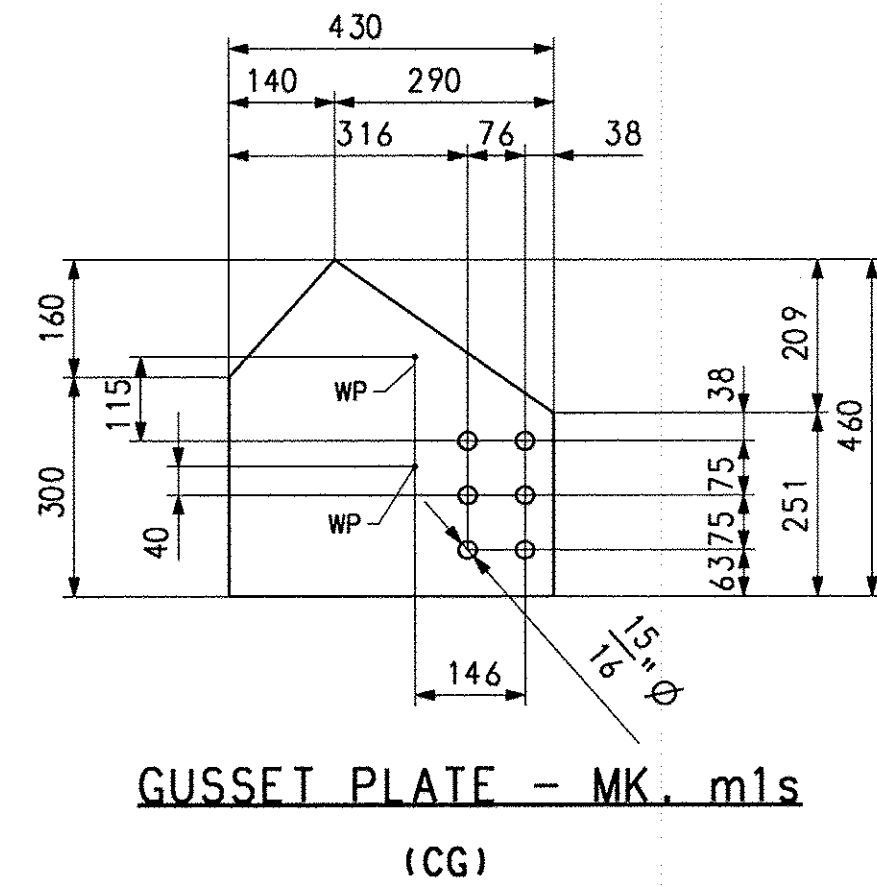
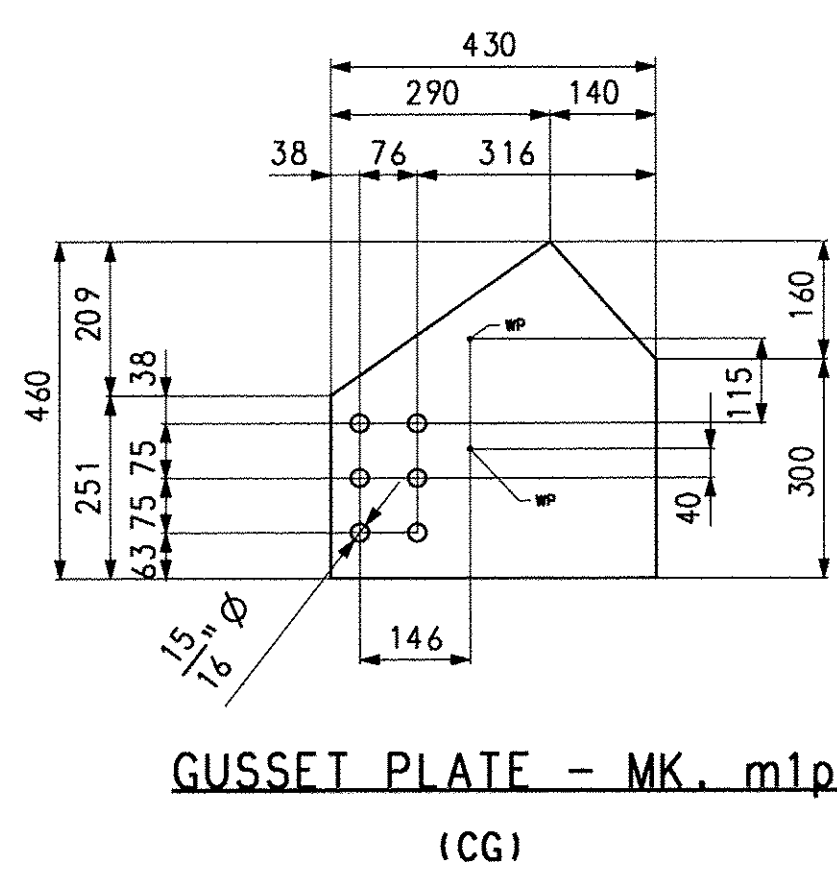
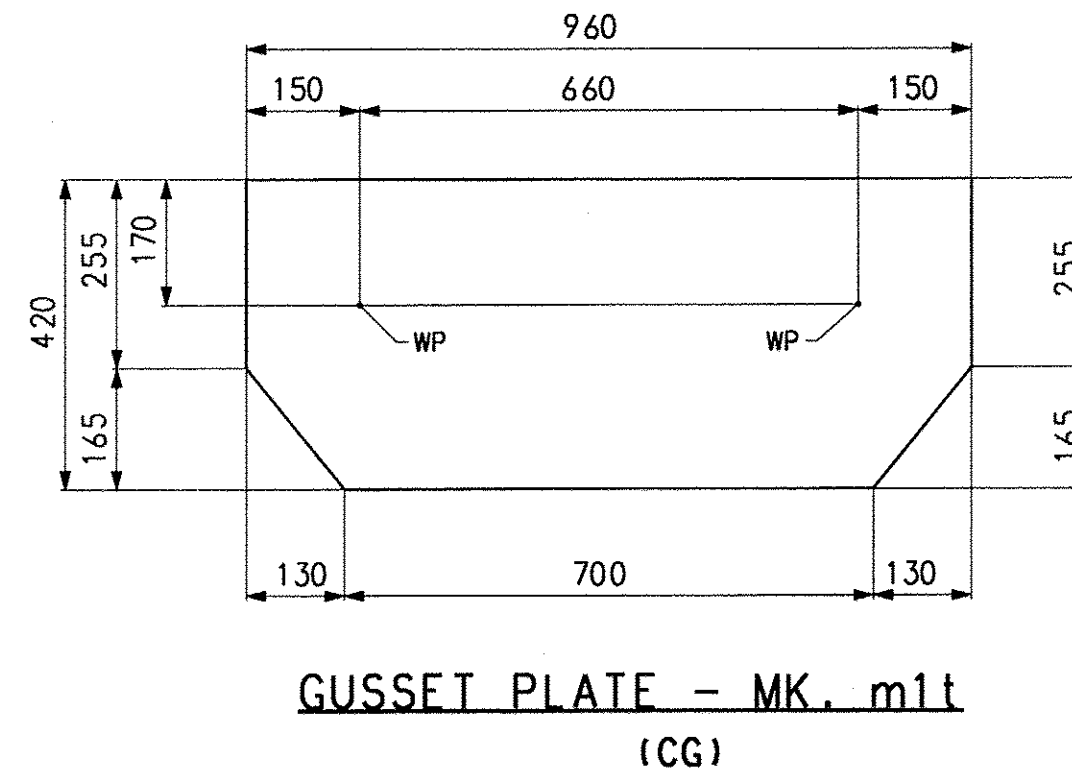
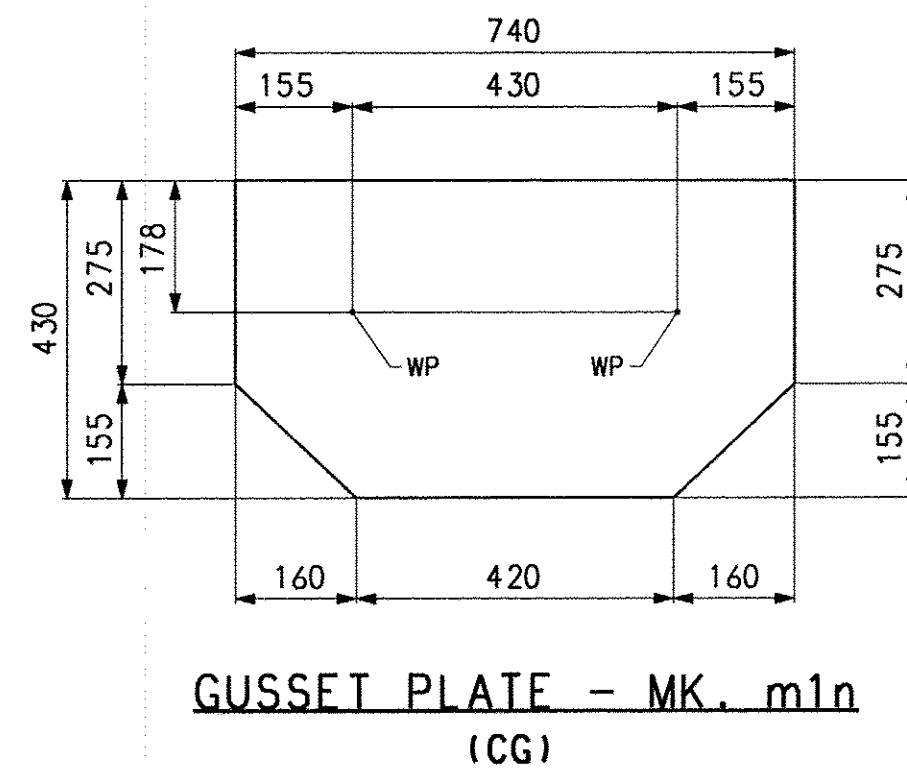
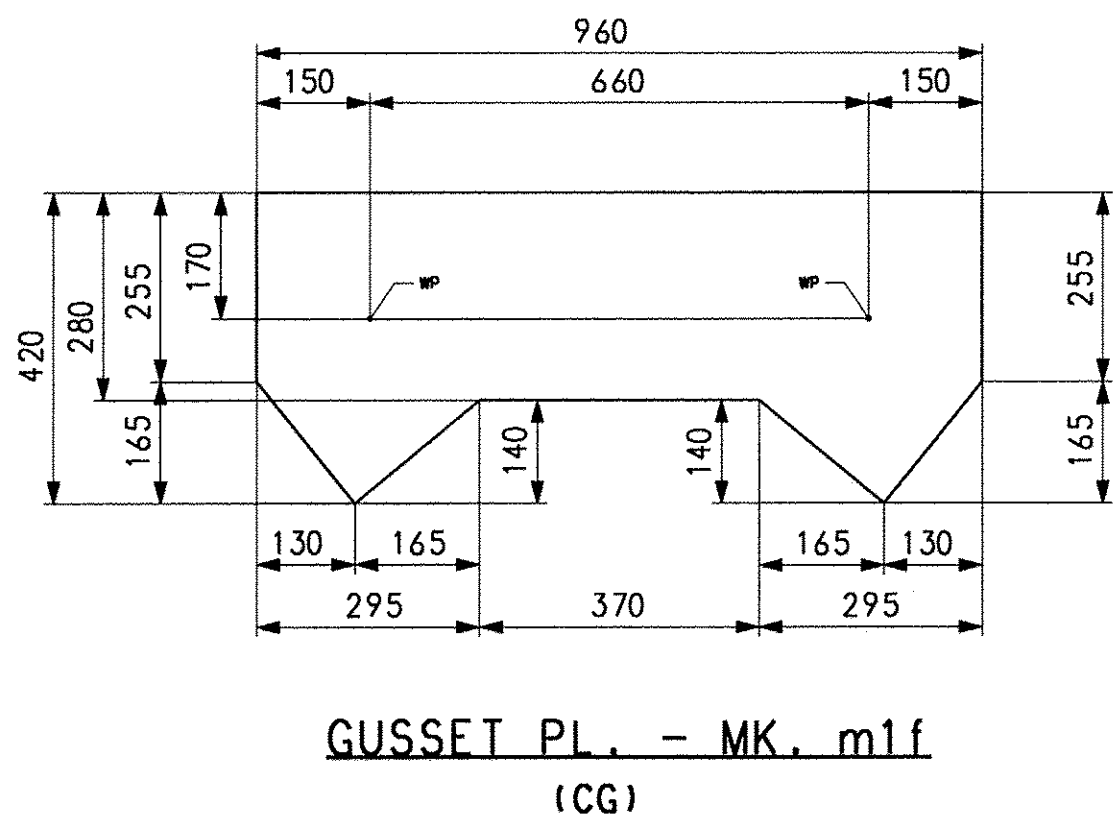
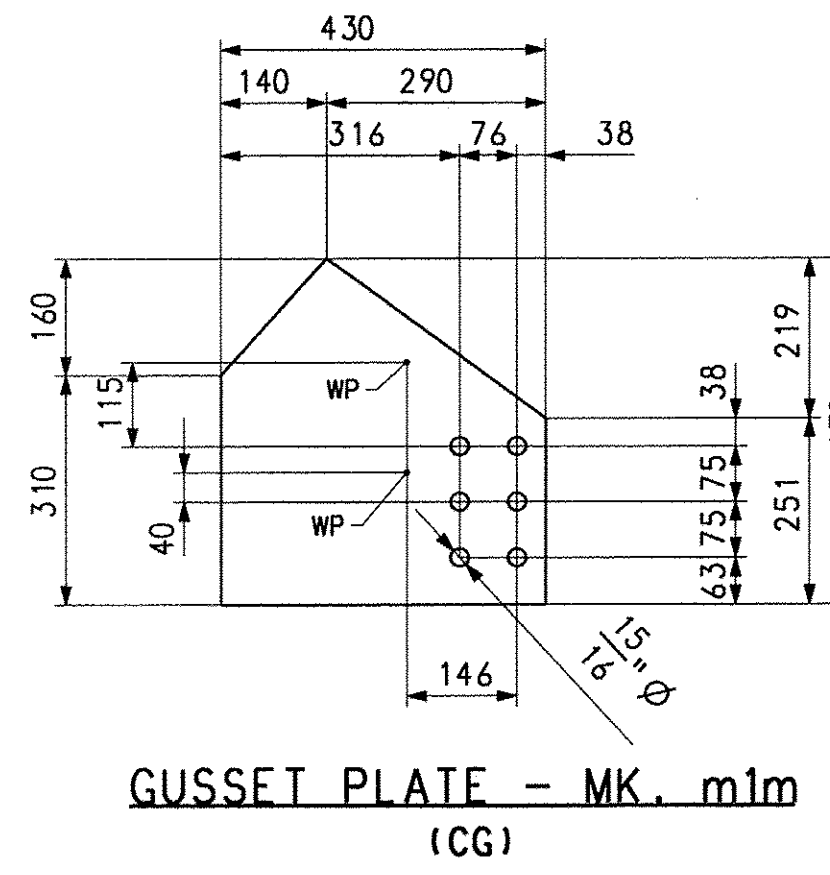
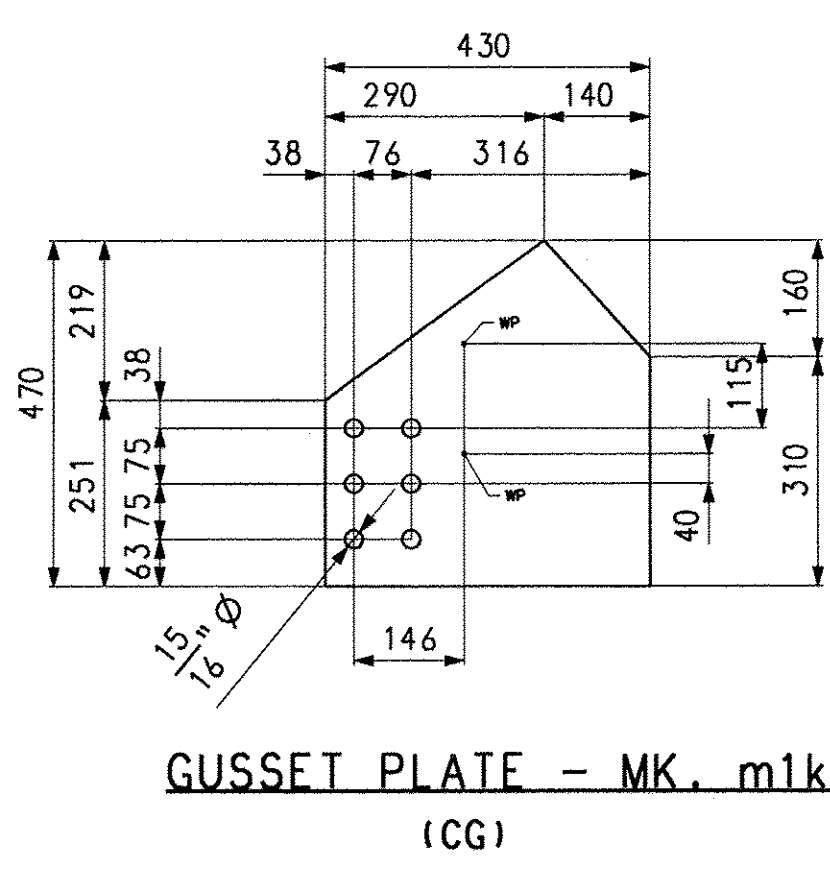
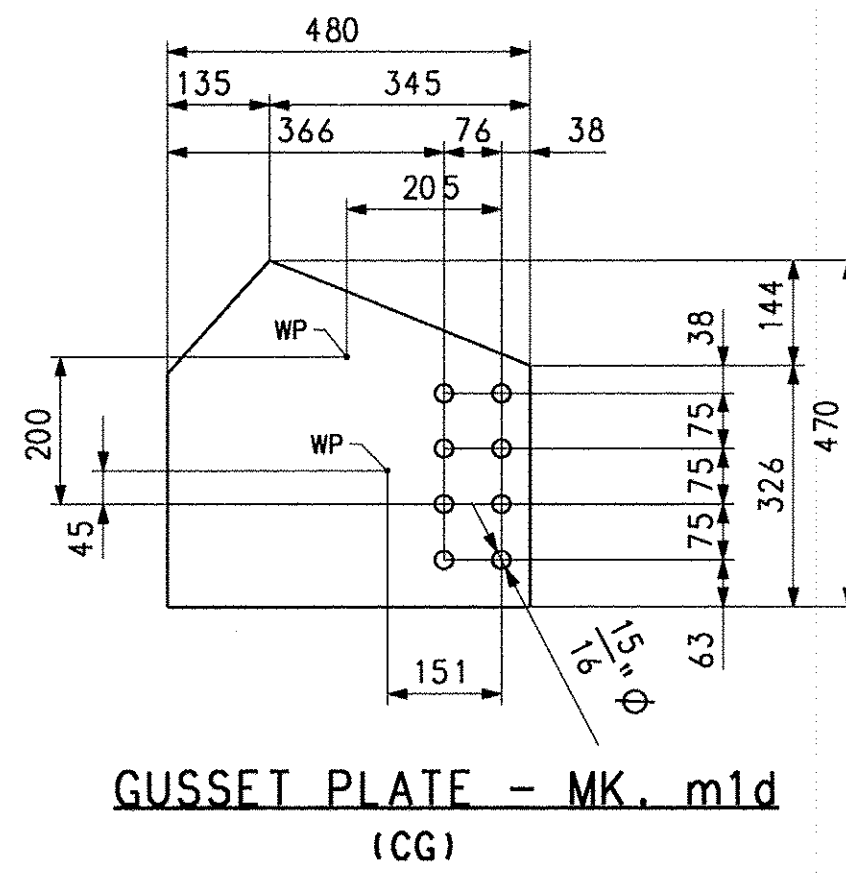
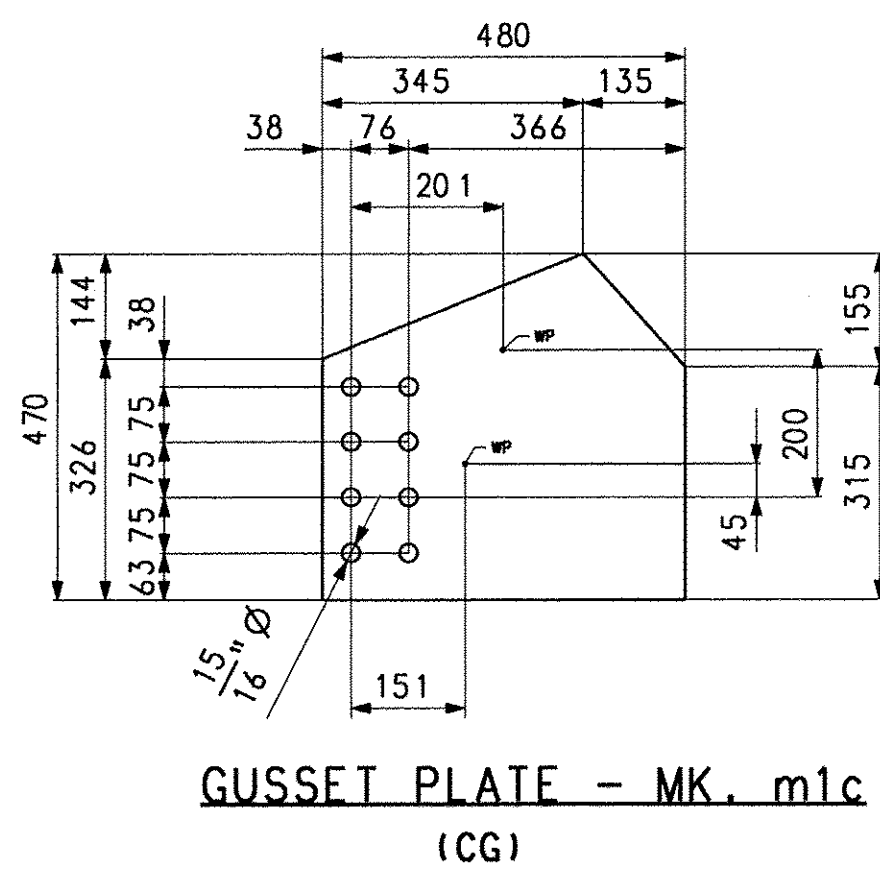
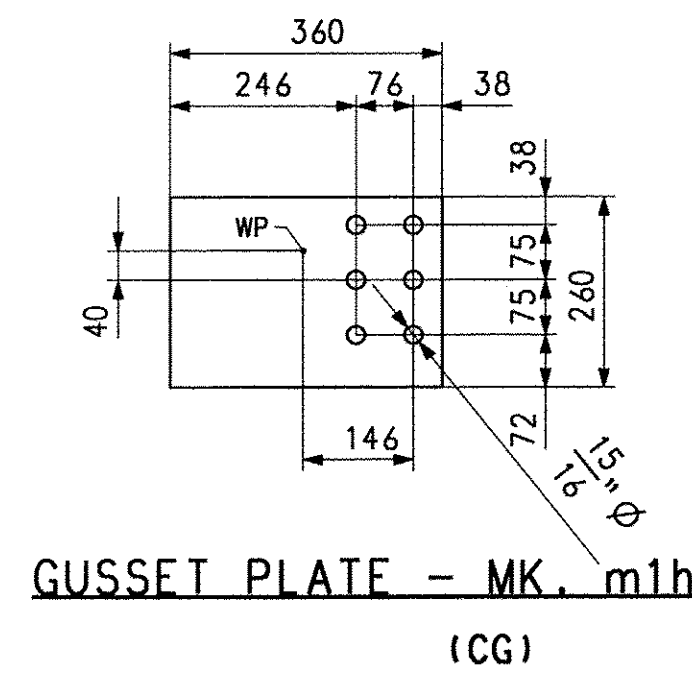
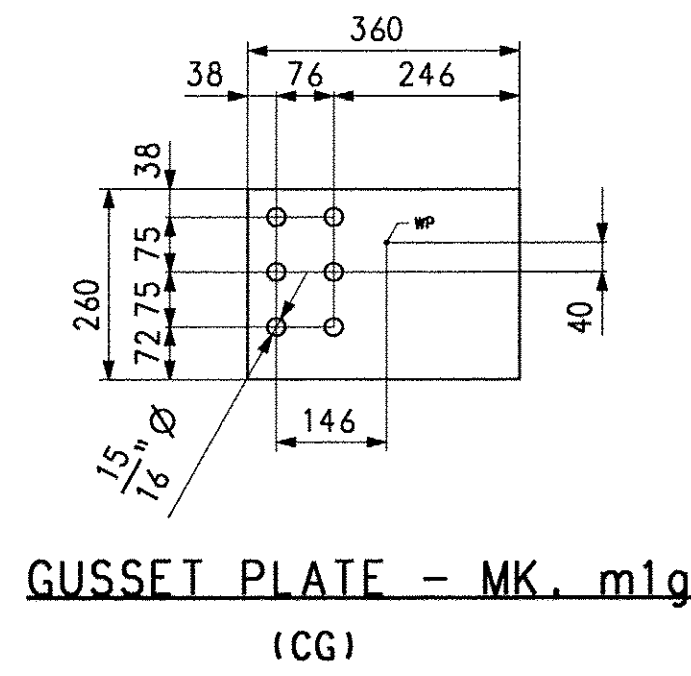
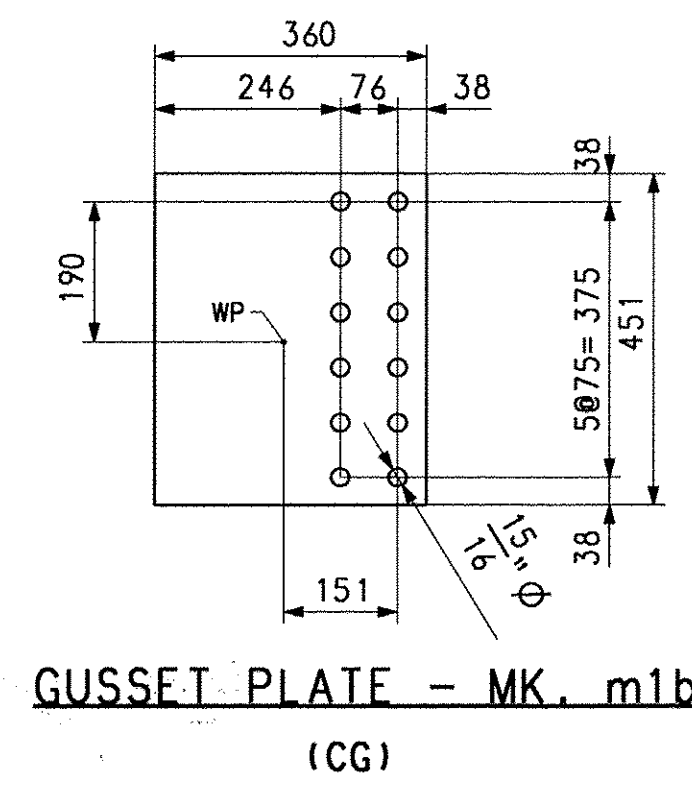
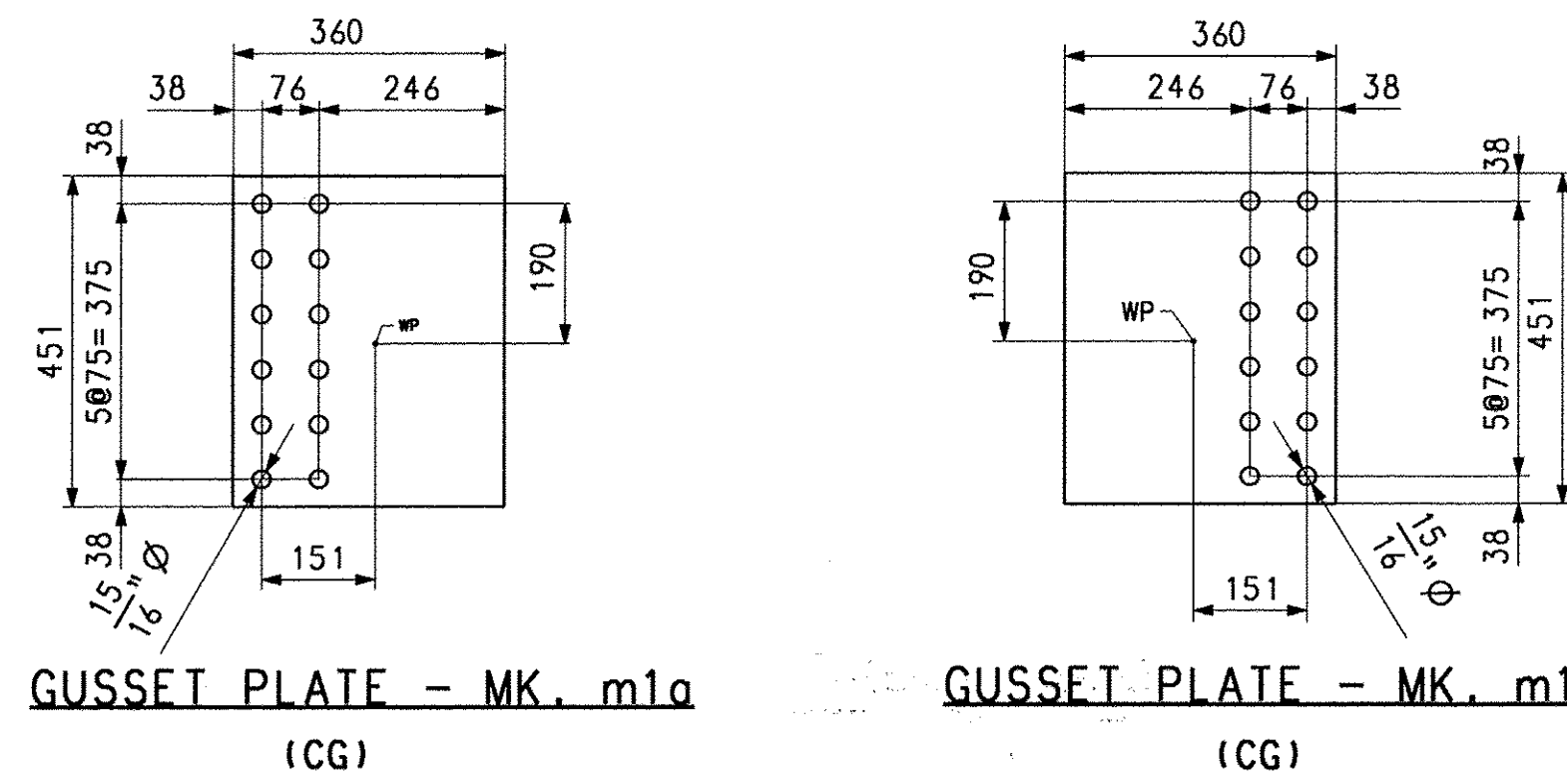

NOTE: FOR SHOP NOTES, SEE GN1.

**BILL OF MATERIAL**

QTY	MARK	COMMODITY	DESCRIPTION	LENGTH	SPEC	GRADE	TEST	REMARKS	ITEM	GROSS WEIGHT EA.	DEDUCTED WEIGHT EA.	NET WEIGHT EA.
6	m1a	PL	14.3 x 360	451	M270M	345W	T		11003	18.21	0.00	18.21
6	m1b	PL	14.3 x 360	451	M270M	345W	T		11003	18.21	0.00	18.21
6	m1c	PL	14.3 x 470	480	M270M	345W	T		11003	25.30	0.00	25.30
6	m1d	PL	14.3 x 470	480	M270M	345W	T		11003	25.30	0.00	25.30
4	m1e	PL	14.3 x 420	960	M270M	345W	T		11003	45.26	0.00	45.26
30	m1g	PL	14.3 x 260	360	M270M	345W	T		11003	10.50	0.00	10.50
30	m1h	PL	14.3 x 260	360	M270M	345W	T		11003	10.50	0.00	10.50
27	m1k	PL	14.3 x 430	470	M270M	345W	T		11003	22.66	0.00	22.66
27	m1m	PL	14.3 x 430	470	M270M	345W	T		11003	22.66	0.00	22.66
30	m1n	PL	14.3 x 430	740	M270M	345W	T		11003	35.68	0.00	35.68
3	m1p	PL	14.3 x 430	480	M270M	345W	T		11003	22.18	0.00	22.18
3	m1s	PL	14.3 x 430	480	M270M	345W	T		11003	22.18	0.00	22.18
2	m1t	PL	14.3 x 420	960	M270M	345W	T		11003	45.26	0.00	45.26
88	m1aa	L	89 x 89	9.5	150	M270M	345W		11004	1.90	0.00	1.90
4	m1ab	L	89 x 89	9.5	150	M270M	345W		11004	1.90	0.00	1.90

NO.	REVISION	BY	CHK'D	DATE
<b>HIGH STEEL STRUCTURES INC.</b> An ISO 9001:2000 Certified Company An Affiliate of High Industries Inc. 1915 Old Philadelphia Pike Lancaster, PA 17605-0008 Phone (717) 299-5211 www.highsteel.com				
CROSSFRAME JOB STANDARDS				
EAST ROAD OVER VT ROUTE 279				
EAST ROAD STA. 1+148.400 TO STA. 1+220.200				
TOWN OF BENNINGTON VERMONT, BRIDGE B11				
STATE OF VERMONT				
AGENCY OF TRANSPORTATION				
STATE CONT. OR REF. NO. AC NH 019-11531				
SCALE N.T.S.				
GENERAL CONTRACTOR		J.A. McDONALD, INC.		HSSI PROJ. MGR
DEB KUPRES		HSSI PROJ. MGR		
SHPMNT	1	DRAWING MANAGER	BRITIGAN (IH)	MADE BY
STATE	VT	HSSI PROJECT NUMBER	S-1070147	HSSI STRUCT. ID
SSL		CHK'D BY	CS	DATE
9-18-07		M1 OF M1		