

TYPICAL SECTION

NOTE: FOR DIMENSIONS SEE SHEETS BR1M & BR2M.

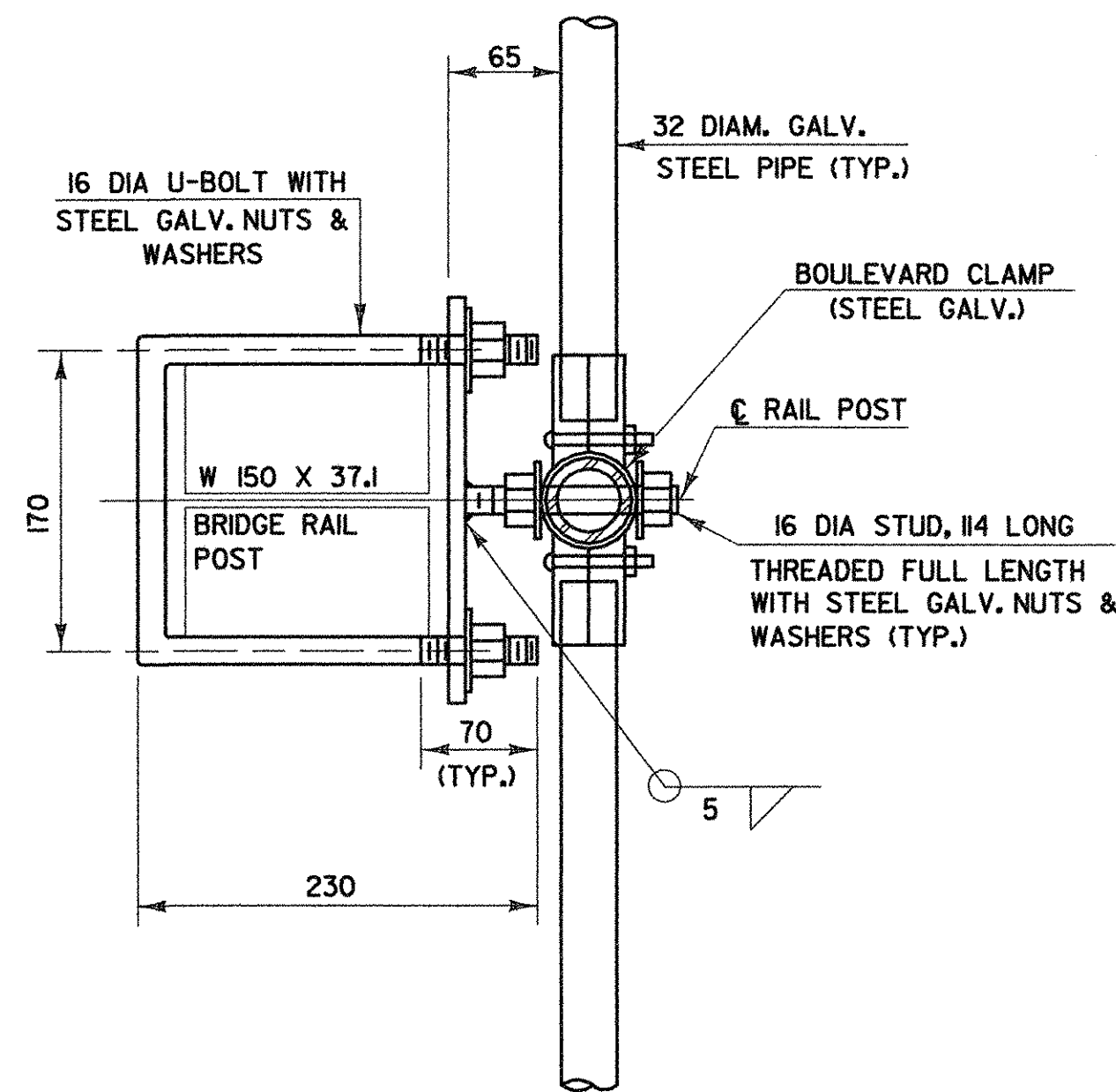

SECTION A-A

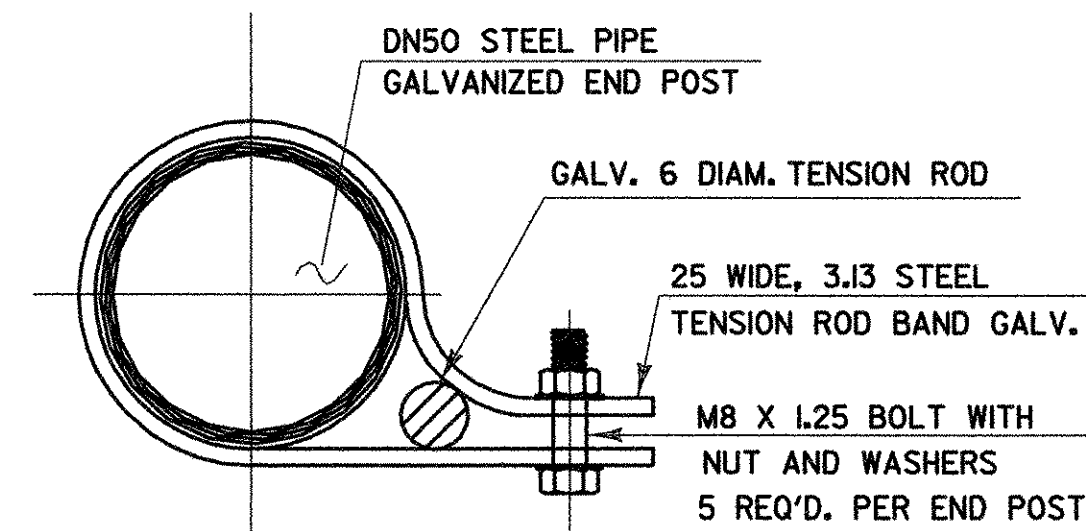

TENSION ROD BAND

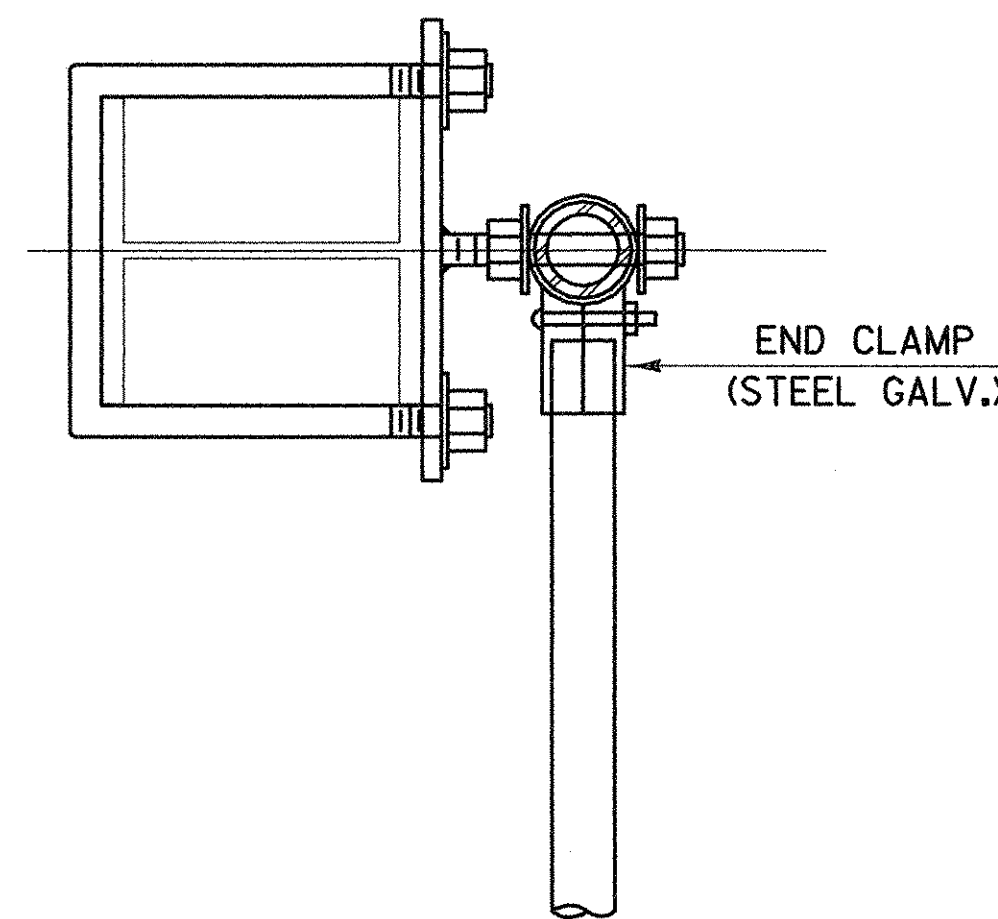

PLAN VIEW AT END POST

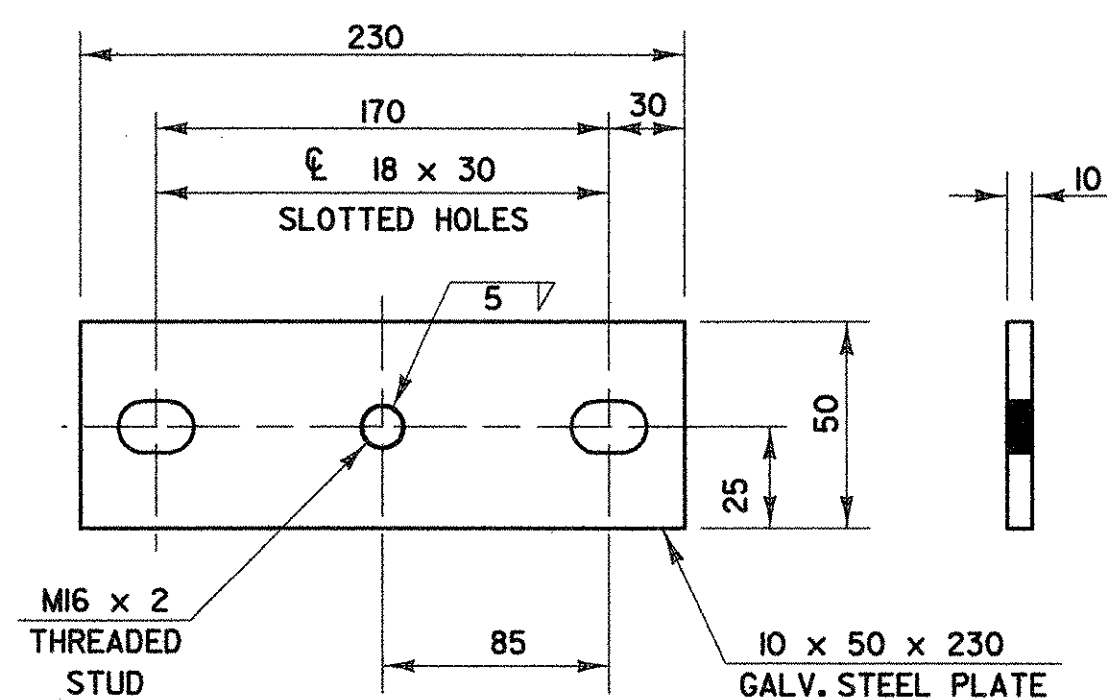
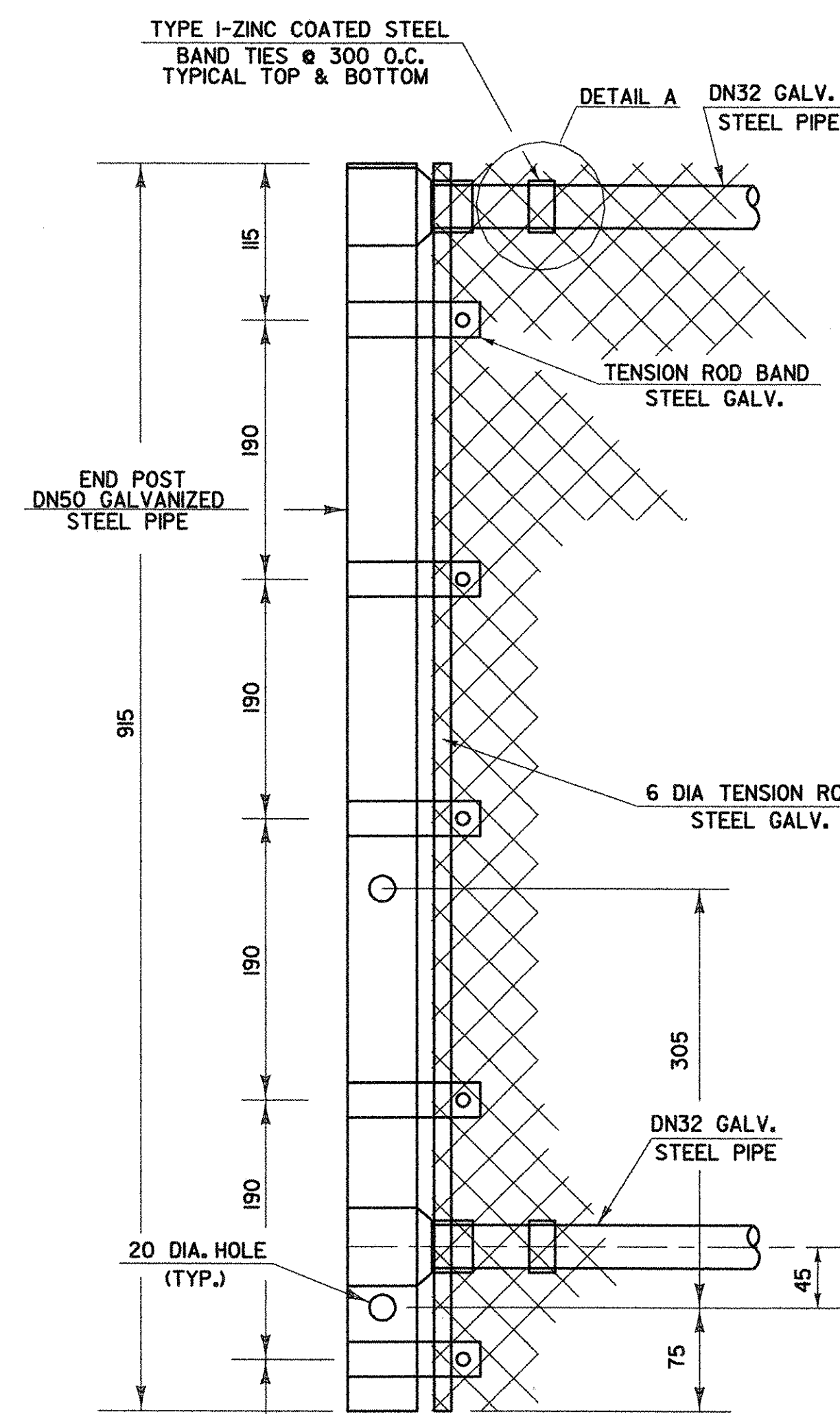
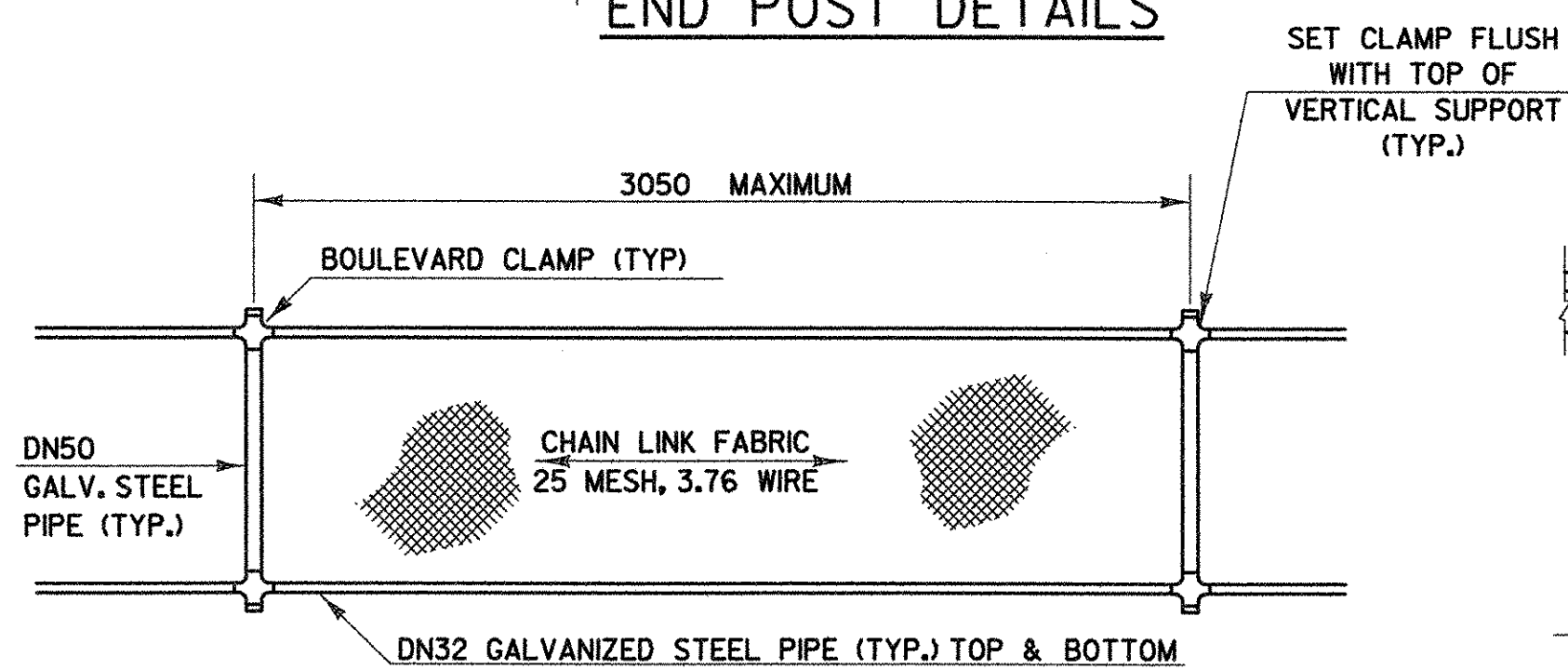

PLATE DETAILS



END POST DETAILS



ELEVATION SNOW BARRIER

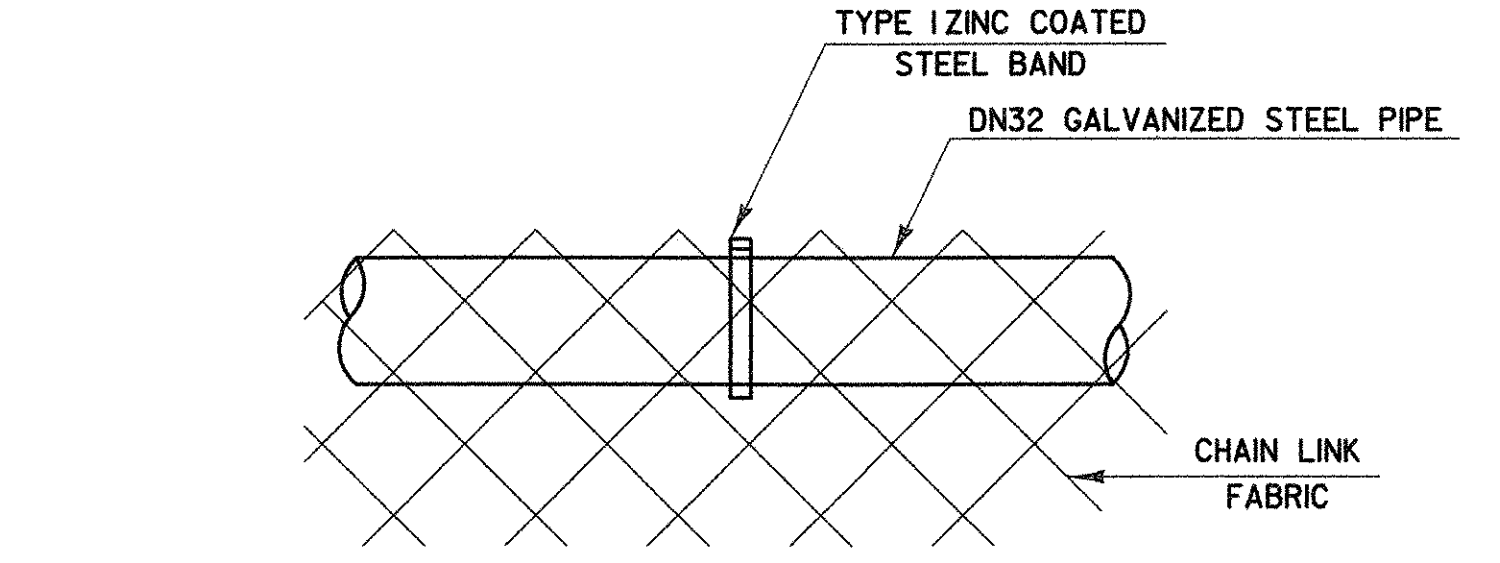

DETAIL A

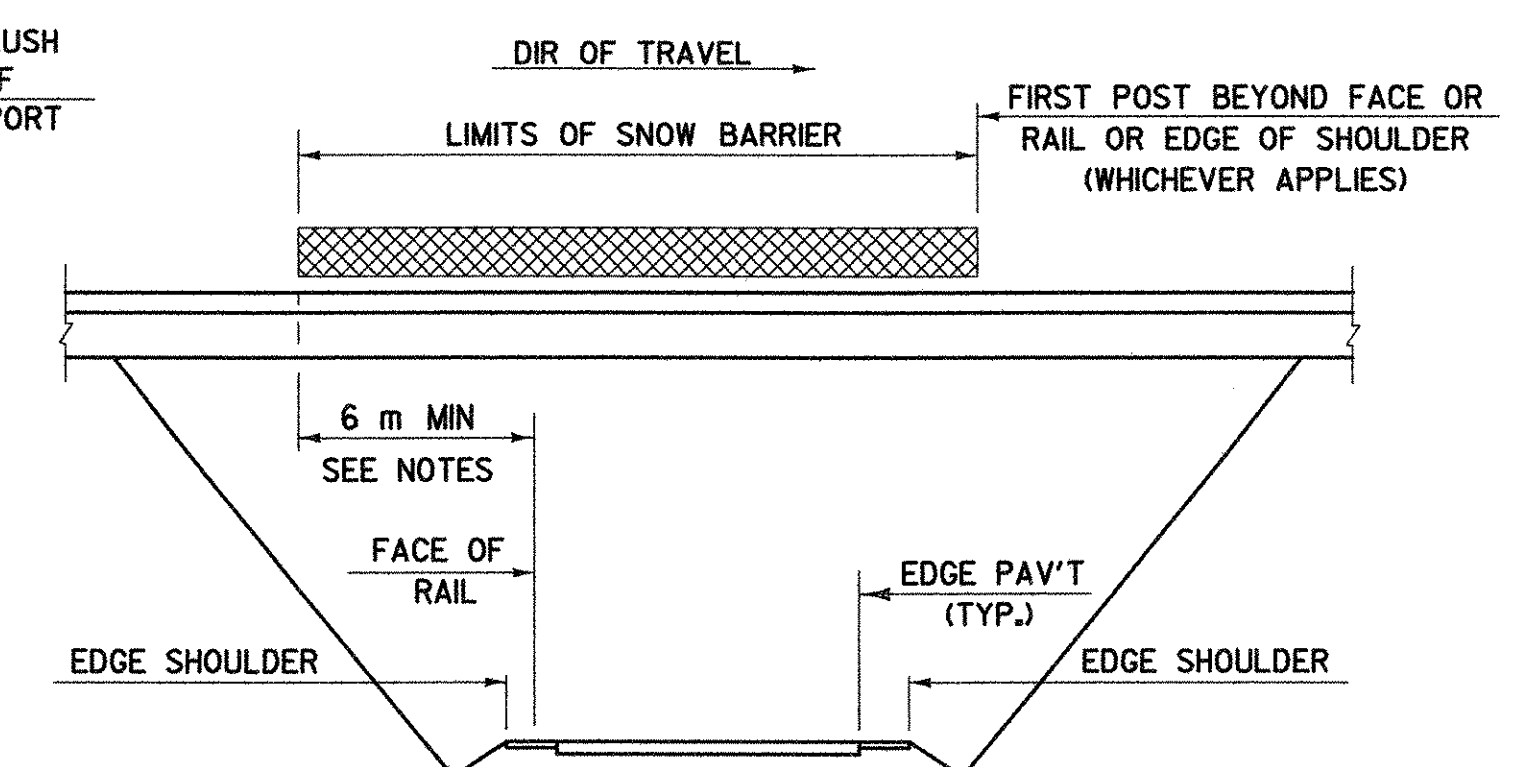

SCHEMATIC SNOW BARRIER LIMITS

- NOTES**
1. THREADS OF STUDS AND U-BOLTS TO BE M16 x 2.
 2. ALL CONNECTION PLATES TO BE GALVANIZED AFTER FABRICATION.
 3. DN 32 PIPE LENGTH SHALL BE FIELD CUT TO FIT POST SPACING.
 4. CHAIN LINK FABRIC TO BE KNUCKLED TOP AND BOTTOM.
 5. ALL BOLTS, THREADED STUDS AND WASHERS SHALL CONFORM TO THE SPECIFICATIONS FOR AASHTO M164M, TYPE 1. NUTS SHALL CONFORM TO AASHTO M291M.
 6. ALL STEEL PLATES SHALL CONFORM TO THE SPECIFICATION FOR AASHTO M270/M270M, GRADE 250.
 7. ALL GALVANIZING SHALL CONFORM TO THE REQUIREMENTS OF AASHTO M-181 WITH HARDWARE AND FITTINGS CONFORMING TO THE REQUIREMENTS OF AASHTO M-111 OR AASHTO M-232 WHICHEVER IS APPLICABLE. ALL BOLTS, NUTS AND WASHERS SHALL BE EITHER HOT-DIP GALVANIZED IN ACCORDANCE WITH THE ABOVE AASHTO REQUIREMENTS OR MECHANICALLY GALVANIZED USING A MECHANICALLY DEPOSITED PROCESS CONFORMING TO THE REQUIREMENTS OF AASHTO M-298, CLASS 110.
 8. GALVANIZED CHAIN-LINK FABRIC SHALL BE TYPE I (ZINC) CLASS D AS SPECIFIED IN AASHTO M181.
 9. SNOW BARRIER SHALL BEGIN AT THE BRIDGE RAIL POST WHICH WILL PROVIDE A MINIMUM DISTANCE OF 6m (AS SHOWN) OR AS DIRECTED BY THE ENGINEER.
 10. ALL DN (I.E. DIAMETER NOMINAL) REFERENCES TO GALVANIZED STEEL PIPE SHALL REFER TO THE NOMINAL PIPE SIZE.
 11. ALL POSTS, RAILS AND HARDWARE SHALL BE ZINC COATED AND CONFORM TO THE REQUIREMENTS OF AASHTO M181, GRADE 1 OR GRADE 2. TYPE IZINC COATED



DETAIL
BR4M

SNOW FENCE FOR
BRIDGE RAILING -
N.E.T.C.2 RAIL

NOTE: ALL DIMENSIONS ARE IN MILLIMETERS (mm) EXCEPT WHERE NOTED.

Town Of	BENNINGTON	Bridge No.	B12
Highway No.	VT RTE 279	Log Sta.	
		Surv. Sta.	
VT ROUTE 279 OVER FURNACE BROOK			
SNOW FENCE FOR BRIDGE RAILING - NETC 2 RAIL			
Designed By	VAOT	Drawn By	VAOT
Checked By	VAOT	Bridge Design Supervisor	VAOT
PROJECT	BENNINGTON	PROJECT NO.	AC NH F019-K(53)
TVGA CAD Drawing No.	FBAppGR4.dgn	Date	04/10/2007
Bridge Sheet No.	BR543	Sheet	235 of 577