

**LEGEND**

- AMC.OI(9) DECIDUOUS SHRUB GROUPING WITH PLANT TYPE AND (QUANTITY)
- AR.OI(3) DECIDUOUS TREE GROUPING WITH PLANT TYPE AND (QUANTITY)
- AC.OI(4) EVERGREEN TREE GROUPING WITH PLANT TYPE AND (QUANTITY)
- EXISTING DECIDUOUS TREE
- EXISTING EVERGREEN TREE
- TOE OF SLOPE
- LIMIT OF CUT
- APPROXIMATE ULTIMATE TOE OF SLOPE
- APPROXIMATE ULTIMATE LIMIT OF CUT
- TREELINE
- R.O.W.

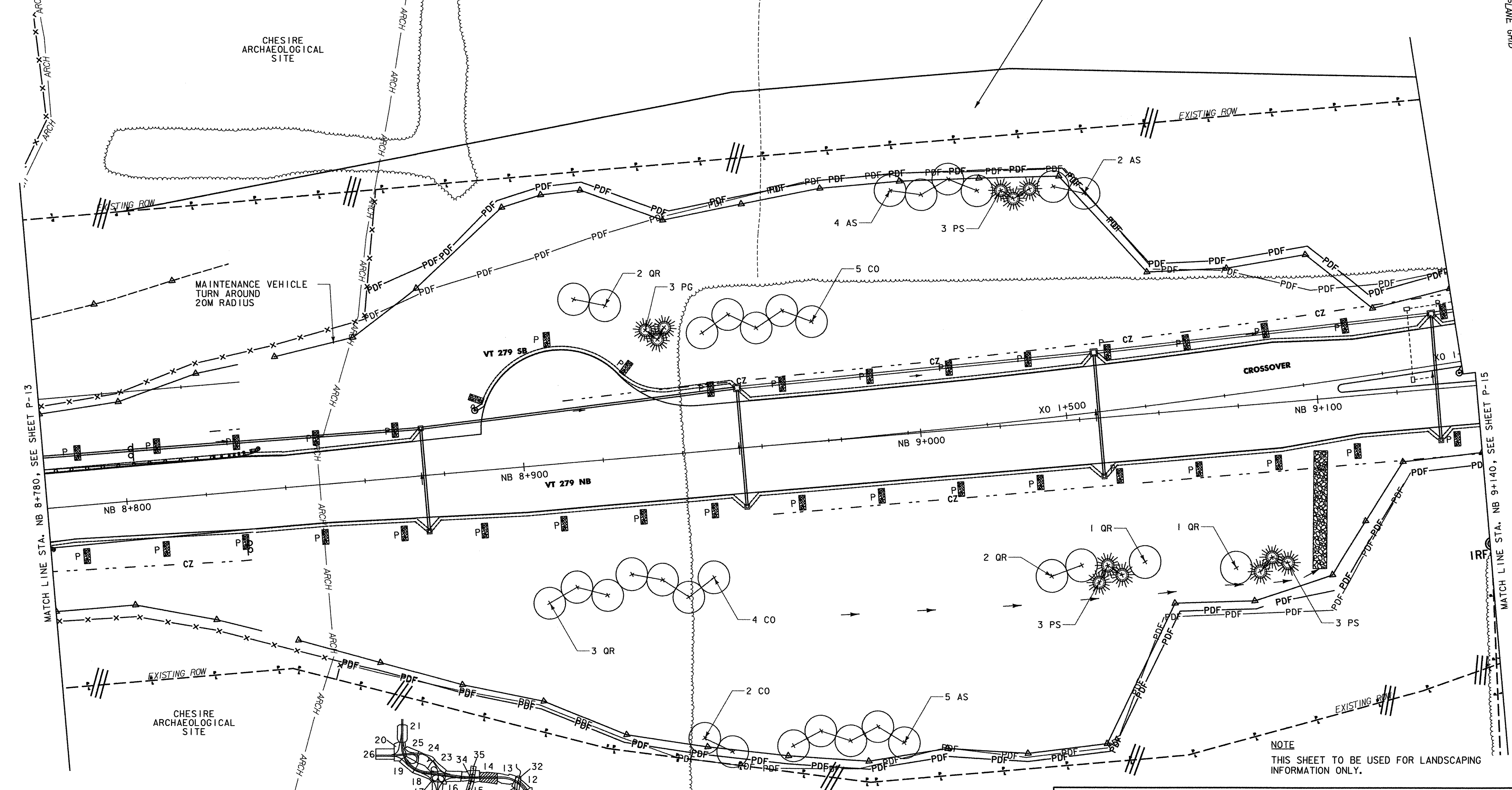

MATCH LINE STA. NB 8+780, SEE SHEET P-13

MATCH LINE STA. NB 9+140, SEE SHEET P-15

NOTE:  
1. STA 8+920 - 8+970, RT PDF WILL BE LOCATED WITHIN EXISTING ROW.

KEY MAP

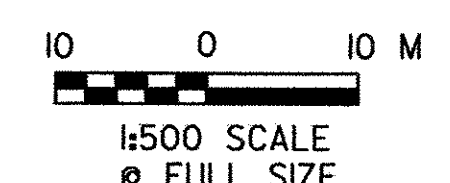
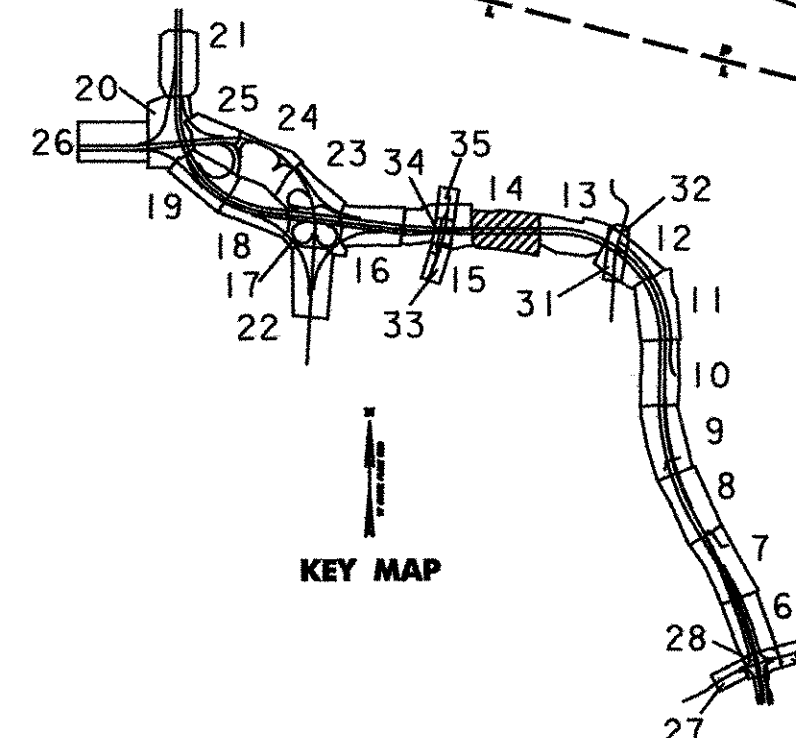

NOTE  
THIS SHEET TO BE USED FOR LANDSCAPING INFORMATION ONLY.

<b>VERMONT AGENCY OF TRANSPORTATION</b>	
	PROJECT NAME: BENNINGTON - NORTH
	PROJECT NUMBER: BENNINGTON AC NH 019-1(53)
	FILE NAME: ...R13463PC\DGN\P14.dwg
	DESIGN SUPERVISOR: J. BENSON
DESIGNED BY: J. STEELE/C. BRODIE	PLOT DATE: 05/18/2007
LANDSCAPE PLAN L-4	DRAWN BY: E. SMALL
	CHECKED BY: J. STEELE
	SHEET 188 OF 577

\\server\projects\13463PC\001\14.dwg