

STATE OF VERMONT
AGENCY OF TRANSPORTATION

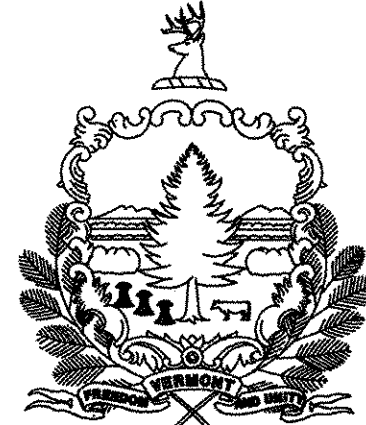

PROPOSED IMPROVEMENT
TOWN OF BENNINGTON
COUNTY OF BENNINGTON
WWII VETERANS MEMORIAL HIGHWAY
VT ROUTE 279, PRINCIPAL ARTERIAL
BENNINGTON NH F019-1(5)

BEGINNING AT A POINT 68.419 m NORTH WEST OF VT ROUTE 9 AND EXTENDING
IN A NORTH AND WEST DIRECTION APPROXIMATELY 4.694 km

LENGTH OF ROADWAY = 4.369 km
LENGTH OF PROJECT = 4.694 km
LENGTH OF STRUCTURES = 0.325 km
LENGTH OF R.O.W. PROJECT = 4.908 km

WORK TO BE PERFORMED UNDER THIS PROJECT INCLUDES GRADING, DRAINAGE, SUBBASE,
AND PAVEMENT FOR A STATE HIGHWAY ON NEW LOCATION AND INVOLVES THE
CONSTRUCTION OF VT ROUTE 279 AROUND THE TOWN OF BENNINGTON, TWO NEW
INTERCHANGES, THE RECONSTRUCTION OF VT ROUTE 9, EAST ROAD, CHAPEL ROAD,
BALD MOUNTAIN TRAIL, A QUARRY ACCESS DRIVE AND VETERANS RESERVOIR ACCESS DRIVE.

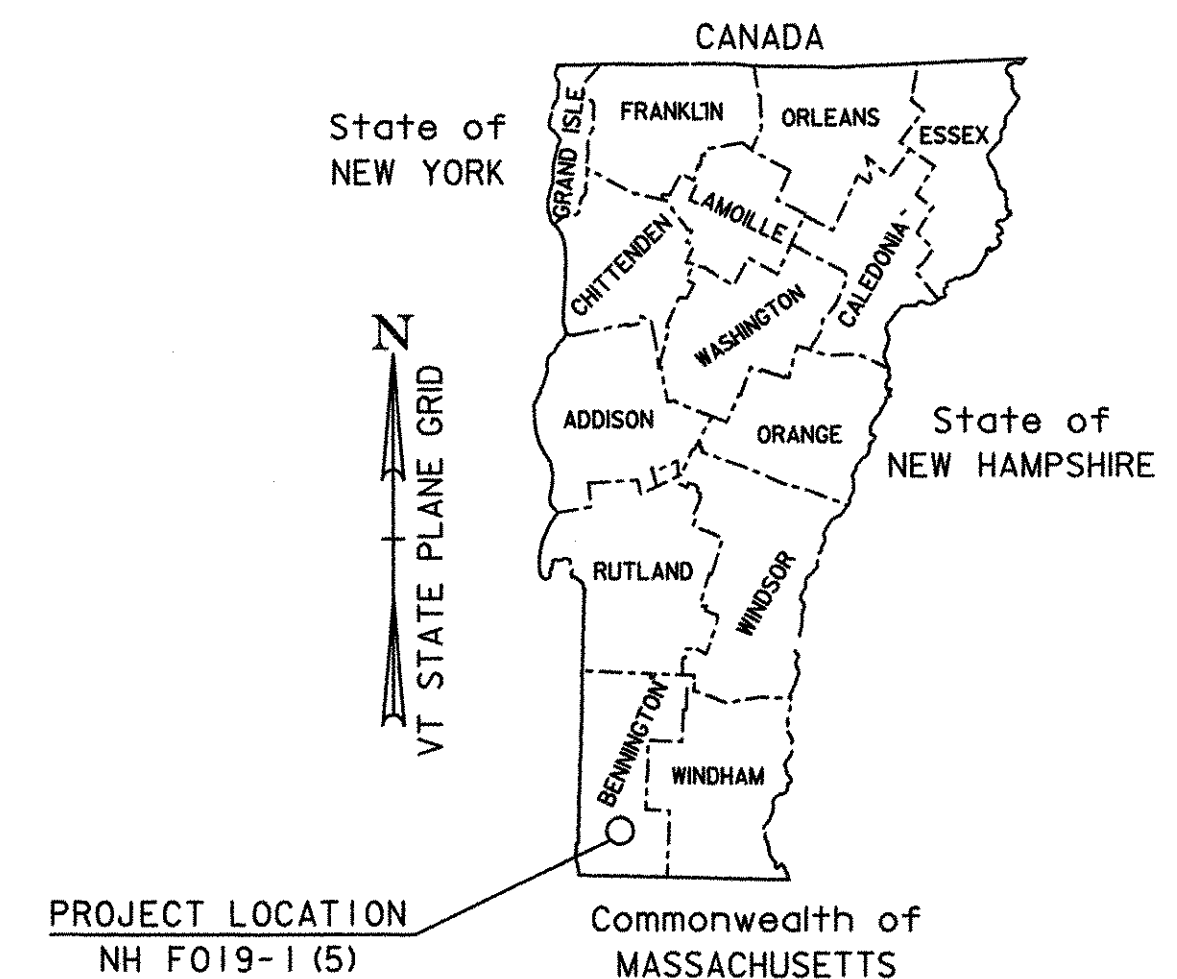

R.O.W. PLANS

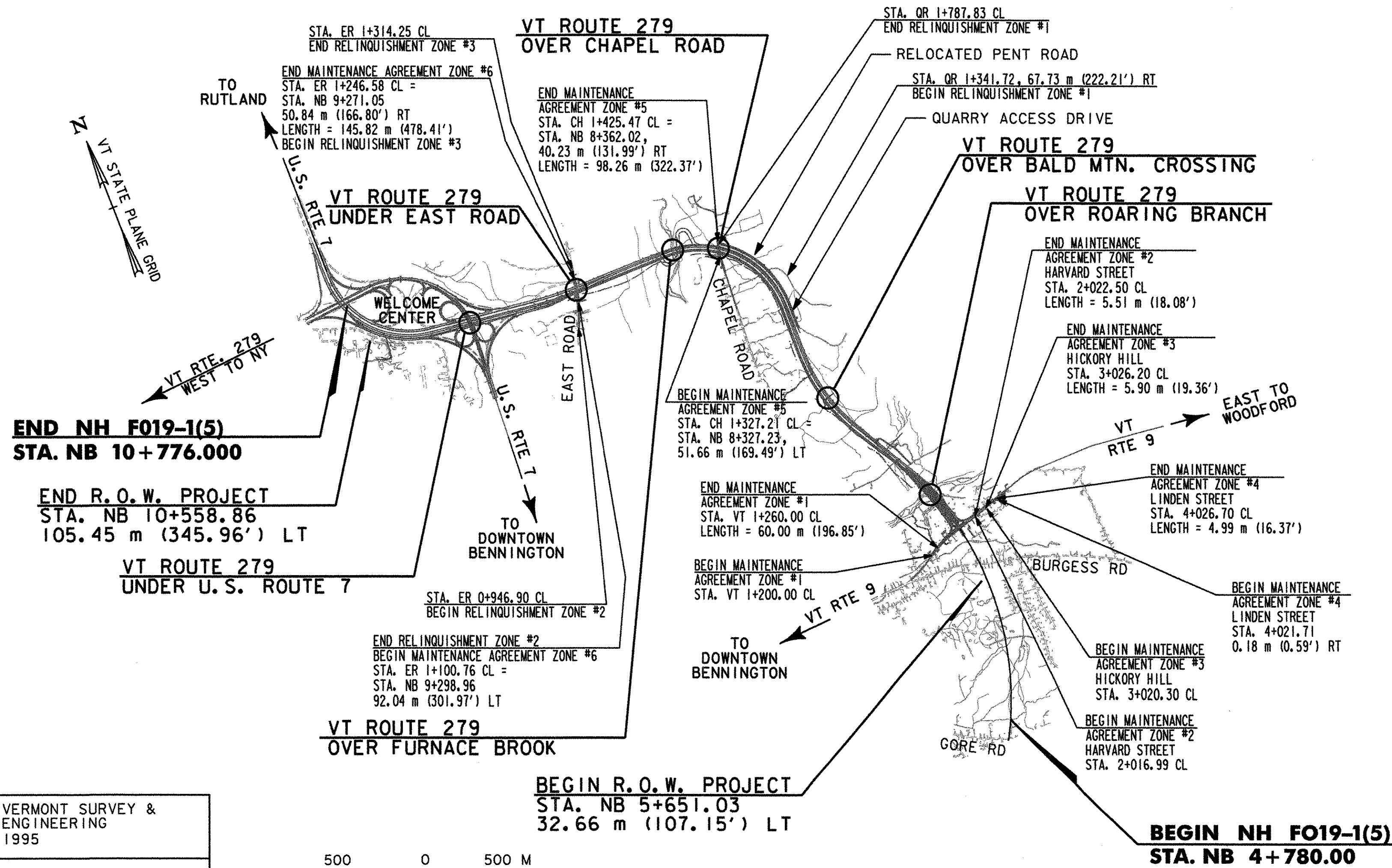

THESE PLANS ARE SUBJECT TO SUCH ENGINEERING CHANGES AS MAY BE REQUIRED BY THE FEDERAL HIGHWAY ADMINISTRATION OR THE DIRECTOR OF PROJECT DEVELOPMENT.

CONSTRUCTION IS TO BE CARRIED ON IN ACCORDANCE WITH THESE PLANS AND THE STANDARD SPECIFICATIONS FOR CONSTRUCTION DATED 2001, AS APPROVED BY THE FEDERAL HIGHWAY ADMINISTRATION ON JANUARY 4, 2001 FOR USE ON THIS PROJECT, INCLUDING ALL SUBSEQUENT REVISIONS AND SUCH REVISED SPECIFICATIONS AND SPECIAL PROVISIONS AS ARE INCORPORATED IN THESE PLANS.



UNLESS NOTED OTHERWISE
STATIONS ARE IN KILOMETERS
ELEVATIONS ARE IN METERS
DIMENSIONS ARE IN MILLIMETERS

APPROVED *Peter Scheibel* DATE 12-7-05
DIRECTOR OF PROGRAM DEVELOPMENT

APPROVED *William Mose* DATE 12/7/05
CHIEF OF RIGHT-OF-WAY

PROJECT NAME : BENNINGTON
PROJECT NUMBER : NH F019-1 (5)

R. O. W. SHEET 1 OF 112 SHEETS

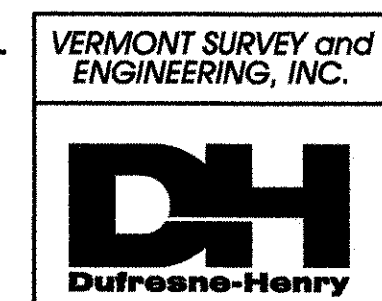

CONVENTIONAL SYMBOLS

| | |
|---------------------|--|
| COUNTY LINE | |
| TOWN LINE | |
| LIMITS OF ACCESS | |
| POINT OF ACCESS | |
| FENCE LINE | |
| STONE WALL | |
| TRAVELED WAY | |
| GUARD RAIL | |
| RAILROAD | |
| SURVEY LINE | |
| CULVERT | |
| POWER POLE | |
| TELEPHONE POLE | |
| TREES | |
| CONTROL OF ACCESS | |
| PROPERTY LINE | |
| R.O.W. TAKING LINE | |
| SLOPE RIGHTS | |
| TOP OF CUT | |
| TOE OF SLOPE | |
| ARCHAEOLOGICAL | |
| CLEAR ZONE | |
| WETLAND DELINEATION | |

SURVEYED BY : VERMONT SURVEY & ENGINEERING
SURVEYED DATE : 1995

DATUM
VERTICAL NAVD88
HORIZONTAL NAD83 (1992)

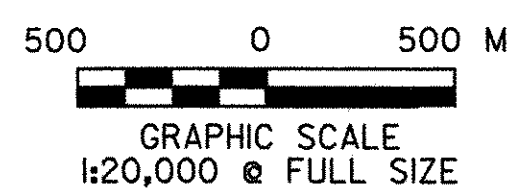

TYPICAL SECTION - MAINLINE (NB & SB)

| MATERIAL ITEM | THICKNESS TOLERANCE |
|--------------------------------|---------------------|
| PAVEMENT COURSES (TOTAL DEPTH) | +/- 5 mm |
| BASE COURSES (TOTAL DEPTH) | +/- 15 mm |
| SUBBASE | +/- 30 mm |
| SAND BORROW | +/- 30 mm |

| | |
|-------------------|---|
| 130 mm | SUPERPAVE BITUMINOUS CONCRETE PAVEMENT (50 mm TYPE IIS, 80 mm TYPE IIS) |
| 100 mm | BASE COURSE, SUPERPAVE BITUMINOUS CONCRETE PAVEMENT, TYPE IS |
| 600 mm | SUBBASE OF DENSE GRADED CRUSHED STONE |
| 400 mm | SAND BORROW |
| SHOULDERS: 130 mm | BITUMINOUS CONCRETE PAVEMENT (50 mm TYPE IIS, 80 mm TYPE IIS) |

NOTE:
1) DESIGN FROST DEPTH - 1230 MM

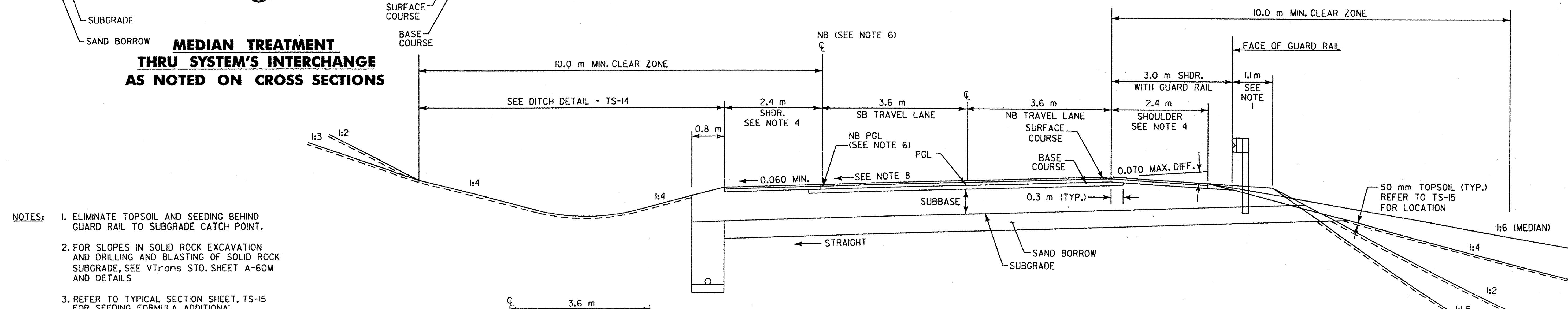
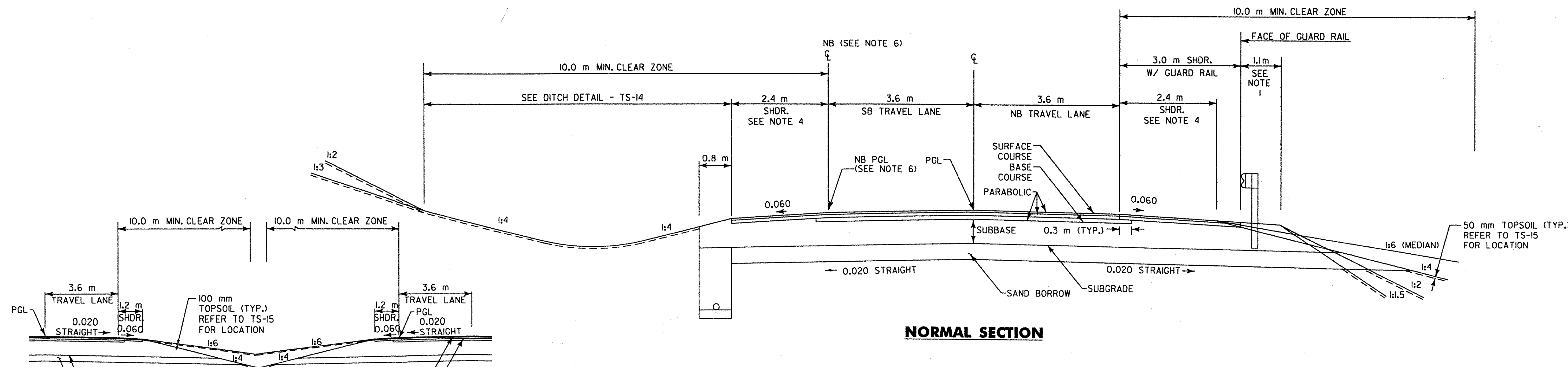

- NOTES:
- ELIMINATE TOPSOIL AND SEEDING BEHIND GUARD RAIL TO SUBGRADE CATCH POINT.
 - FOR SLOPES IN SOLID ROCK EXCAVATION AND DRILLING AND BLASTING OF SOLID ROCK SUBGRADE, SEE VTrans STD. SHEET A-60M AND DETAILS
 - REFER TO TYPICAL SECTION SHEET, TS-15 FOR SEEDING FORMULA, ADDITIONAL GENERAL NOTES AND PARABOLIC DETAIL.
 - USE 1.2 m SHOULDER THRU SYSTEMS INTERCHANGE ON INSIDE SHLDR. SEE ALIGNMENT PLANS
 - SEE TS-15 FOR LEDGE EXCAVATION DETAIL.
 - NB ϕ & PGL CARRIED AT LEFT TW FROM NB 8+958.0 TO 10+776.0
 - ANY DIMENSION NOTED AS "VARIES" IS REFERENCED TO ALIGNMENT PLANS/ SECTIONS FOR DETAIL.
 - SEE BANKING DIAGRAM ON PROFILES FOR CROSS SLOPE.

PGL=PROFILE GRADE LINE

VERMONT AGENCY OF TRANSPORTATION



PROJECT NAME: BENNINGTON
PROJECT NUMBER: NH F019-1(5)

REVISED

FILE NAME: ...Highway\PlotFiles\typicals.ptf
DESIGN SUPERVISOR: GREG EDWARDS
DESIGNED BY: MARC FOISY

PLOT DATE: 11/20/2004
DRAWN BY: DUFRESNE-HENRY
CHECKED BY: GARY SANTY
SHEET 2 OF 112

TYPICAL TS-01



TYPICAL SECTION - MAINLINE: WITH CLIMBING LANES

| MATERIAL ITEM | THICKNESS TOLERANCE |
|--------------------------------|---------------------|
| PAVEMENT COURSES (TOTAL DEPTH) | +/- 5 mm |
| BASE COURSES (TOTAL DEPTH) | +/- 15 mm |
| SUBBASE | +/- 30 mm |
| SAND BORROW | +/- 30 mm |

- 130 mm SUPERPAVE BITUMINOUS CONCRETE PAVEMENT (50 mm TYPE IIS, 80 mm TYPE IIS)
- 100 mm BASE COURSE, SUPERPAVE BITUMINOUS CONCRETE PAVEMENT, TYPE IS
- 600 mm SUBBASE OF DENSE GRADED CRUSHED STONE
- 400 mm SAND BORROW
- SHOULDERS: 130 mm BITUMINOUS CONCRETE PAVEMENT (50 mm TYPE IIS, 80 mm TYPE IIS)

NOTE:
1) DESIGN FROST DEPTH - 1230 MM

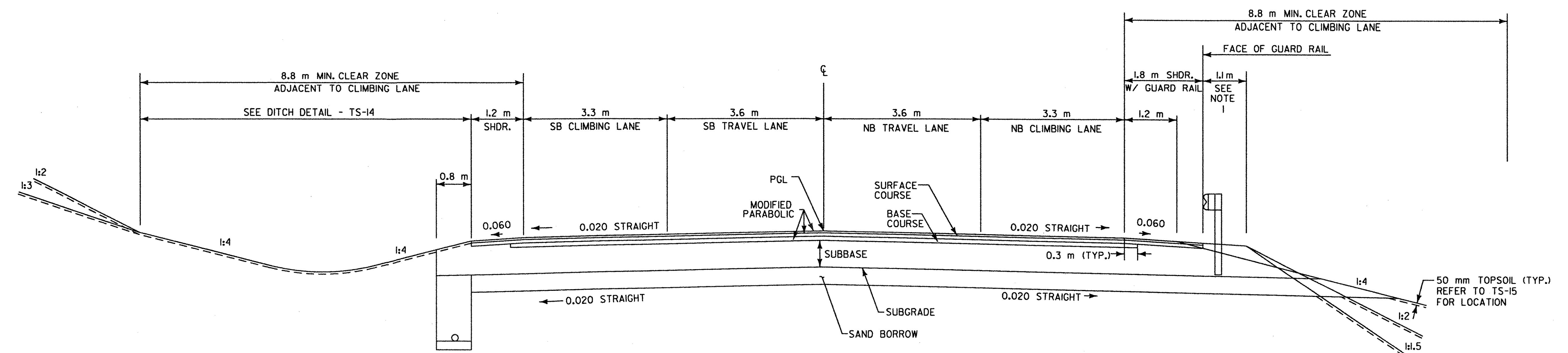

NORMAL SECTION W/ CLIMBING LANES

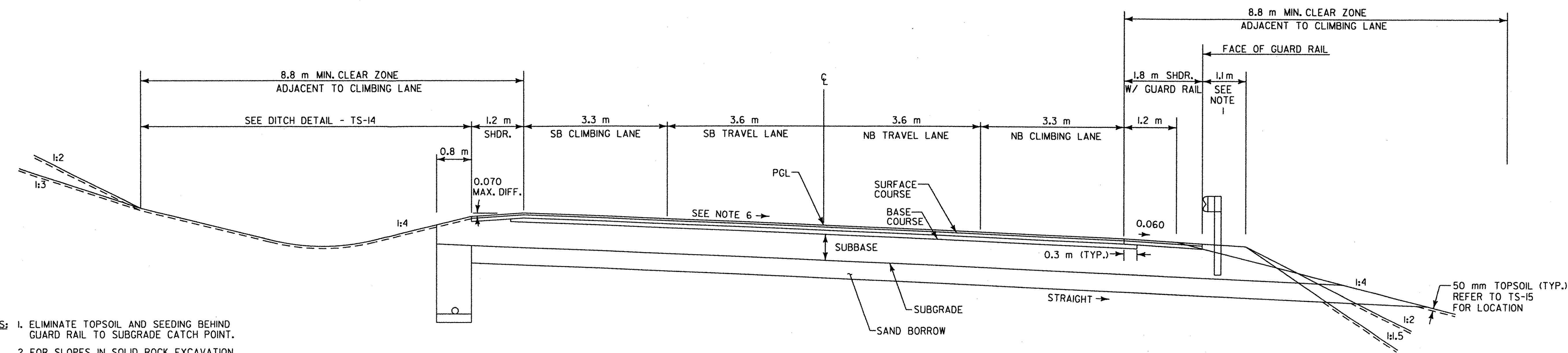

BANKED SECTION W/ CLIMBING LANES

- NOTES:
- ELIMINATE TOPSOIL AND SEEDING BEHIND GUARD RAIL TO SUBGRADE CATCH POINT.
 - FOR SLOPES IN SOLID ROCK EXCAVATION AND DRILLING AND BLASTING OF SOLID ROCK SUBGRADE, SEE VTRANS STD. SHEET A-60M AND A-62M AND DETAILS.
 - REFER TO TYPICAL SECTION SHEET, TS-15 FOR SEEDING FORMULA, ADDITIONAL GENERAL NOTES AND MODIFIED PARABOLIC DETAIL.
 - SEE TS-14 FOR LEDGE EXCAVATION DETAIL.
 - ANY DIMENSION NOTED AS "VARIES" IS REFERENCED TO ALIGNMENT PLANS/SECTIONS FOR DETAIL.
 - SEE BANKING DIAGRAM ON PROFILES FOR CROSS SLOPE.

| | |
|---|---|
| VERMONT AGENCY OF TRANSPORTATION | |
| DH Dufresne-Henry | REVISED |
| PROJECT NAME: BENNINGTON PROJECT NUMBER: NH F019-1(5) | DESIGN SUPERVISOR: GREG EDWARDS DESIGNED BY: MARC FOISY |
| FILE NAME: ...Highway\PlotFiles\typicals.ptf TYPICAL TS-02 | PLOT DATE: 11/20/2004 DRAWN BY: DUFRESNE-HENRY CHECKED BY: GARY SANTY SHEET 3 OF 112 |

PGL=PROFILE GRADE LINE

K:\3180020 (Benn)\Highway\PlotFiles\typicals.ptf

MATERIAL ITEM
PAVEMENT COURSES (TOTAL DEPTH)

THICKNESS
TOLERANCE
+/- 5 mm

TYPICAL SECTION MAINLINE - NORTHBOUND ONLY

65 mm SUPERPAVE BITUMINOUS CONCRETE PAVEMENT (50 mm TYPE III S, 15 mm TYPE IV S LEVELING)



NOTE: 1. SEE BANKING DIAGRAM ON PROFILES FOR CROSS SLOPE

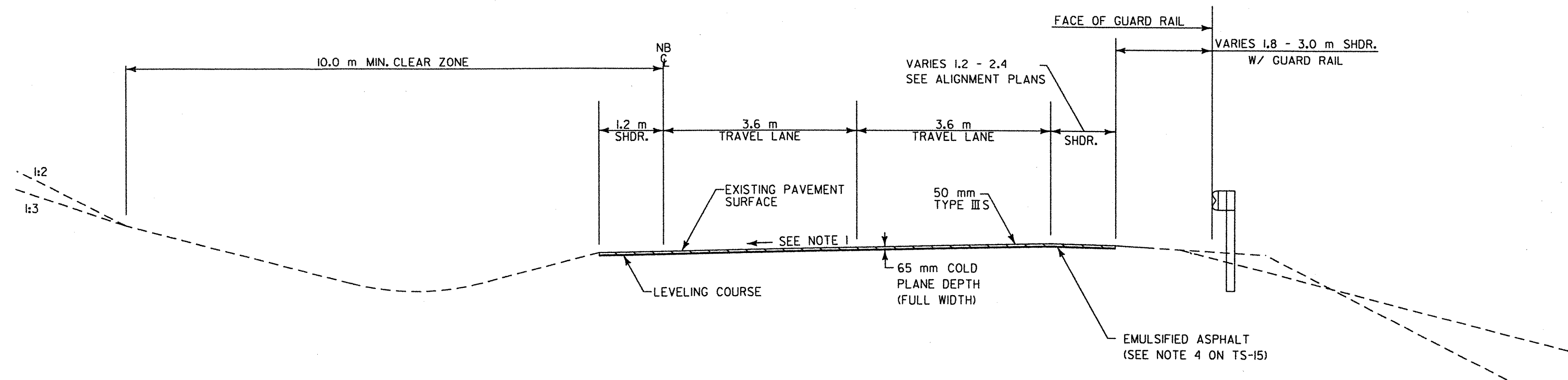

COLD PLANE SECTION

STA. NB 10+836 - NB 11+150

K:\A380020 - Bennington\Highway\PlotFiles\Typicals.ppt

| | |
|--|--|
| VERMONT AGENCY OF TRANSPORTATION | |
| DH Dufresne-Henry | PROJECT NAME: BENNINGTON PROJECT NUMBER: NH F019-1(5) |
| | REVISED |
| DESIGN SUPERVISOR: GREG EDWARDS DESIGNED BY: MARC FOISY | FILE NAME: ...Highway\PlotFiles\typicals.ppt PLOT DATE: 11/9/2004 DRAWN BY: DUFRESNE-HENRY CHECKED BY: GARY SANTY |
| TYPICAL TS-02A | |
| SHEET 4 OF 112 | |

PGL = PROFILE GRADE LINE

TYPICAL SECTION - CROSSOVER



| MATERIAL ITEM | THICKNESS TOLERANCE |
|--------------------------------|---------------------|
| PAVEMENT COURSES (TOTAL DEPTH) | +/- 5 mm |
| BASE COURSES (TOTAL DEPTH) | +/- 15 mm |
| SUBBASE | +/- 30 mm |
| SAND BORROW | +/- 30 mm |

- 130 mm SUPERPAVE BITUMINOUS CONCRETE PAVEMENT (50mm TYPE IIS, 80mm TYPE IIS)
- 100 mm BASE COURSE, SUPERPAVE BITUMINOUS CONCRETE PAVEMENT, TYPE IS
- 600 mm SUBBASE OF DENSE GRADED CRUSHED STONE
- 400 mm SAND BORROW
- SHOULDERS: 130 mm BITUMINOUS CONCRETE PAVEMENT (50 mm TYPE IIS, 80 mm TYPE IIS)

NOTE:
 1) DESIGN FROST DEPTH - 1230 MM

- NOTES:**
- ELIMINATE TOPSOIL AND SEEDING BEHIND GUARD RAIL TO SUBGRADE CATCH POINT.
 - FOR SLOPES IN SOLID ROCK EXCAVATION AND DRILLING AND BLASTING OF SOLID ROCK SUBGRADE, SEE VTTRANS STD. SHEET A-60M AND A-62M AND DETAILS
 - REFER TO TYPICAL SECTION SHEET, TS-15 FOR SEEDING FORMULA AND ADDITIONAL GENERAL NOTES AND PARABOLIC DETAIL
 - SEE TS-14 FOR LEDGE EXCAVATION DETAIL.
 - ANY DIMENSION NOTED AS "VARIES" IS REFERENCED TO ALIGNMENT PLANS/SECTIONS FOR DETAIL.
 - SEE BANKING DIAGRAM ON PROFILES FOR CROSS SLOPE

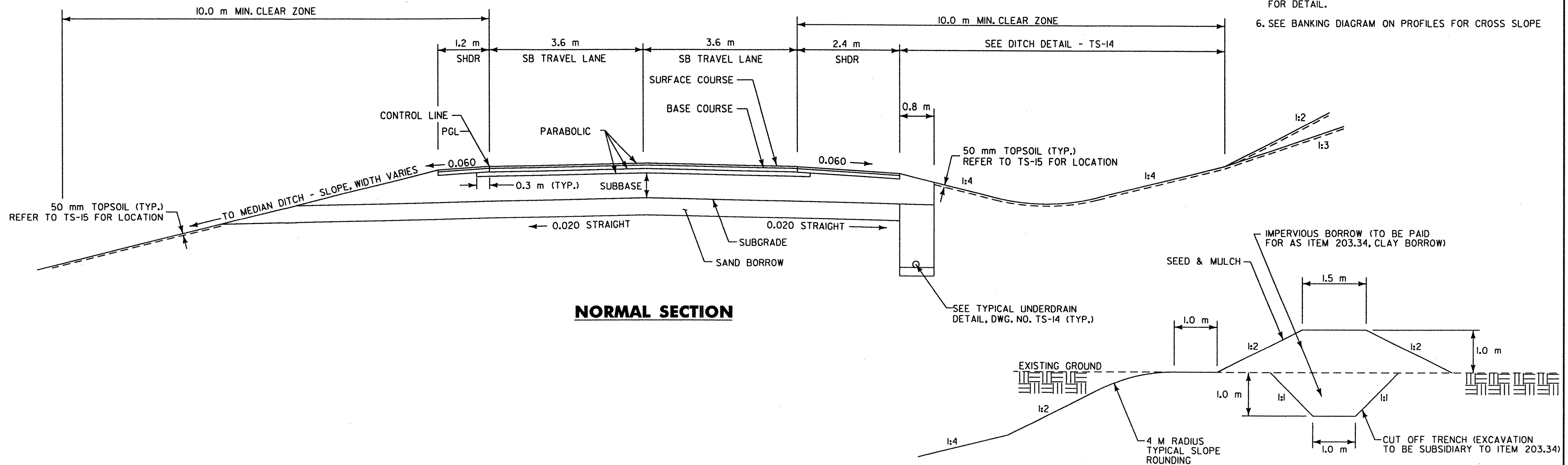

BERM FOR WETLAND "W"
 STA. CD 2+400, RT. TO XO 1+225, RT.

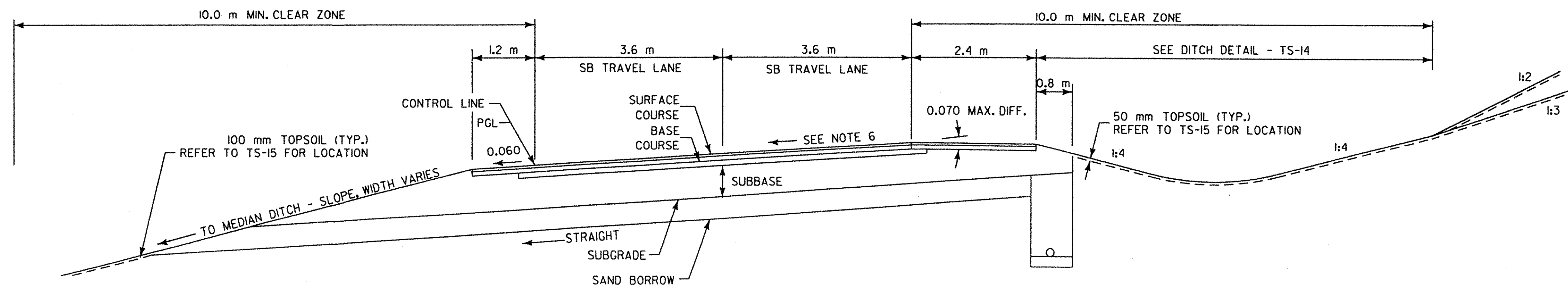

PGL = PROFILE GRADE LINE

| | |
|--|---|
| VERMONT AGENCY OF TRANSPORTATION | |
| | PROJECT NAME: BENNINGTON |
| | PROJECT NUMBER: NH FO19-1(5) REVISED |
| FILE NAME: ...Highway\PlotFiles\typicals.ppf | PLOT DATE: 11/20/2004 |
| DESIGN SUPERVISOR: GREG EDWARDS | DRAWN BY: DUFRESNE-HENRY |
| DESIGNED BY: MARC FOISY | CHECKED BY: GARY SANTY |
| TYPICAL TS-03 | SHEET 5 OF 112 |

K:\ASB\020 (Bennington)\Highway\PlotFiles\typicals.ppf

TYPICAL REPRESENTATIVE SECTION - MAINLINE-RAMPS THROUGH S.P.D.I.

REPRESENTATIVE SECTION ONLY - ROUTE 9 : ROUTE 7 SPDI
FOR FULL BUILD OF NORTHBOUND

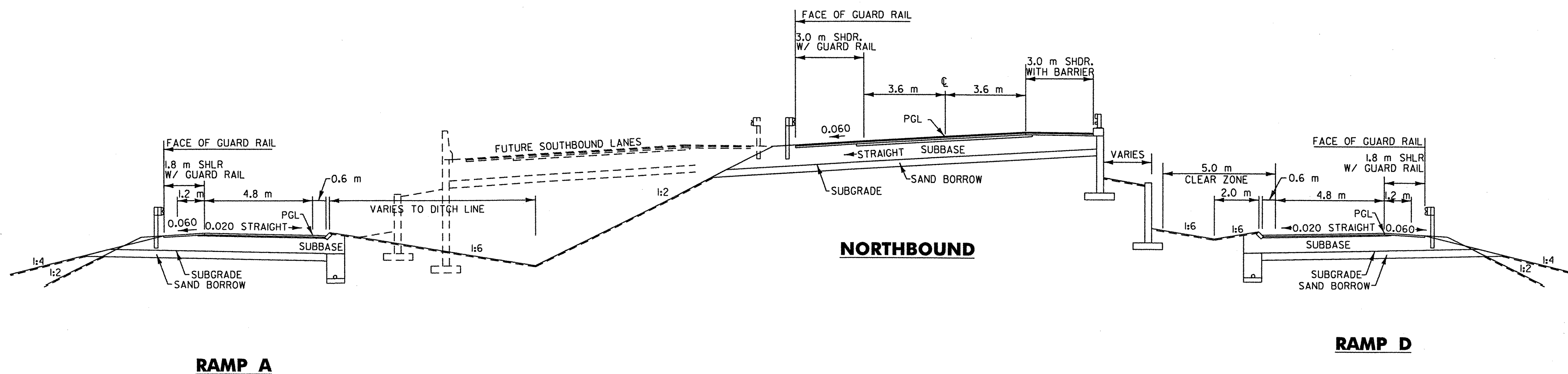

K:\6380020 (Bennington)\Highway\PlotFiles\typicals.pxf

PGL=PROFILE GRADE LINE

| | |
|--|---|
| VERMONT AGENCY OF TRANSPORTATION | |
| | PROJECT NAME: BENNINGTON |
| | PROJECT NUMBER: NH F019-1(5) REVISED |
| FILE NAME: ...Highway\PlotFiles\typicals.pxf | PLOT DATE: 11/9/2004 |
| DESIGN SUPERVISOR: GREG EDWARDS | DRAWN BY: DUFRESNE-HENRY |
| DESIGNED BY: MARC FOISY | CHECKED BY: GARY SANTY |
| TYPICAL TS-04 | SHEET 6 OF 112 |

TYPICAL SECTION RT 9 INTERCHANGE - RAMPS A&D



| MATERIAL ITEM | THICKNESS TOLERANCE |
|--------------------------------|---------------------|
| PAVEMENT COURSES (TOTAL DEPTH) | +/- 5 mm |
| BASE COURSES (TOTAL DEPTH) | +/- 15 mm |
| SUBBASE | +/- 30 mm |
| SAND BORROW | +/- 30 mm |

130 mm SUPERPAVE BITUMINOUS CONCRETE PAVEMENT (50 mm TYPE IIS, 80 mm TYPE IIS)
 100 mm BASE COURSE, SUPERPAVE BITUMINOUS CONCRETE PAVEMENT, TYPE IS
 600 mm SUBBASE OF DENSE GRADED CRUSHED STONE
 400 mm SAND BORROW

SHOULDERS: 130 mm BITUMINOUS CONCRETE PAVEMENT (50 mm TYPE IIS, 80 mm TYPE IIS)

NOTE:
 1) DESIGN FROST DEPTH - 1230 mm

NOTES:

1. ELIMINATE TOPSOIL AND SEEDING BEHIND GUARD RAIL TO SUBGRADE CATCH POINT.
2. FOR SLOPES IN SOLID ROCK EXCAVATION AND DRILLING AND BLASTING OF SOLID ROCK SUBGRADE, SEE STD. SHEET A-60M AND A-62M AND DETAILS
3. REFER TO TYPICAL SECTION SHEET, TS-15 FOR SEEDING FORMULA AND ADDITIONAL GENERAL NOTES.

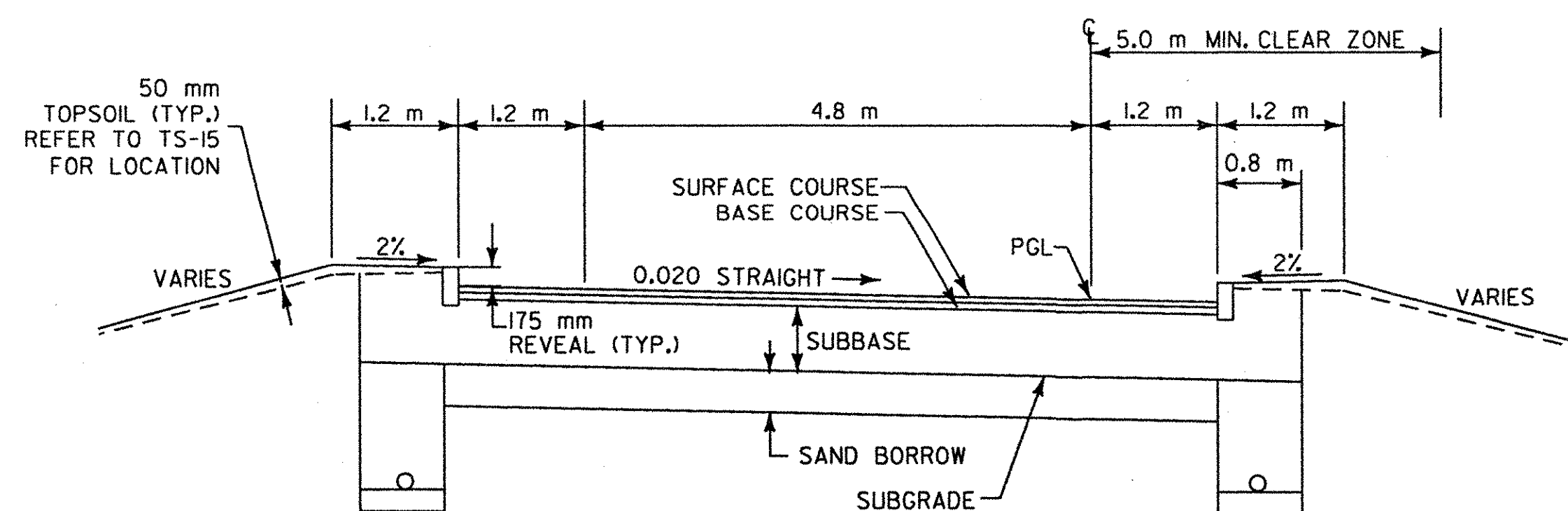

VERTICAL CURB SECTION
STA. A 1+048 - STA. A 1+077
STA. D 1+045 - STA. D 1+080
STA. AS 1+000 - STA. AS 1+029
STA. DS 1+000 - STA. AS 1+036

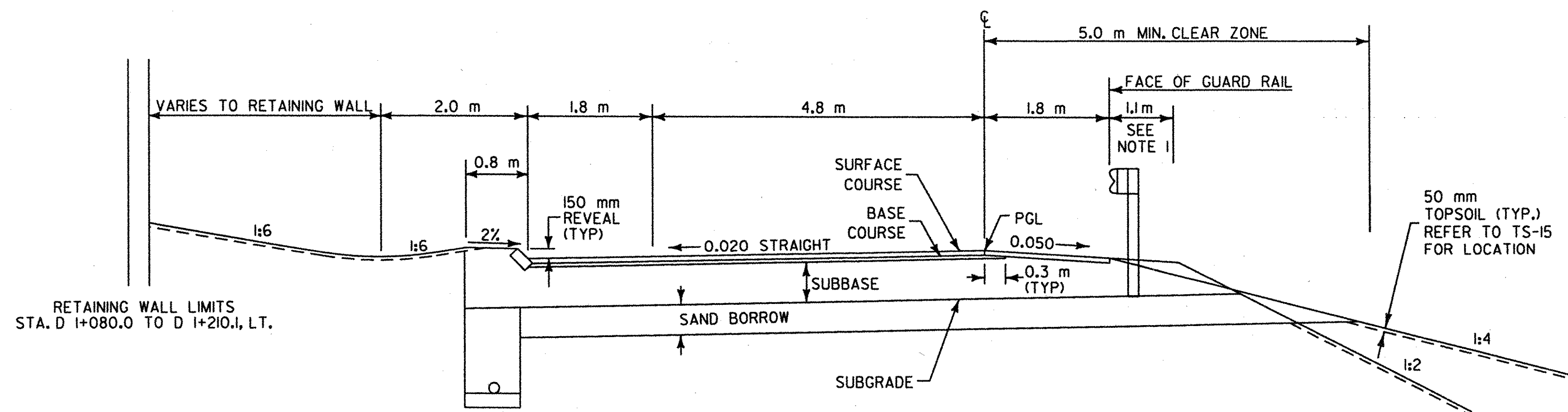

NORMAL SECTION
STA. D 1+080 - STA. D 1+235
 GRANITE SLOPE EDGING MATCHES TO BRIDGE CURB ON SHEET P-6 AT STATION D 1+226.0

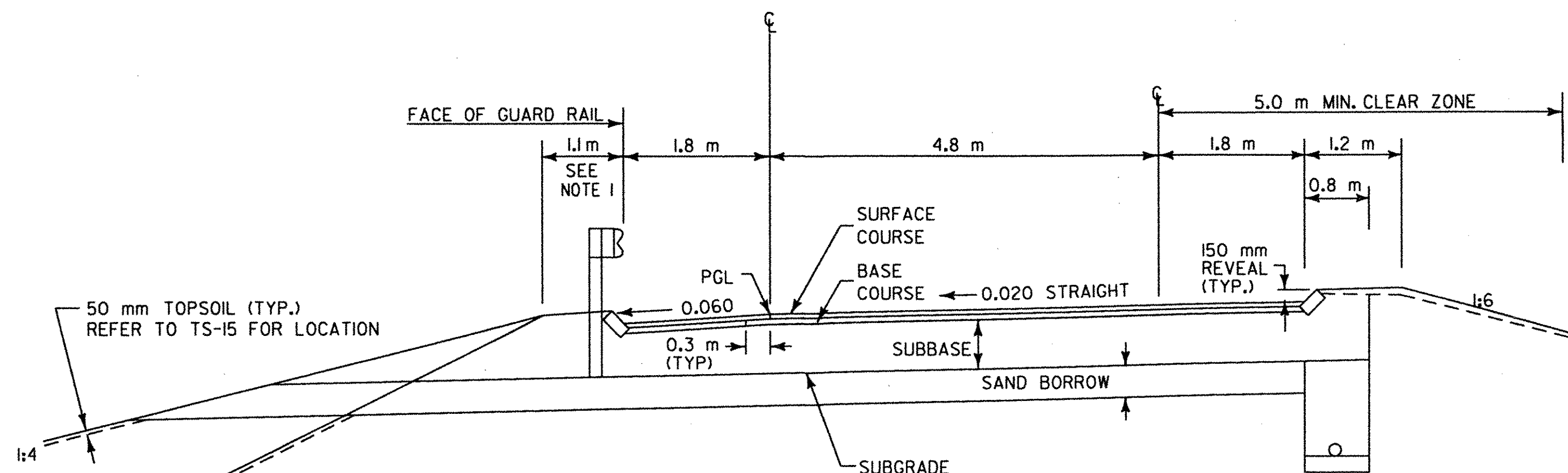

NORMAL SECTION
STA. A 1+077 - STA. A 1+241
 GRANITE SLOPE EDGING MATCHES TO BRIDGE CURB ON SHEET P-6 AT STATION A 1+234.0

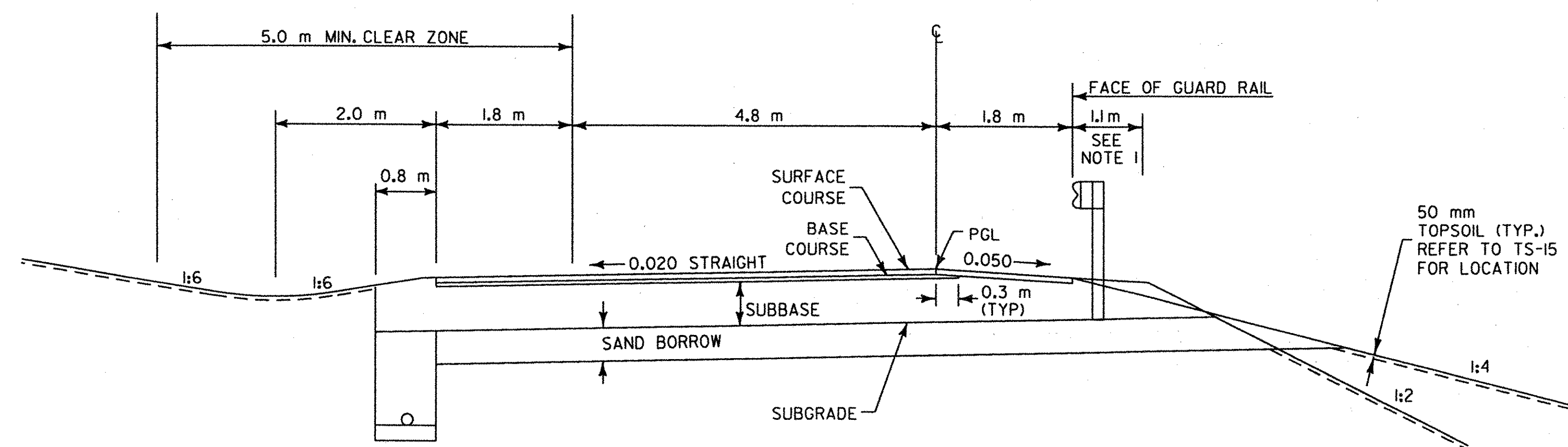

NORMAL SECTION NO CURB
STA. A 1+389 - STA. A 1+600
STA. D 1+381 - STA. D 1+591

VERMONT AGENCY OF TRANSPORTATION



PROJECT NAME: BENNINGTON
 PROJECT NUMBER: NH F019-(15)

REVISED

FILE NAME: ...Highway\PlotFiles\typicals.pxf PLOT DATE: 11/20/2004
 DESIGN SUPERVISOR: GREG EDWARDS DRAWN BY: DUFRESNE-HENRY
 DESIGNED BY: MARC FOISY CHECKED BY: GARY SANTY
TYPICAL TS-05 SHEET 7 OF 112

PGL=PROFILE GRADE LINE

TYPICAL SECTION - SYSTEM INTERCHANGE RAMPS E,F,G,H,K,L,M,N,P,Q,R,S



| MATERIAL ITEM | THICKNESS TOLERANCE |
|--------------------------------|---------------------|
| PAVEMENT COURSES (TOTAL DEPTH) | +/- 5 mm |
| BASE COURSES (TOTAL DEPTH) | +/- 15 mm |
| SUBBASE | +/- 30 mm |
| SAND BORROW | +/- 30 mm |

SHOULDERS: 130 mm BITUMINOUS CONCRETE PAVEMENT (50 mm TYPE IIS, 80 mm TYPE IIS)

130 mm BITUMINOUS CONCRETE PAVEMENT (50 mm TYPE IIS, 80 mm TYPE IIS)
 100 mm BASE COURSE, BITUMINOUS CONCRETE, TYPE IS
 600 mm SUBBASE OF DENSE GRADED CRUSHED STONE
 400 mm SAND BORROW

NOTE:
 1) DESIGN FROST DEPTH - 1230 MM

- NOTES:
- ELIMINATE TOPSOIL AND SEEDING BEHIND GUARD RAIL TO SUBGRADE CATCH POINT.
 - FOR SLOPES IN SOLID ROCK EXCAVATION AND DRILLING AND BLASTING OF SOLID ROCK SUBGRADE, SEE STD. SHEET A-60M AND A-62M AND DETAILS
 - REFER TO TYPICAL SECTION SHEET, TS-15 FOR SEEDING FORMULA AND ADDITIONAL GENERAL NOTES.
 - SEE TS-14 FOR LEDGE EXCAVATION DETAIL.
 - SEE BANKING DIAGRAM ON PROFILES FOR CROSS SLOPE

— SURFACE COURSE
 — BASE COURSE
 — SUBGRADE
 RB

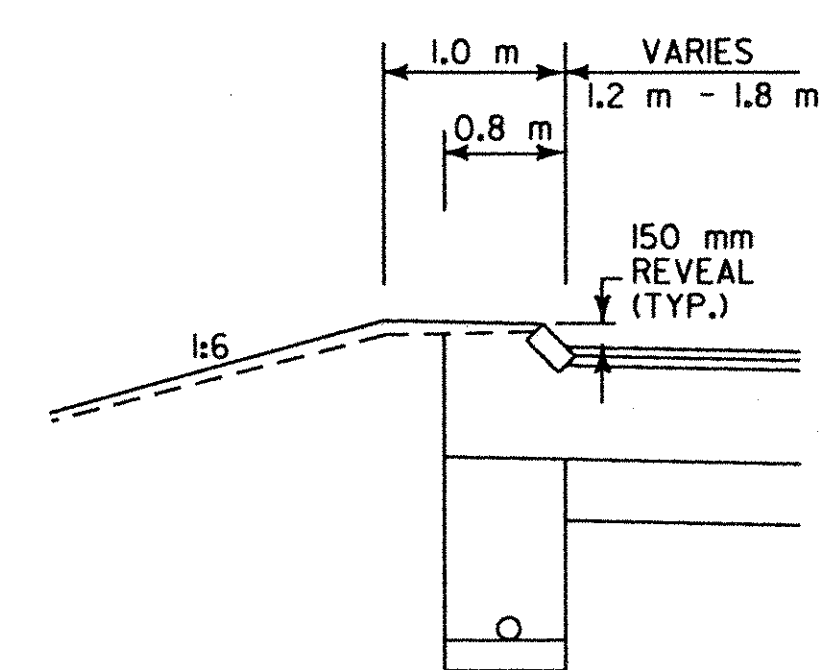

**SECTION W/SLOPE CURB
 RAMPS P, Q, R, S**

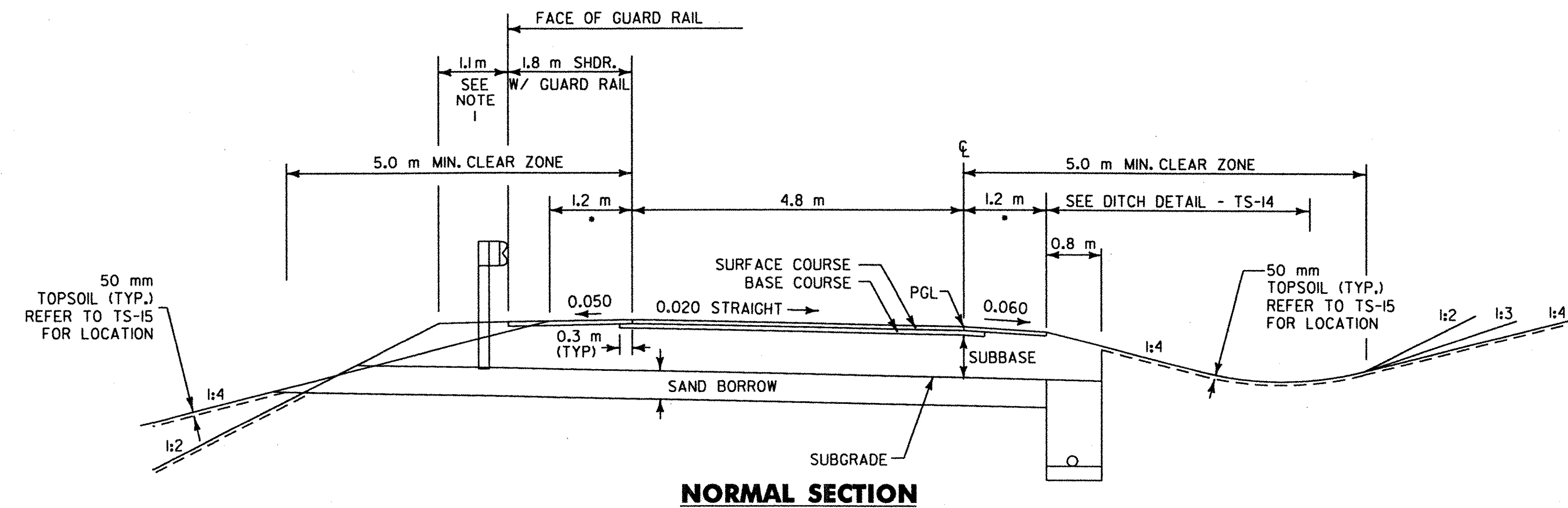

NORMAL SECTION

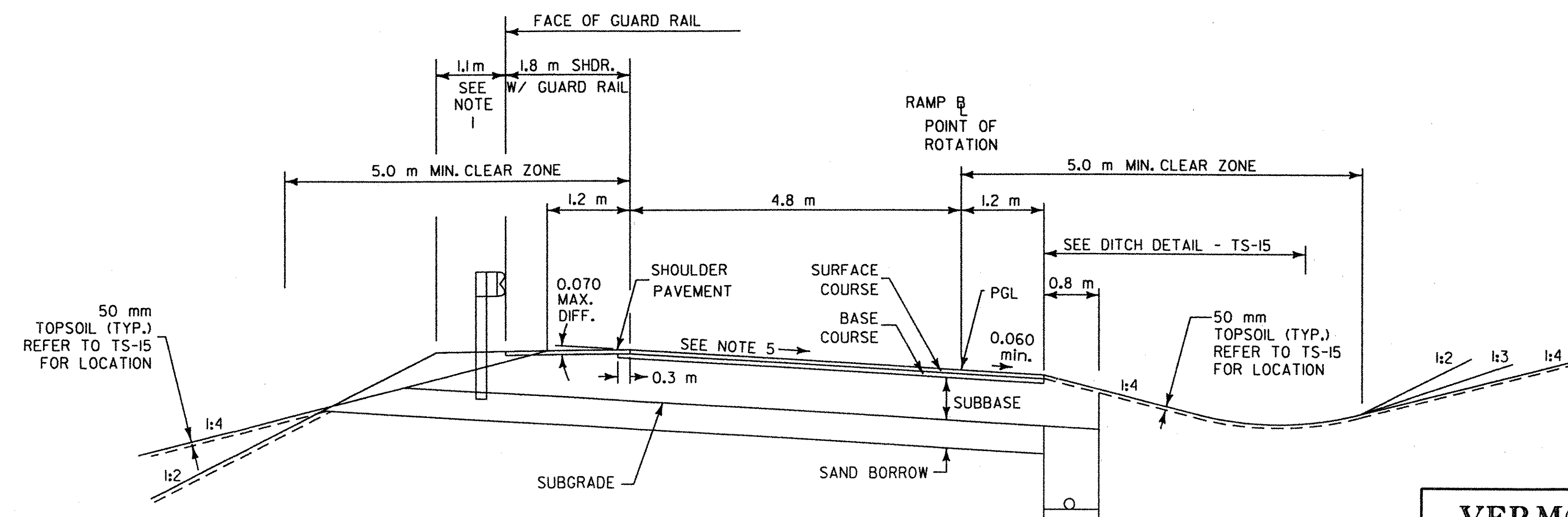

BANKED SECTION

PGL = PROFILE GRADE LINE

| | |
|---|---|
| VERMONT AGENCY OF TRANSPORTATION | |
| | REVISED |
| | PROJECT NAME: BENNINGTON PROJECT NUMBER: NH F019-1(5) FILE NAME: ...Highway\PlotFiles\typicals.ptf DESIGN SUPERVISOR: GREG EDWARDS DESIGNED BY: MARC FOISY TYPICAL TS-06 |
| PLOT DATE: 11/20/2004 DRAWN BY: DUFRESNE-HENRY CHECKED BY: GARY SANTY SHEET 8 OF 112 | |

K:\380020 (Berm)\Highway\PlotFiles\typicals.ptf

| MATERIAL ITEM | THICKNESS TOLERANCE |
|--------------------------------|---------------------|
| PAVEMENT COURSES (TOTAL DEPTH) | +/- 5 mm |

TYPICAL SECTION U.S. RTE. 7 CONNECTOR



65 mm SUPERPAVE BITUMINOUS CONCRETE PAVEMENT (50 mm TYPE III S, 15 mm TYPE IV S LEVELING)

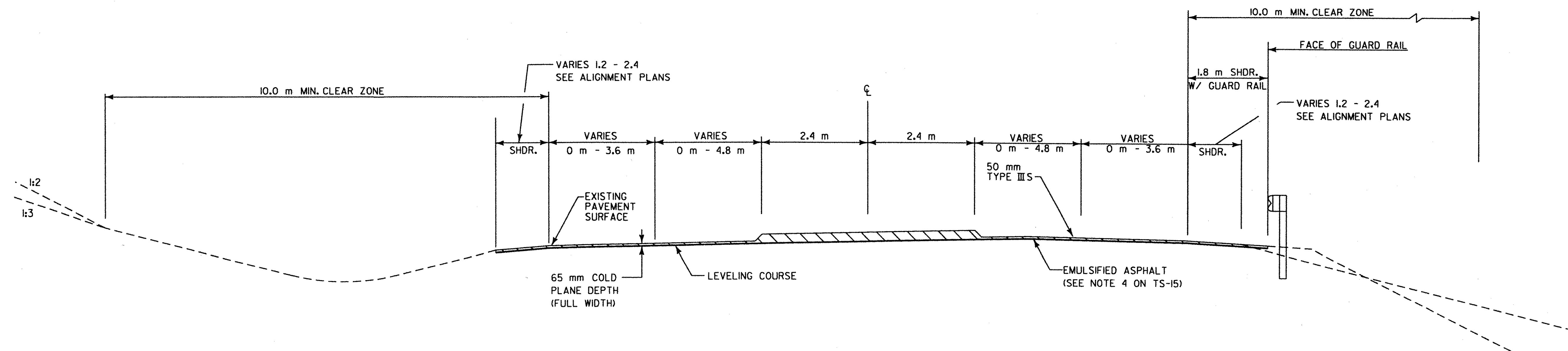

COLD PLANE SECTION
STA. CN 1+260 - CN 1+500

K:\680020 - Bennington\Highway\PlotFiles\typicals.prf

PGL = PROFILE GRADE LINE

| | |
|---|--|
| VERMONT AGENCY OF TRANSPORTATION | |
| | PROJECT NAME: BENNINGTON PROJECT NUMBER: NH F019-1(5) FILE NAME: ...Highway\PlotFiles\typicals.prf DESIGN SUPERVISOR: GREG EDWARDS DESIGNED BY: MARC FOISY TYPICAL TS-07 |
| REVISED PLOT DATE: 11/20/2004 DRAWN BY: DUFRESNE-HENRY CHECKED BY: GARY SANTY SHEET 9 OF 112 | |



TYPICAL SECTION - U.S. RTE. 7 CONNECTOR

| MATERIAL ITEM | THICKNESS TOLERANCE |
|--------------------------------|---------------------|
| PAVEMENT COURSES (TOTAL DEPTH) | +/- 5 mm |
| BASE COURSES (TOTAL DEPTH) | +/- 15 mm |
| SUBBASE | +/- 30 mm |
| SAND BORROW | +/- 30 mm |

| | |
|-------------------|---|
| 130 mm | SUPERPAVE BITUMINOUS CONCRETE PAVEMENT (50 mm TYPE IIS, 80 mm TYPE IIS) |
| 100 mm | BASE COURSE, SUPERPAVE BITUMINOUS CONCRETE PAVEMENT, TYPE IS |
| 600 mm | SUBBASE OF DENSE GRADED CRUSHED STONE |
| 400 mm | SAND BORROW |
| SHOULDERS: 130 mm | BITUMINOUS CONCRETE PAVEMENT (50 mm TYPE IIS, 80 mm TYPE IIS) |

- NOTES:**
- ELIMINATE TOPSOIL AND SEEDING BEHIND GUARD RAIL TO SUBGRADE CATCH POINT.
 - FOR SLOPES IN SOLID ROCK EXCAVATION AND DRILLING AND BLASTING OF SOLID ROCK SUBGRADE, SEE VTRANS STD. SHEET A-60M AND A-62M AND DETAILS
 - REFER TO TYPICAL SECTION SHEET, TS-15 FOR SEEDING FORMULA AND ADDITIONAL GENERAL NOTES.
 - REFER TO TS-14 FOR LEDGE EXCAVATION DETAIL.
 - SEE BANKING DIAGRAM ON PROFILES FOR CROSS SLOPE

NOTE:
1) DESIGN FROST DEPTH - 1230 MM

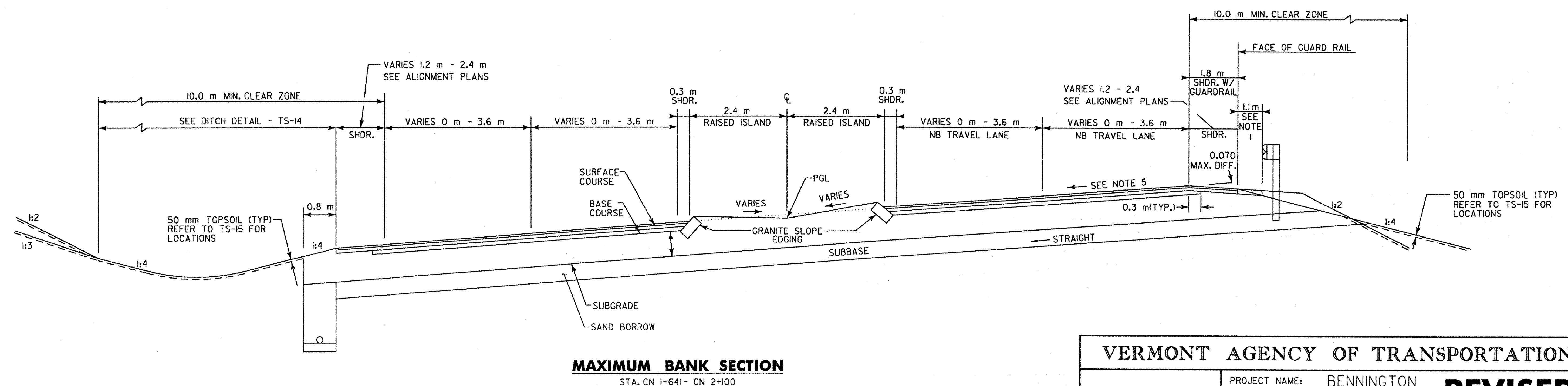
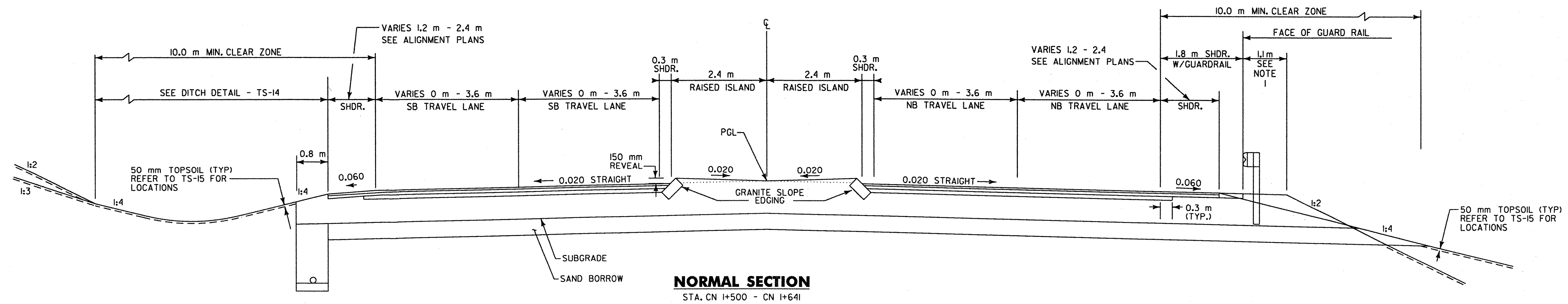

VERMONT AGENCY OF TRANSPORTATION

DH
Dufresne-Henry

PROJECT NAME: BENNINGTON
PROJECT NUMBER: NH F019-1(5)

REVISED

FILE NAME: ...Highway\PlotFiles\typicals.pff
DESIGN SUPERVISOR: GREG EDWARDS
DESIGNED BY: MARC FOISY

PLOT DATE: 11/20/2004
DRAWN BY: DUFRESNE-HENRY
CHECKED BY: GARY SANTY

TYPICAL TS-08
SHEET 10 OF 112

PGL = PROFILE GRADE LINE

K:\638020 (Bennington)\Highway\PlotFiles\typicals.pff

TYPICAL SECTION - U.S. RTE. 7 CONNECTOR

| MATERIAL ITEM | THICKNESS TOLERANCE |
|--------------------------------|---------------------|
| PAVEMENT COURSES (TOTAL DEPTH) | +/- 5 mm |
| BASE COURSES (TOTAL DEPTH) | +/- 15 mm |
| SUBBASE | +/- 30 mm |
| SAND BORROW | +/- 30 mm |

| | |
|-------------------|--|
| 130 mm | SUPERPAVE BITUMINOUS CONCRETE PAVEMENT (50 mm TYPE IIS, 80 mm TYPE IS) |
| 100 mm | BASE COURSE, SUPERPAVE BITUMINOUS CONCRETE PAVEMENT, TYPE IS |
| 600 mm | SUBBASE OF DENSE GRADED CRUSHED STONE |
| 400 mm | SAND BORROW |
| SHOULDERS: 130 mm | BITUMINOUS CONCRETE PAVEMENT (50 mm TYPE IIS, 80 mm TYPE IS) |

NOTE:
1) DESIGN FROST DEPTH - 1230 MM

- NOTES:**
1. ELIMINATE TOPSOIL AND SEEDING BEHIND GUARD RAIL TO SUBGRADE CATCH POINT.
 2. FOR SLOPES IN SOLID ROCK EXCAVATION AND DRILLING AND BLASTING OF SOLID ROCK SUBGRADE, SEE VTTRANS STD. SHEET A-60M AND A-62M AND DETAILS
 3. REFER TO TYPICAL SECTION SHEET, TS-15 FOR SEEDING FORMULA AND ADDITIONAL GENERAL NOTES AND MODIFIED PARABOLIC DETAIL.
 4. REFER TO TS-14 FOR LEDGE EXCAVATION DETAIL.
 5. SEE BANKING DIAGRAM ON PROFILES FOR CROSS SLOPE

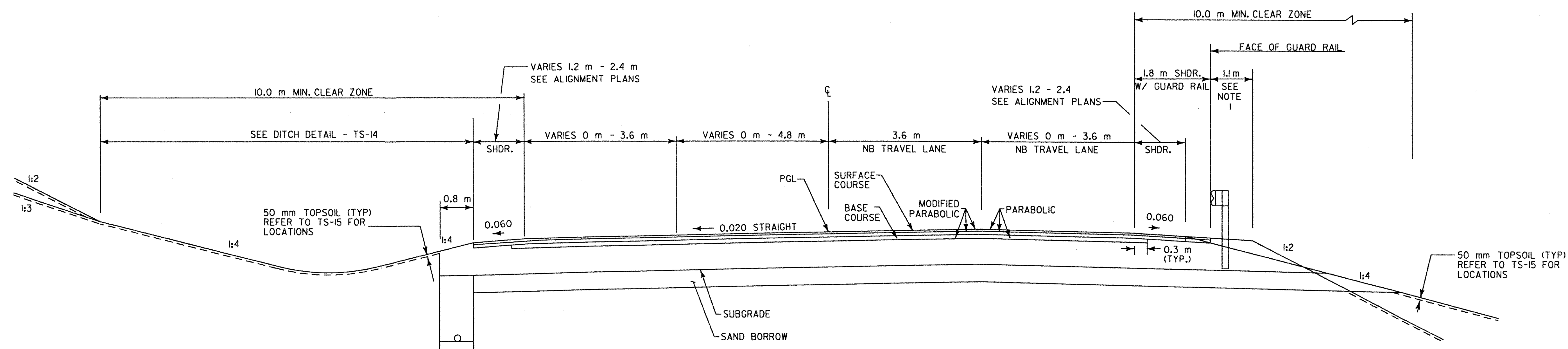

NORMAL SECTION

STA. CN 2+492 - CN 2+660

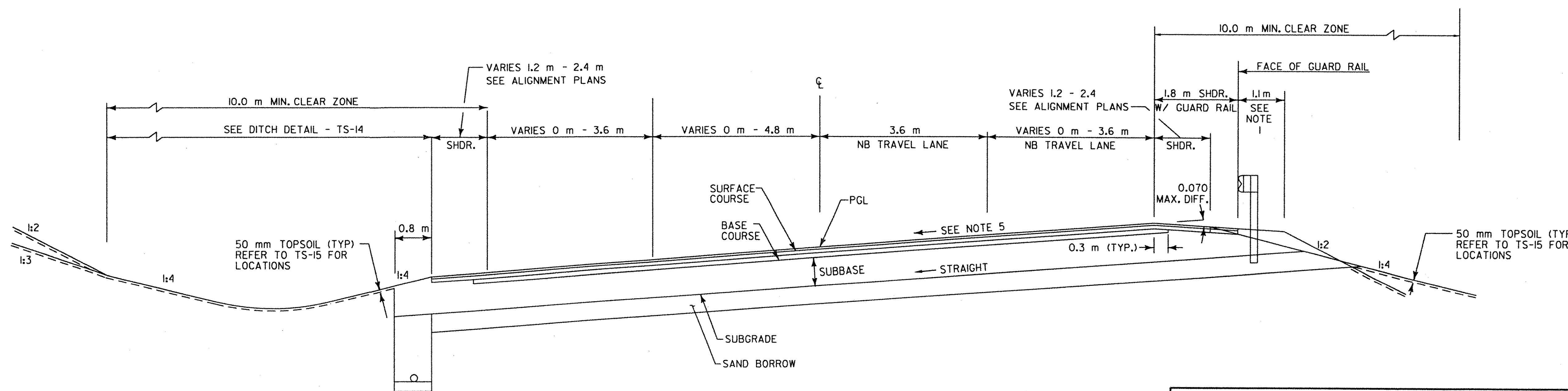

MAXIMUM BANK SECTION

STA. CN 2+000 - CN 2+492

VERMONT AGENCY OF TRANSPORTATION



PROJECT NAME: BENNINGTON

PROJECT NUMBER: NH F019-1(5)

FILE NAME: ...Highway\PlotFiles\typicals.ptf

DESIGN SUPERVISOR: GREG EDWARDS

DESIGNED BY: MARC FOISY

TYPICAL TS-08a

REVISED

PLOT DATE: 11/23/2004

DRAWN BY: DUFRESNE-HENRY

CHECKED BY: GARY SANTY

SHEET 11 OF 112

PGL = PROFILE GRADE LINE

TYPICAL SECTION - COLLECTOR / DISTRIBUTOR



| MATERIAL ITEM | THICKNESS TOLERANCE |
|--------------------------------|---------------------|
| PAVEMENT COURSES (TOTAL DEPTH) | +/- 5 mm |
| BASE COURSES (TOTAL DEPTH) | +/- 15 mm |
| SUBBASE | +/- 30 mm |
| SAND BORROW | +/- 30 mm |

SHOULDERS: 130 mm SUPERPAVE BITUMINOUS CONCRETE PAVEMENT (50 mm TYPE IIS, 80 mm TYPE IIS)
 100 mm BASE COURSE, SUPERPAVE BITUMINOUS CONCRETE PAVEMENT, TYPE IS
 600 mm SUBBASE OF DENSE GRADED CRUSHED STONE
 400 mm SAND BORROW

NOTE:
 1) DESIGN FROST DEPTH - 1230 MM

- NOTES:
1. ELIMINATE TOPSOIL AND SEEDING BEHIND GUARD RAIL TO SUBGRADE CATCH POINT.
 2. FOR SLOPES IN SOLID ROCK EXCAVATION AND DRILLING AND BLASTING OF SOLID ROCK SUBGRADE, SEE STD. SHEET A-60M AND A-62M AND DETAILS
 3. REFER TO TYPICAL SECTION SHEET, TS-15 FOR SEEDING FORMULA AND ADDITIONAL GENERAL NOTES AND PARABOLIC DETAIL.
 4. SEE BANKING DIAGRAM ON PROFILES FOR CROSS SLOPE

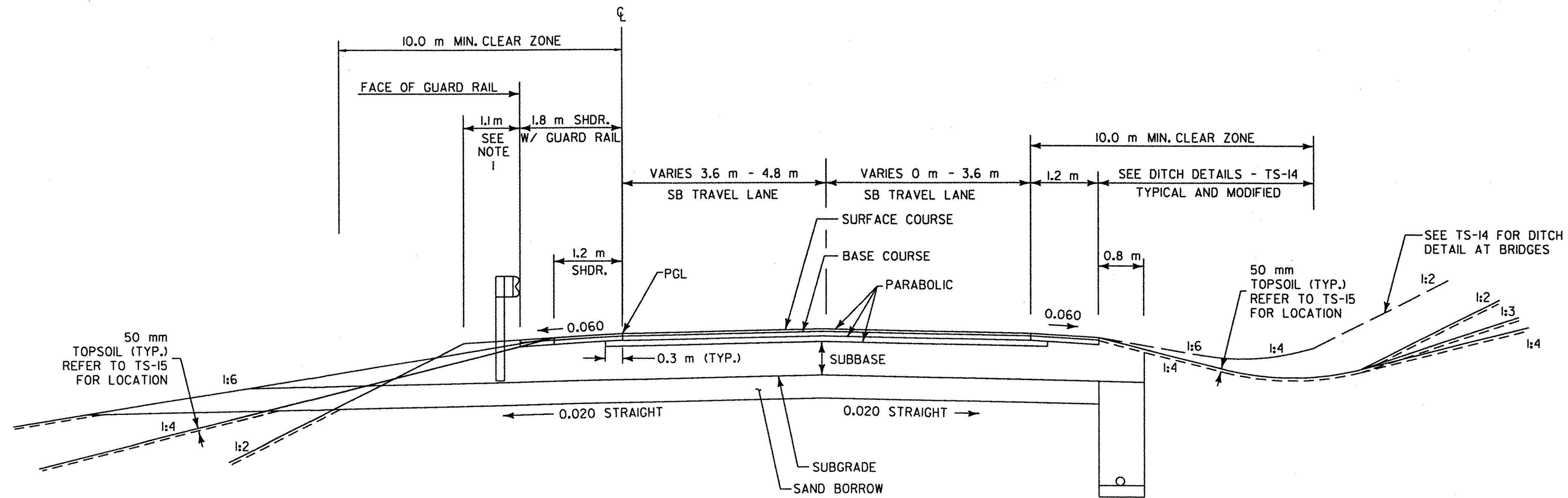

NORMAL SECTION

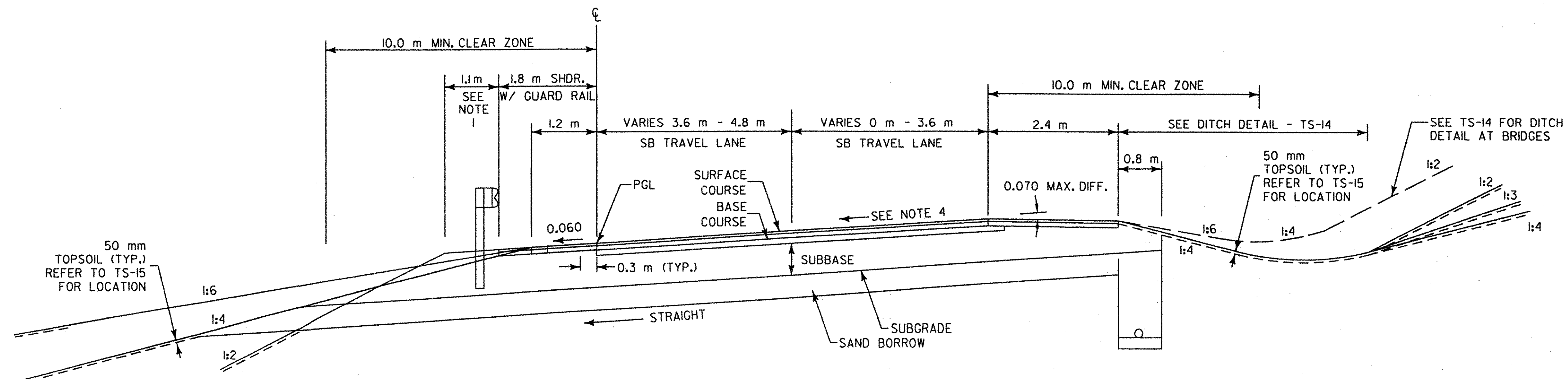

BANKED SECTION

SLOPE VARIES, SEE BANKING DIAGRAM ON PROFILE SHEETS.

VERMONT AGENCY OF TRANSPORTATION



PROJECT NAME: BENNINGTON
 PROJECT NUMBER: NH FO19-1(5)

REVISED

FILE NAME: ...Highway\PlotFiles\typicals.ptf PLOT DATE: 11/20/2004
 DESIGN SUPERVISOR: GREG EDWARDS DRAWN BY: DUFRESNE-HENRY
 DESIGNED BY: MARC FOISY CHECKED BY: GARY SANTY
TYPICAL TS-09 SHEET 12 OF 112

PGL = PROFILE GRADE LINE

K:\6380020 (Bennington)\Highway\PlotFiles\typicals.ppt

| MATERIAL ITEM | THICKNESS TOLERANCE |
|--------------------------------|---------------------|
| PAVEMENT COURSES (TOTAL DEPTH) | +/- 5 mm |
| BASE COURSES (TOTAL DEPTH) | +/- 15 mm |
| SUBBASE | +/- 30 mm |

TYPICAL SECTION CHAPEL ROAD

- 50 mm SUPERPAVE BITUMINOUS CONCRETE PAVEMENT, TYPE IIS
- 100 mm BASE COURSE, SUPERPAVE BITUMINOUS CONCRETE PAVEMENT, TYPE IS
- 450 mm SUBBASE OF DENSE GRADED CRUSHED STONE
- 300 mm SAND BORROW
- SHOULDERS: 50 mm BITUMINOUS CONCRETE PAVEMENT, TYPE IIS

NOTE:
1) DESIGN FROST DEPTH - 585 mm

- NOTES:**
- ELIMINATE TOPSOIL AND SEEDING BEHIND GUARD RAIL TO SUBGRADE CATCH POINT.
 - FOR SLOPES IN SOLID ROCK EXCAVATION AND DRILLING AND BLASTING OF SOLID ROCK SUBGRADE, SEE STD. SHEET A-60M AND A-62M AND DETAILS
 - REFER TO TYPICAL SECTION SHEET, TS-15 FOR SEEDING FORMULA AND ADDITIONAL GENERAL NOTES.
 - SEE BANKING DIAGRAM ON PROFILES FOR CROSS SLOPE

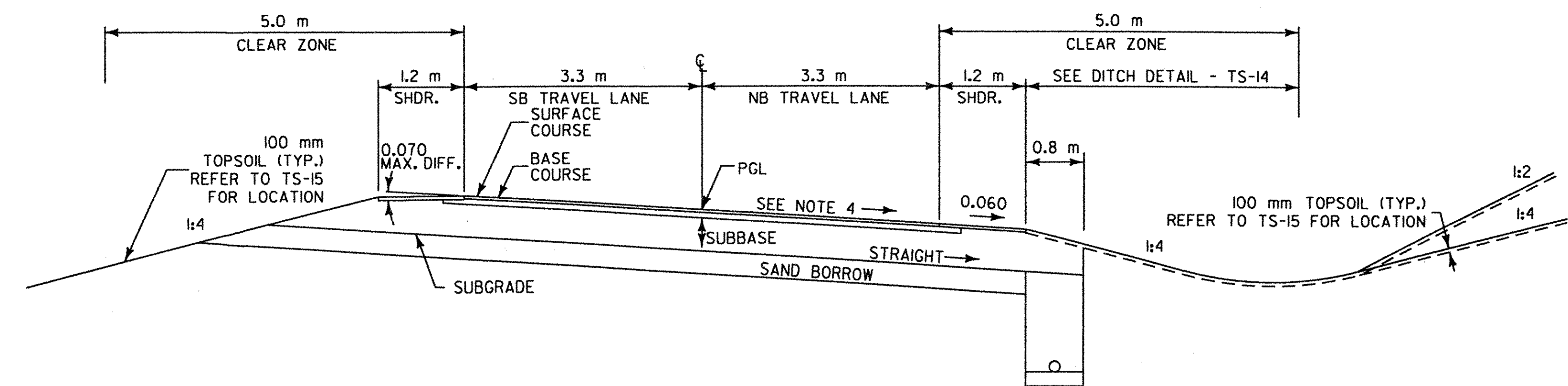
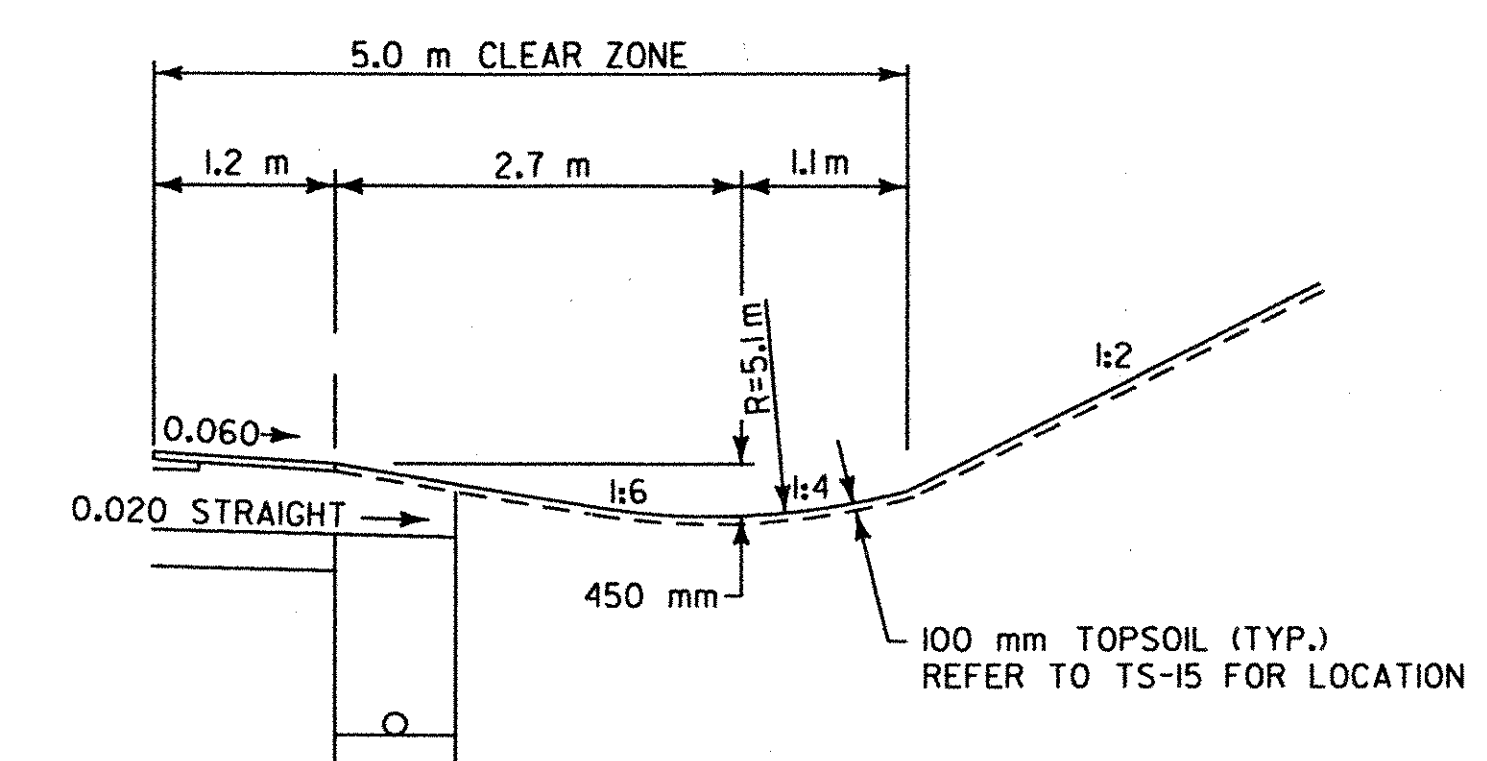
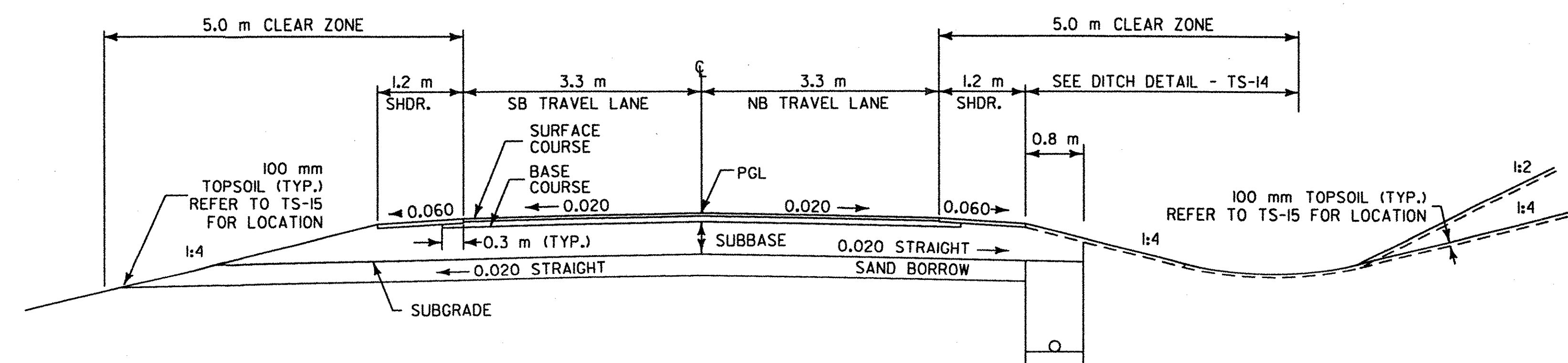

STA. CH 1+360 TO STA. CH 1+440, RT.

PGL=PROFILE GRADE LINE

| | |
|--|--|
| VERMONT AGENCY OF TRANSPORTATION | |
| DH Dufresne-Henry | PROJECT NAME: BENNINGTON PROJECT NUMBER: NH F019-1(5) REVISED |
| FILE NAME: ...Highway\PlotFiles\typicals.prf DESIGN SUPERVISOR: GREG EDWARDS DESIGNED BY: MARC FOISY | PLOT DATE: 11/20/2004 DRAWN BY: DUFRESNE-HENRY CHECKED BY: GARY SANTY SHEET 13 OF 112 |
| TYPICAL TS-10 | |



TYPICAL SECTION - EAST ROAD

| MATERIAL ITEM | THICKNESS TOLERANCE |
|--------------------------------|---------------------|
| PAVEMENT COURSES (TOTAL DEPTH) | +/- 5 mm |
| BASE COURSES (TOTAL DEPTH) | +/- 15 mm |
| SUBBASE | +/- 30 mm |
| SAND BORROW | +/- 30 mm |

| | |
|--------|--|
| 50 mm | SUPERPAVE BITUMINOUS CONCRETE PAVEMENT, TYPE III S |
| 100 mm | BASE COURSE, SUPERPAVE BITUMINOUS CONCRETE PAVEMENT, TYPE IS |
| 450 mm | SUBBASE OF DENSE GRADED CRUSHED STONE |
| 300 mm | SAND BORROW |

SHOULDERS: 50 mm BITUMINOUS CONCRETE PAVEMENT, TYPE III S

NOTE:
1) DESIGN FROST DEPTH - 585 MM

- NOTES:
- ELIMINATE TOPSOIL AND SEEDING BEHIND GUARD RAIL TO SUBGRADE CATCH POINT.
 - FOR SLOPES IN SOLID ROCK EXCAVATION AND DRILLING AND BLASTING OF SOLID ROCK SUBGRADE, SEE STD. SHEET A-60M AND A-62M AND DETAILS
 - REFER TO TYPICAL SECTION SHEET, TS-15 FOR SEEDING FORMULA AND ADDITIONAL GENERAL NOTES.
 - REFER TO STANDARD SHEET A-78M FOR ADDITIONAL DETAILS OF SHARED USE PATH CONSTRUCTION.
 - SEE BANKING DIAGRAM ON PROFILES FOR CROSS SLOPE

SHARED USE PATH

| | |
|--------|--|
| 50 mm | SUPERPAVE BITUMINOUS CONCRETE PAVEMENT, TYPE III S |
| 300 mm | SUBBASE OF DENSE GRADED CRUSHED STONE |

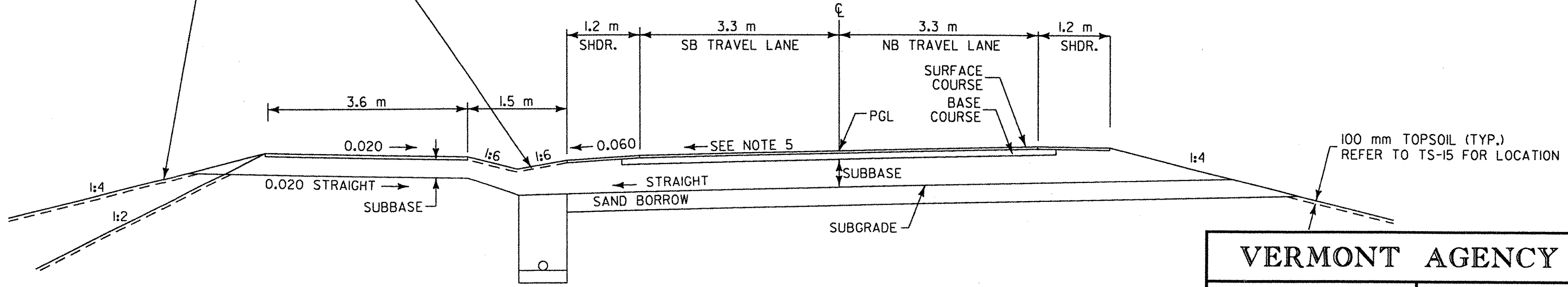
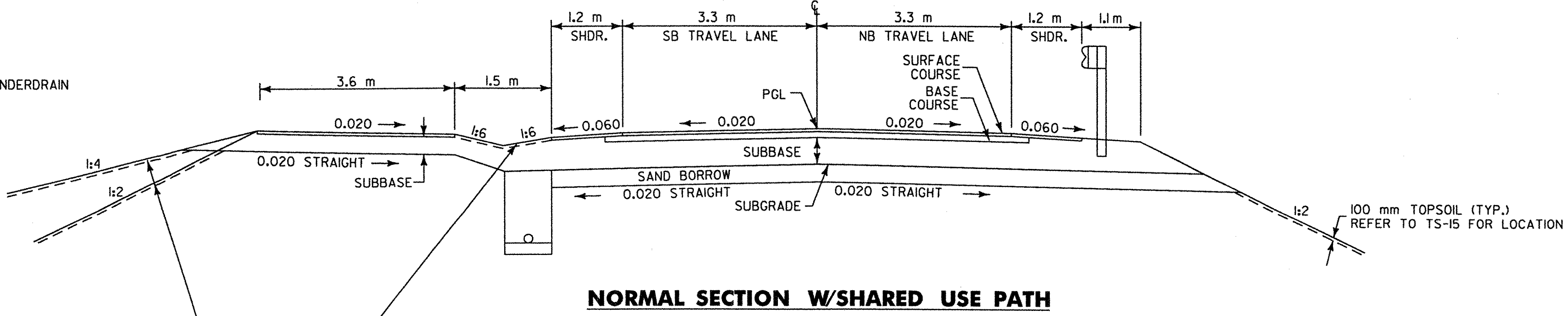
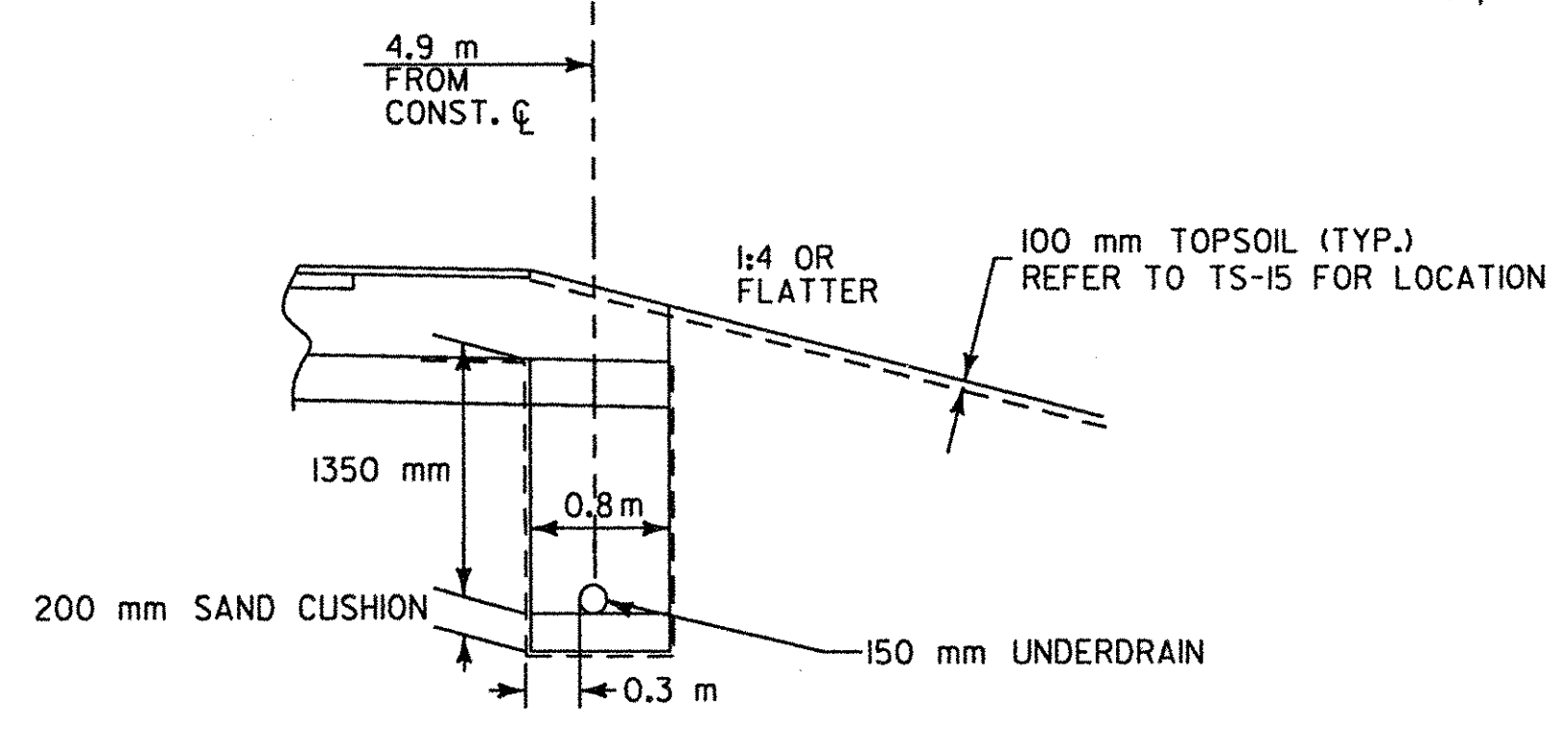
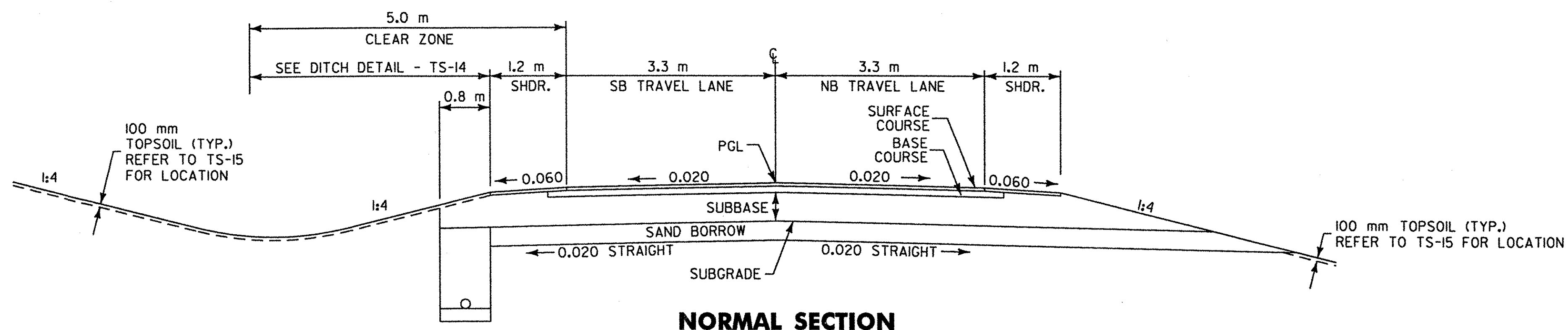

SLOPE VARIES, SEE BANKING DIAGRAM ON PROFILE SHEETS.

VERMONT AGENCY OF TRANSPORTATION

PROJECT NAME: BENNINGTON
PROJECT NUMBER: NH F019-K(5)

REVISED

FILE NAME: ...Highway\PlotFiles\typicals.pft PLOT DATE: 11/9/2004
DESIGN SUPERVISOR: GREG EDWARDS DRAWN BY: DUFRESNE-HENRY
DESIGNED BY: MARC FOISY CHECKED BY: GARY SANTY
TYPICAL TS-11 SHEET 14 OF 112

DH
Dufresne-Henry

PGL=PROFILE GRADE LINE

K:\A6380020_Benn\Highway\PlotFiles\typicals.pft

**TYPICAL SECTION
BALD MOUNTAIN TRAIL
QUARRY ACCESS DRIVE
VETERAN'S RESERVOIR DRIVE**

- NOTES:**
1. ELIMINATE TOPSOIL AND SEEDING BEHIND GUARD RAIL TO SUBGRADE CATCH POINT.
 2. FOR SLOPES IN SOLID ROCK EXCAVATION AND DRILLING AND BLASTING OF SOLID ROCK SUBGRADE, SEE VTrans STD. SHEET A-60M AND A-62M AND DETAILS
 3. REFER TO TYPICAL SECTION SHEET, TS-15 FOR SEEDING FORMULA AND ADDITIONAL GENERAL NOTES.

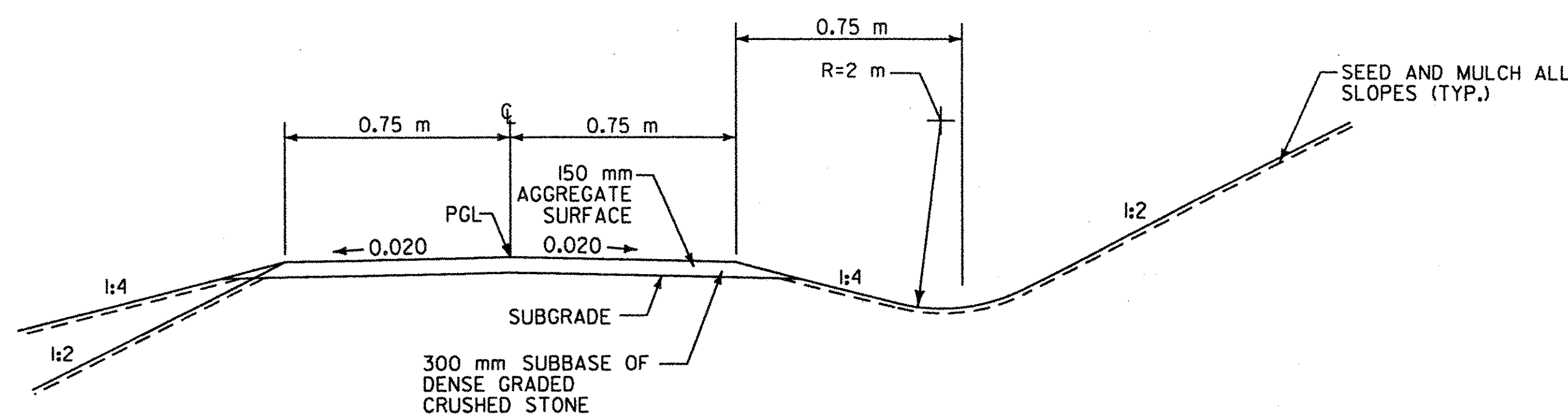

BALD MOUNTAIN TRAIL

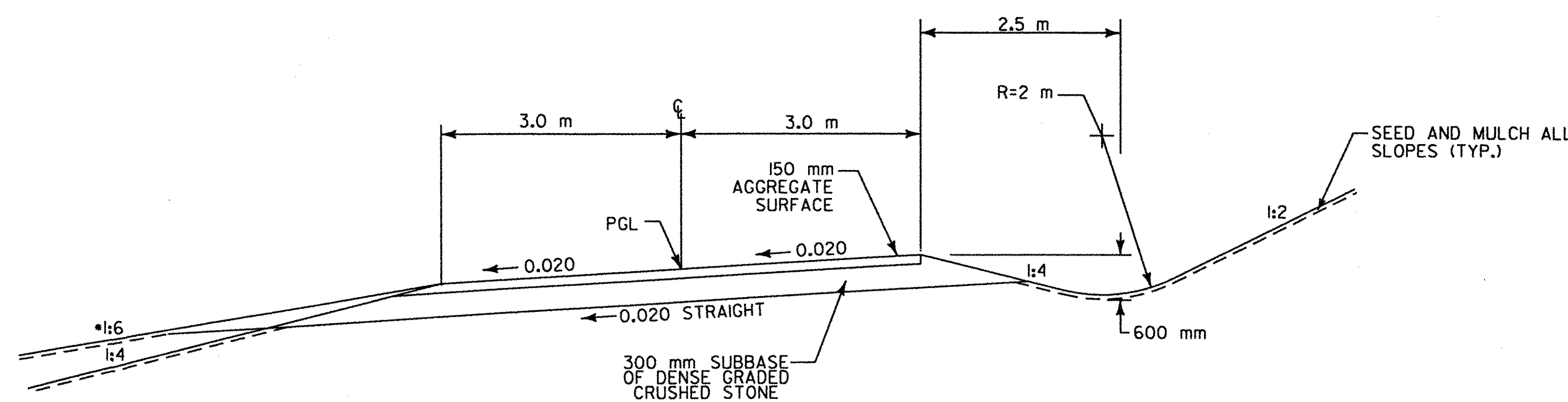

*SIDESLOPES AT THE INTERSECTION (DITCHLINE) OF CHAPEL ROAD TO BE 1:6 OR FLATTER IN ACCORDANCE WITH STANDARD B-71M.

QUARRY ACCESS DRIVE

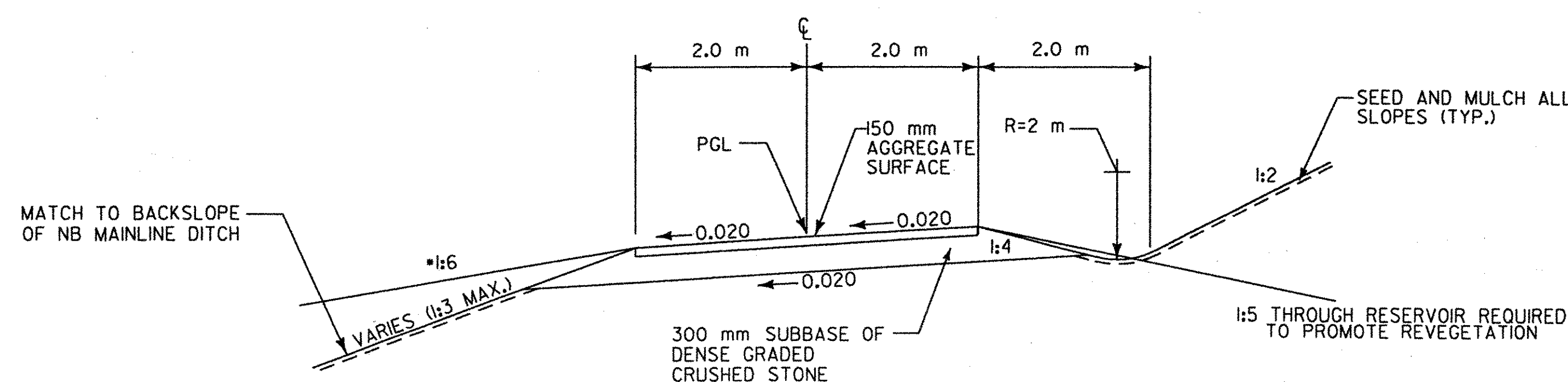

*SIDESLOPES AT THE INTERSECTION (DITCHLINE) OF MAINLINE TO BE 1:6 OR FLATTER IN ACCORDANCE WITH STANDARD B-71M.

VETERAN'S RESERVOIR ACCESS DRIVE

PGL=PROFILE GRADE LINE

VERMONT AGENCY OF TRANSPORTATION



PROJECT NAME: BENNINGTON
PROJECT NUMBER: NH F019-K(5)

REVISED

FILE NAME: ...Highway\PlotFiles\typicals.pff
DESIGN SUPERVISOR: GREG EDWARDS
DESIGNED BY: MARC FOISY

PLOT DATE: 11/20/2004
DRAWN BY: DUFRESNE-HENRY
CHECKED BY: GARY SANTY
SHEET 15 OF 112

TYPICAL TS-12

TYPICAL SECTION-VT ROUTE 9



| MATERIAL ITEM | THICKNESS TOLERANCE |
|--------------------------------|---------------------|
| PAVEMENT COURSES (TOTAL DEPTH) | +/- 5 mm |
| BASE COURSES (TOTAL DEPTH) | +/- 15 mm |
| SUBBASE | +/- 30 mm |
| SAND BORROW | +/- 30 mm |

| | |
|------------------|---|
| 90 mm | BITUMINOUS CONCRETE PAVEMENT (40 mm TYPE IIS, 50 mm TYPE IIS) |
| 100 mm | BASE COURSE, BITUMINOUS CONCRETE PAVEMENT, TYPE IS |
| 600 mm | SUBBASE OF DENSE GRADED CRUSHED STONE |
| 400 mm | SAND BORROW |
| SHOULDERS: 90 mm | BITUMINOUS CONCRETE PAVEMENT (40 mm TYPE IIS, 50 mm TYPE IIS) |
| 100 mm | BASE COURSE, BITUMINOUS CONCRETE PAVEMENT, TYPE IS |

NOTE:
1) DESIGN FROST DEPTH - 1170 MM

- NOTES:
1. ELIMINATE TOPSOIL AND SEEDING BEHIND GUARD RAIL TO SUBGRADE CATCH POINT.
 2. FOR SLOPES IN SOLID ROCK EXCAVATION AND DRILLING AND BLASTING OF SOLID ROCK SUBGRADE, SEE STD. SHEET A-60M AND DETAILS
 3. REFER TO TYPICAL SECTION SHEET, TS-15 FOR SEEDING FORMULA AND ADDITIONAL GENERAL NOTES.

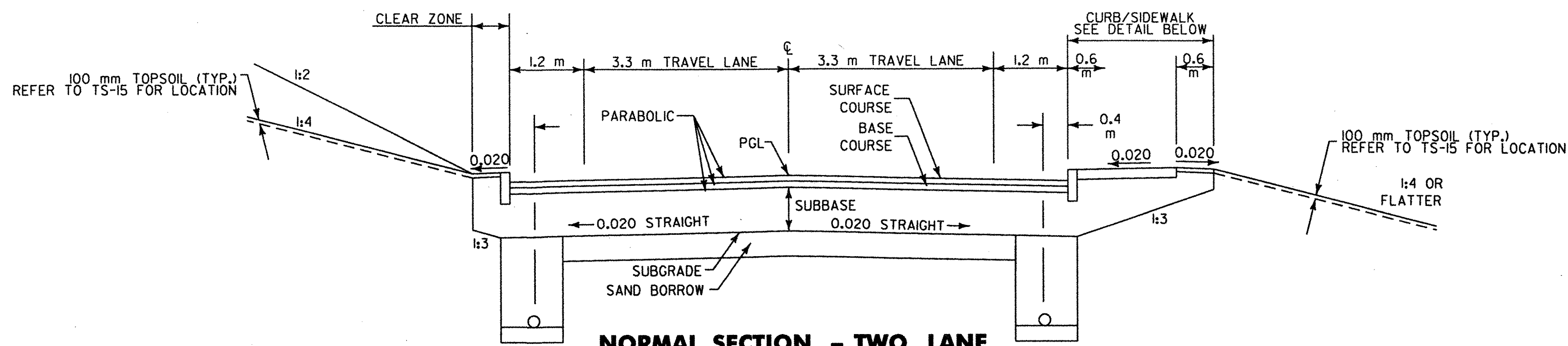

NORMAL SECTION - TWO LANE

STA. VT 1+260 - STA. VT 1+275

STA. VT 1+600 - STA. VT 1+660

BETWEEN THESE STATIONS THE SIDEWALK IS LOCATED ON THE RIGHT SIDE

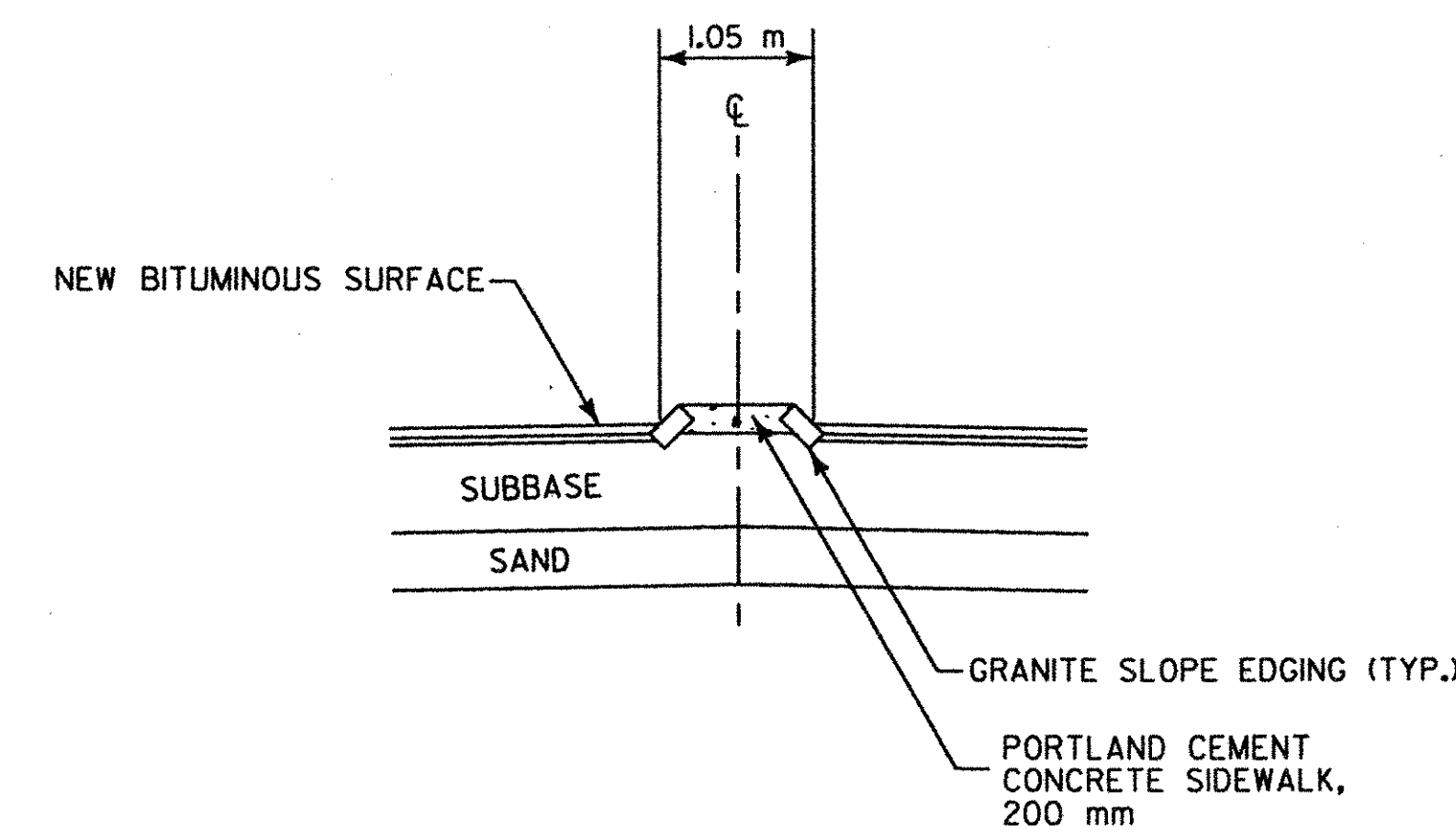

RAISED ISLAND DETAIL

VT 1+428.8 - VT 1+444.8

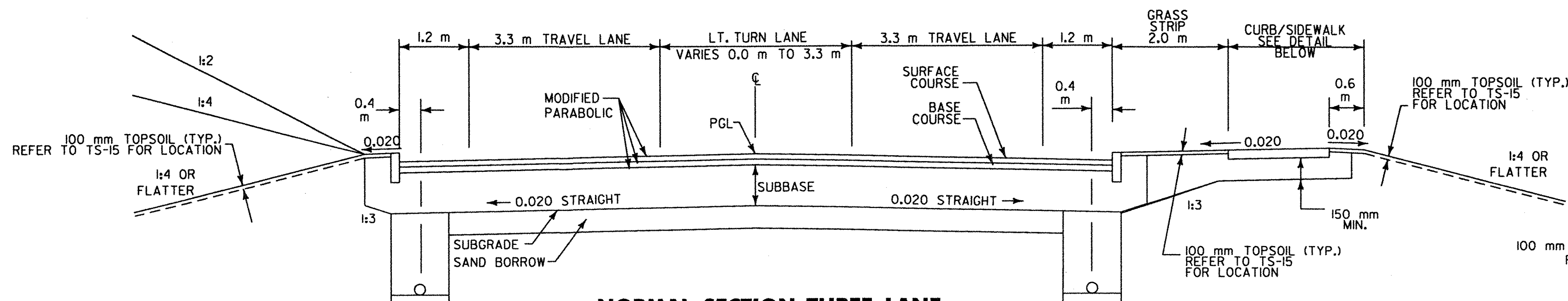

NORMAL SECTION-THREE LANE

STA. VT 1+275 - STA. VT 1+600

AT STATION VT 1+460 THE SIDEWALK SWITCHES TO THE RIGHT SIDE

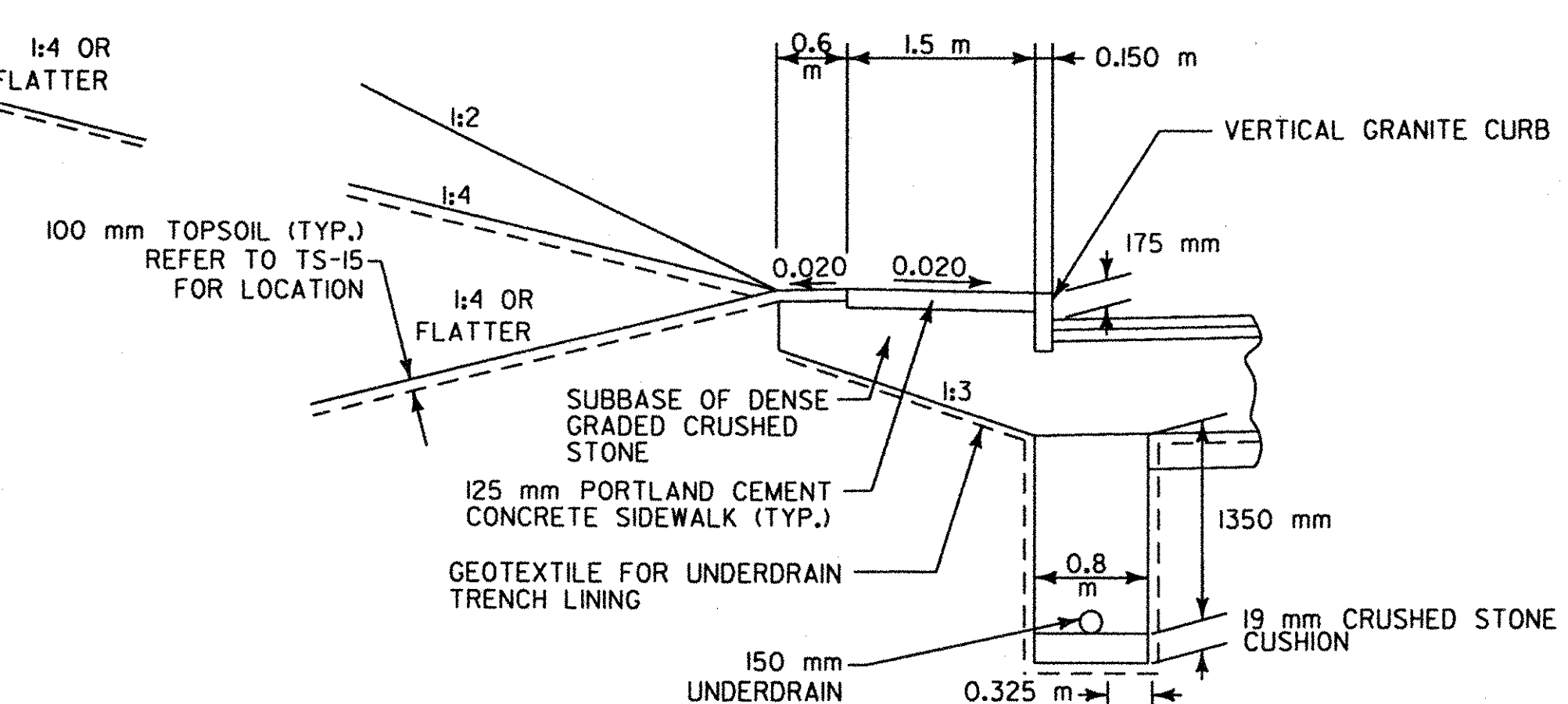

TYPICAL UNDERDRAIN, CURB AND SIDEWALK (ADJACENT TO CURB) DETAIL

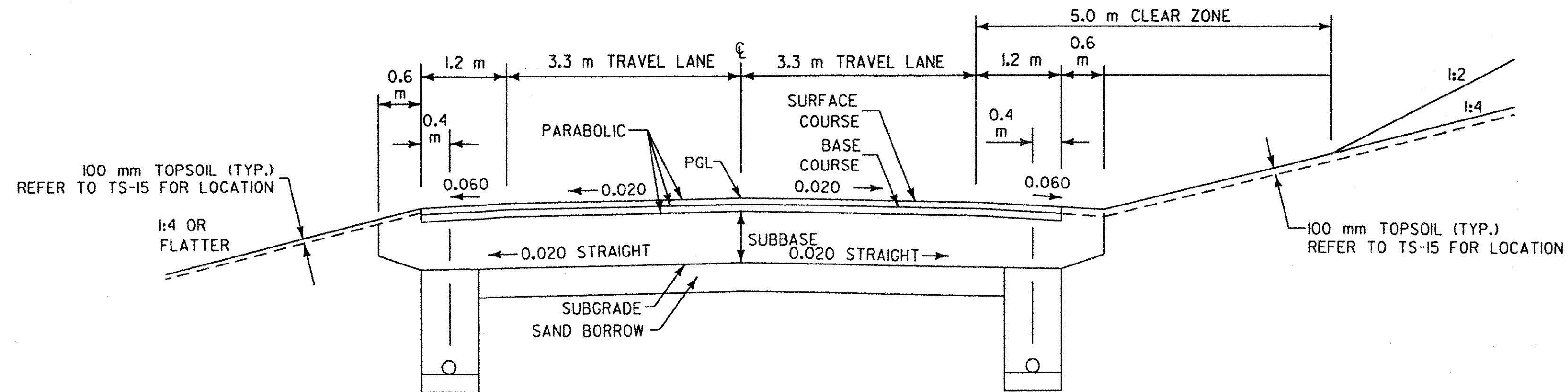

NORMAL SECTION - WITHOUT CURB

STA. VT 1+660 - STA. VT 1+819.500

PGL=PROFILE GRADE LINE

VERMONT AGENCY OF TRANSPORTATION

PROJECT NAME: BENNINGTON
PROJECT NUMBER: NH FO19-1(5)

REVISED

FILE NAME: ...Highway\PlotFiles\typicals.pff PLOT DATE: 11/20/2004
DESIGN SUPERVISOR: GREG EDWARDS DRAWN BY: DUFRESNE-HENRY
DESIGNED BY: MARC FOISY CHECKED BY: GARY SANTY
TYPICAL TS-13 SHEET 16 OF 112



K:\538020 (Berm)\Highway\PlotFiles\typicals.pff

| TOPSOIL LOCATIONS | | | |
|-------------------|-------------|------------|-------------|
| BEGIN STATION | END STATION | LOCATION | DEPTH |
| NB 10+100 | NB 10+780 | RIGHT | SEE TYPICAL |
| CN 10+300 | CN 2+660 | LEFT/RIGHT | SEE TYPICAL |
| A 1+040 | A 1+240 | LEFT/RIGHT | SEE TYPICAL |
| D 1+040 | D 1+230 | LEFT/RIGHT | SEE TYPICAL |
| E 1+240 | E 1+320 | RIGHT | SEE TYPICAL |
| F 1+040 | F 1+180 | LEFT | SEE TYPICAL |
| G 1+040 | G 1+230 | LEFT | SEE TYPICAL |
| P 1+000 | P 1+080 | LEFT/RIGHT | SEE TYPICAL |
| Q 1+030 | Q 1+120 | LEFT/RIGHT | SEE TYPICAL |
| R 1+500 | R 1+590 | LEFT/RIGHT | SEE TYPICAL |
| S 1+000 | S 1+080 | LEFT/RIGHT | SEE TYPICAL |
| VT 1+200 | VT 1+820 | LEFT/RIGHT | SEE TYPICAL |
| CH 1+230 | CH 1+460 | LEFT/RIGHT | SEE TYPICAL |
| ER 0+950 | EA 1+345 | LEFT/RIGHT | SEE TYPICAL |

TYPICAL SECTIONS MISCELLANEOUS DETAILS

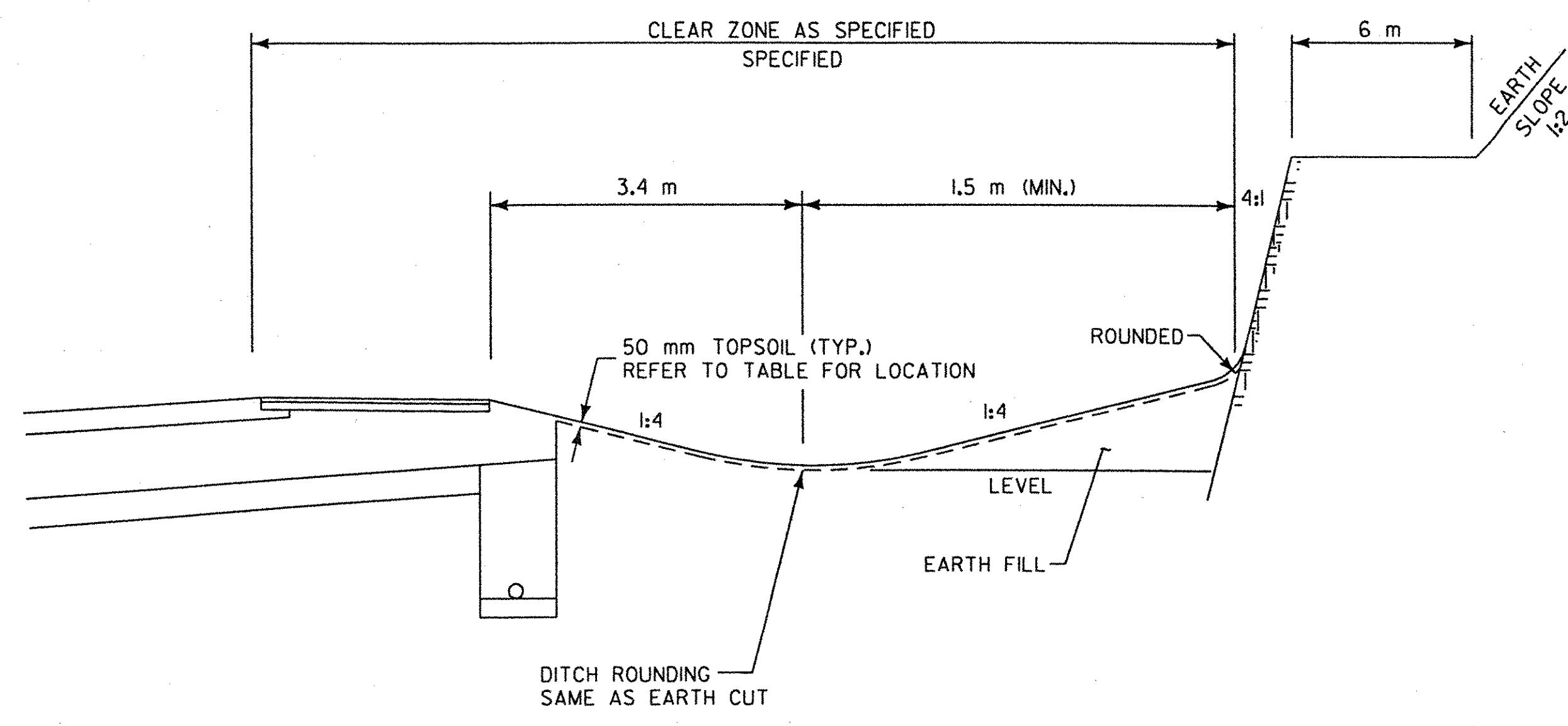

LEDGE CUT DETAIL

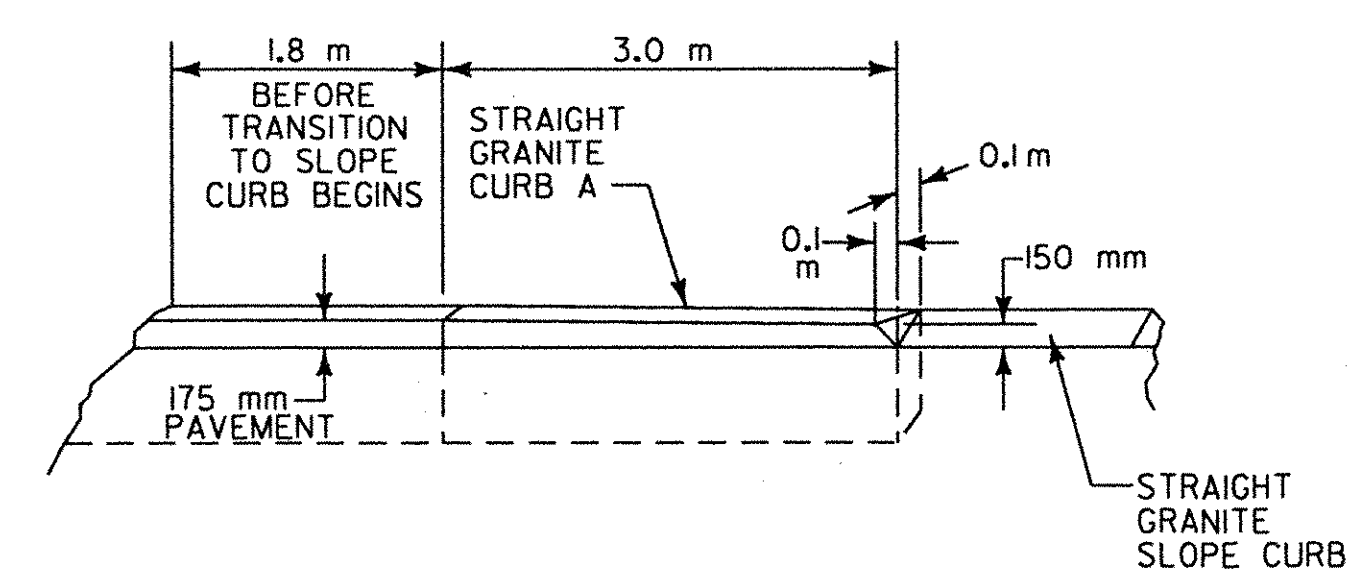

SLOPE CURB TO VERTICAL CURB TRANSITION DETAIL

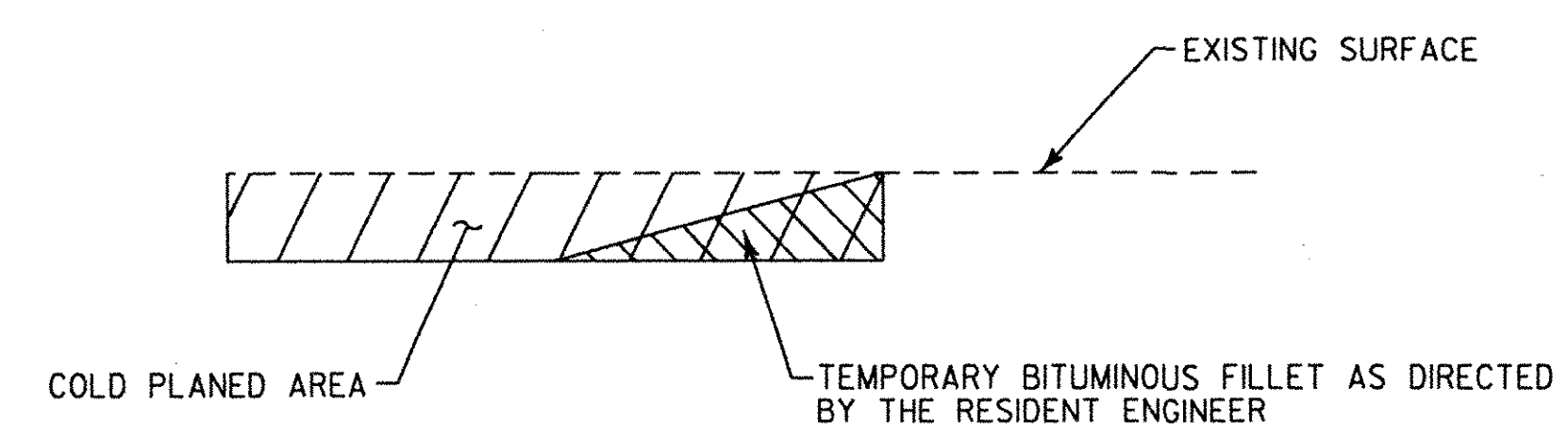

DETAIL AT VERTICAL COLD PLANE JOINTS

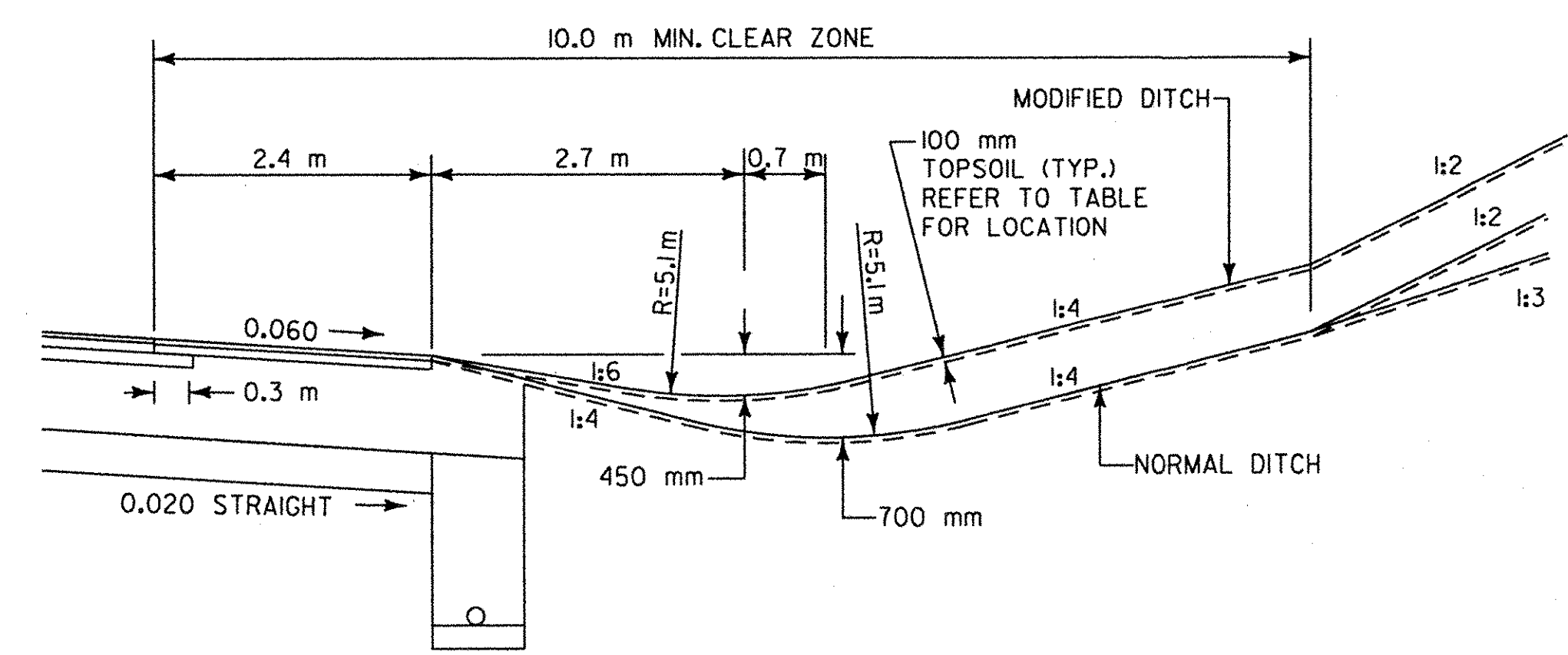

**MODIFIED DITCH SECTION
NB 9+245 TO NB 9+300 RT.
CD 1+750 TO 1+900 LT.**

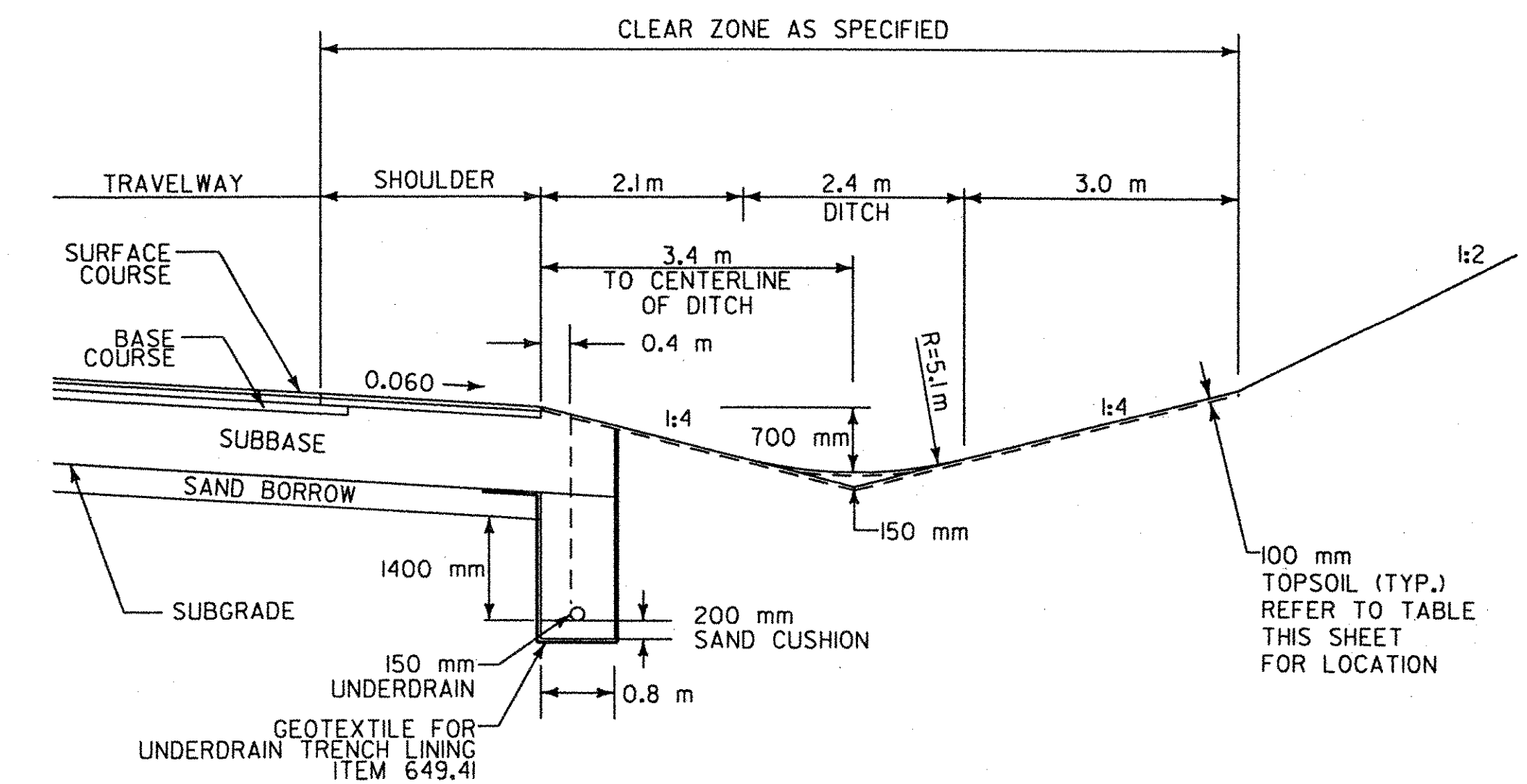

**TYPICAL UNDERDRAIN AND DITCH DETAIL
8.8-10.0 m CLEAR ZONE**

VERMONT AGENCY OF TRANSPORTATION

DH
Dufresne-Henry

PROJECT NAME: BENNINGTON
PROJECT NUMBER: NH FO19-1(5)

REVISED

FILE NAME: ...Highway\PlotFiles\typicals.pff
DESIGN SUPERVISOR: GREG EDWARDS
DESIGNED BY: MARC FOISY

PLOT DATE: 11/23/2004
DRAWN BY: DUFRESNE-HENRY
CHECKED BY: GARY SANTY

TYPICAL TS-14
SHEET 17 OF 112

K:\ASB0020 (benn)\Highway\PlotFiles\Typicals.pff

PGL=PROFILE GRADE LINE

**SEEDING FORMULA ITEM 651.15
RURAL AREAS**

| MASS | KA/HA | NAME | PUR % | GERM % |
|-------|-------|---------------------|-------|--------|
| 37.14 | 26.0 | CREeping RED FESCUE | 98 | 85 |
| 37.14 | 26.0 | TALL FESCUE | 95 | 90 |
| 5.71 | 4.0 | RED TOP | 95 | 90 |
| 14.30 | 10.0 | BIRDFOOT TREFOIL | 98 | 85 |
| 5.71 | 4.0 | ANNUAL RYEGRASS | 95 | 85 |

URBAN AREAS CONSERVATION MIX

| MASS | KA/HA | NAME | PUR % | GERM % |
|------|-------|---------------------|-------|--------|
| 42.2 | 38.0 | CREeping RED FESCUE | 98 | 85 |
| 10.0 | 9.0 | PERENNIAL RYEGRASS | 95 | 90 |
| 42.2 | 38.0 | KENTUCKY BLUEGRASS | 85 | 85 |
| 5.6 | 5.0 | ANNUAL RYEGRASS | 95 | 85 |

SEEDING NOTES

THE SEED MIXTURE SHALL NOT HAVE A WEED CONTENT EXCEEDING 0.40% BY MASS AND SHALL BE FREE OF ALL NOXIOUS WEED SEED.
SEED TO BE APPLIED PER SEEDING FORMULA AS DIRECTED BY THE ENGINEER.
FERTILIZER: FORMULA 10-20-10 TO BE USED WITH SEED, APPLIED AT RATE OF 560 KG/HA. (HYDRO SEEDERS MAY USE 19-19-19 FORMULA).
AGRICULTURAL LIMESTONE TO BE APPLIED AT THE RATE OF 4500 Kg/Ha OR AS DIRECTED BY THE ENGINEER.
HAY MULCH TO BE PLACED ON EARTH SLOPES AT THE RATE OF 4500 Kg/Ha OR AS DIRECTED BY THE ENGINEER.
TOPSOIL TO BE USED WITH SEED AS INDICATED ON THE PLANS OR AS DIRECTED BY THE ENGINEER.

GENERAL NOTES

THE SUPERPAVE BITUMINOUS CONCRETE PAVEMENT WEARING COURSE SHALL BE TYPE III'S. THE ESTIMATED 15 mm LEVELING COURSE SHALL BE TYPE IV'S UNLESS OTHERWISE DIRECTED BY THE ENGINEER. ALL ASPHALT CEMENT USED IN THE SUPERPAVE BITUMINOUS CONCRETE PAVEMENT SHALL BE PG 58-28.
GRASS GROWING ADJACENT TO EXISTING PAVEMENT OR THROUGH CRACKS IN THE EXISTING PAVEMENT WHICH MAY HAMPER THE PLACEMENT OF NEW SUPERPAVE BITUMINOUS CONCRETE PAVEMENT SHALL BE REMOVED BY THE CONTRACTOR AS DIRECTED BY THE ENGINEER. PAYMENT FOR THIS WORK WILL NOT BE MADE DIRECTLY, BUT WILL BE CONSIDERED SUBSIDIARY TO ITEM 490.30, SUPERPAVE BITUMINOUS CONCRETE PAVEMENT.
EMULSIFIED ASPHALT TO BE APPLIED ON EXISTING PAVEMENT, BETWEEN ALL COURSES OF SUPERPAVE BITUMINOUS CONCRETE PAVEMENT AND ON COLD PLANNED SURFACES, AT THE RATE OF 0.12 L/m² OR AS DIRECTED BY THE ENGINEER.
COLD PLANING TO BE COMPLETED ACCORDING TO THE TYPICAL OR AS OTHERWISE NOTED ON THE PLANS. THE COLD PLANING SHALL MATCH THE EXISTING CONDITIONS AT THE BEGINNING OF THE ROUTE 7 CONNECTOR AND BOTH ENDS OF THE NORTHBOUND COLD PLANE AREA AT THE NORTHERLY END OF THE PROJECT BY THE USE OF A VERTICAL BUTT JOINT. SEE DETAIL ON TS-14.
COLD PLANE GRINDINGS SHALL REMAIN THE PROPERTY OF THE STATE OF VERMONT UNLESS OTHERWISE DIRECTED BY THE ENGINEER.
ITEM 616.47, BITUMINOUS CONCRETE GUTTERS AND TRAFFIC ISLANDS WILL BE PAID ONLY WHERE SPECIFIED IN THE ITEM DETAIL SUMMARY SHEET. ALL OTHER BITUMINOUS CONCRETE PAVEMENT WORK, WHICH COULD INVOLVE SOME HAND-WORK (SUCH AS U-TURN, RAMPS AND AROUND DRAINAGE/UTILITY STRUCTURES) SHALL BE PAID FOR AT THE CONTACT UNIT PRICE FOR ITEM 490.30 SUPERPAVE BITUMINOUS CONCRETE PAVEMENT.
SLOPE ROUNDING --ALL CUT SLOPES TO BE ROUNDED IN ACCORDANCE WITH STANDARD SHEET B-5M
PAY LIMITS OF SAND BORROW WHEN USED IN CONJUNCTION WITH UNDERDRAIN - DETAIL ON SHEET TS-14.
MARKER POSTS TO BE PLACED AS DIRECTED BY THE ENGINEER.

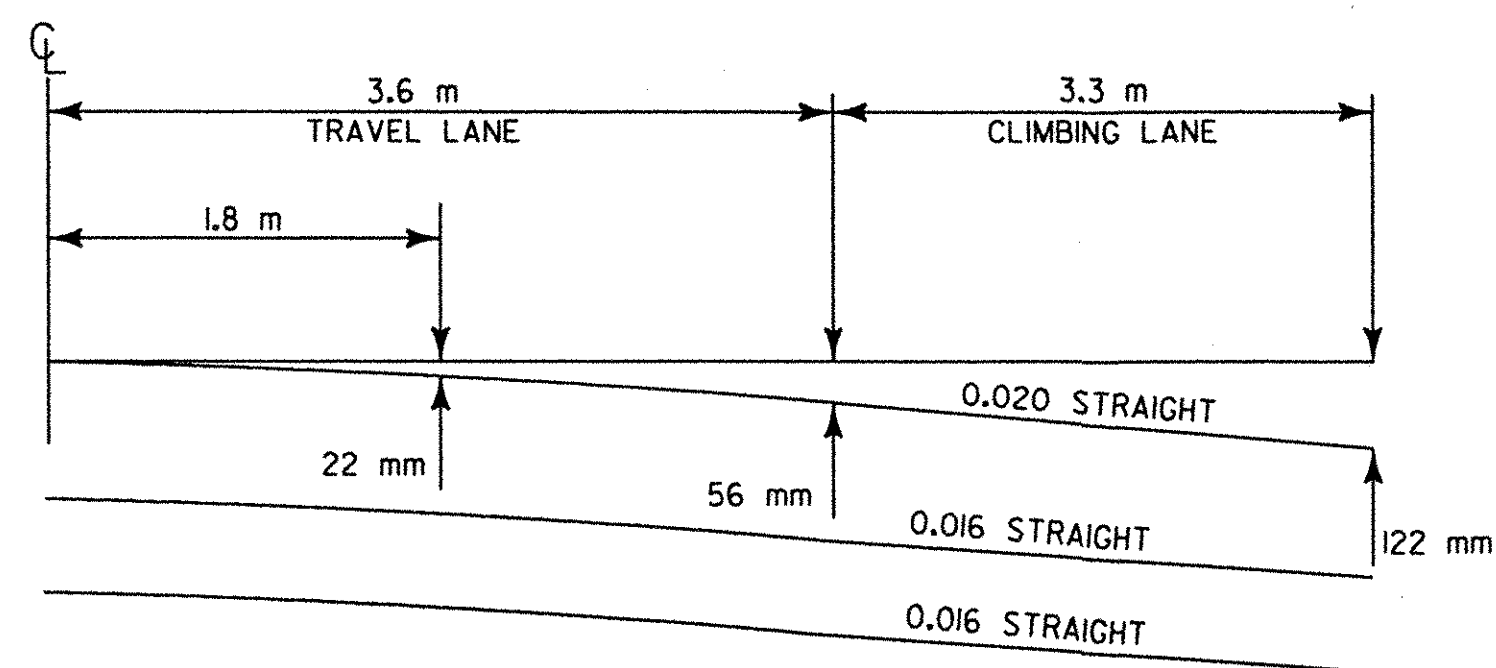

**MODIFIED PARABOLIC DETAIL
NORMAL SECTION WITH CLIMBING LANE
N.T.S.**

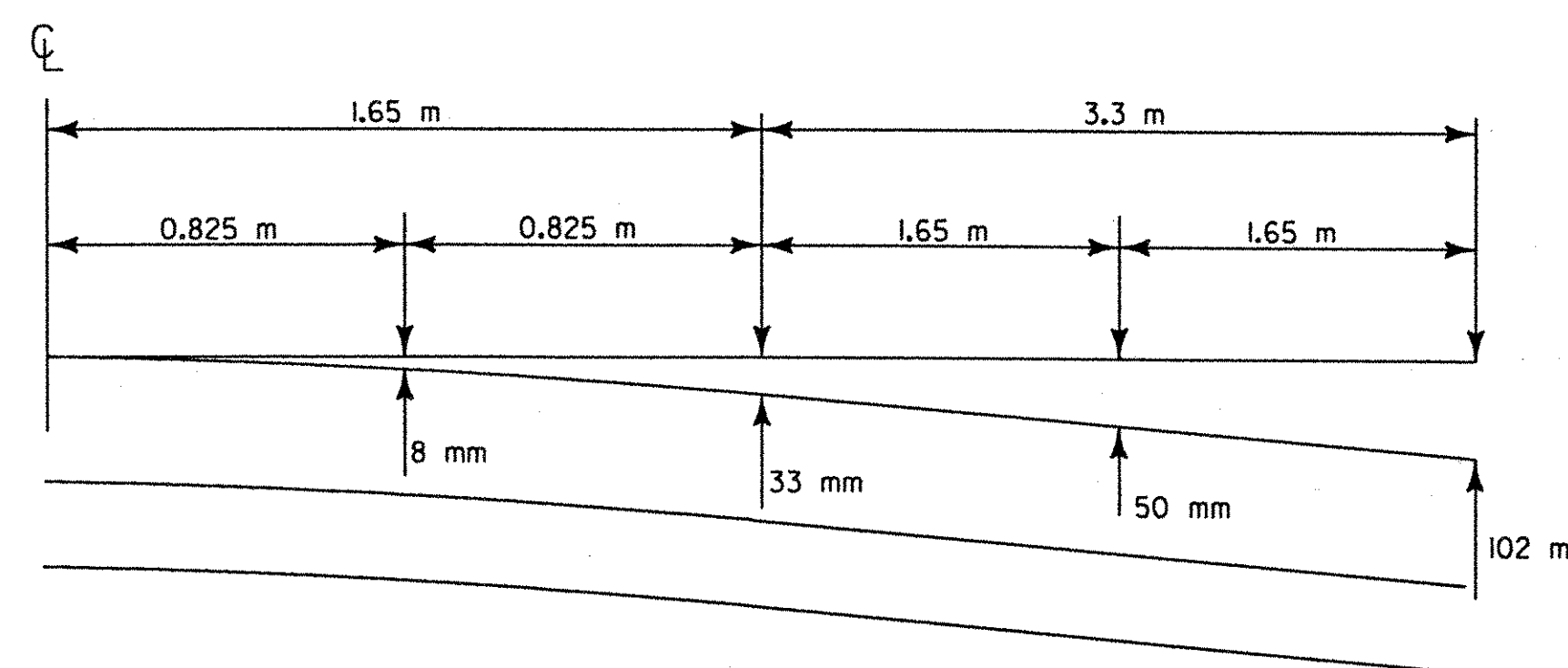

**MODIFIED PARABOLIC DETAIL
FOR LEFT TURN LANE
N.T.S.**

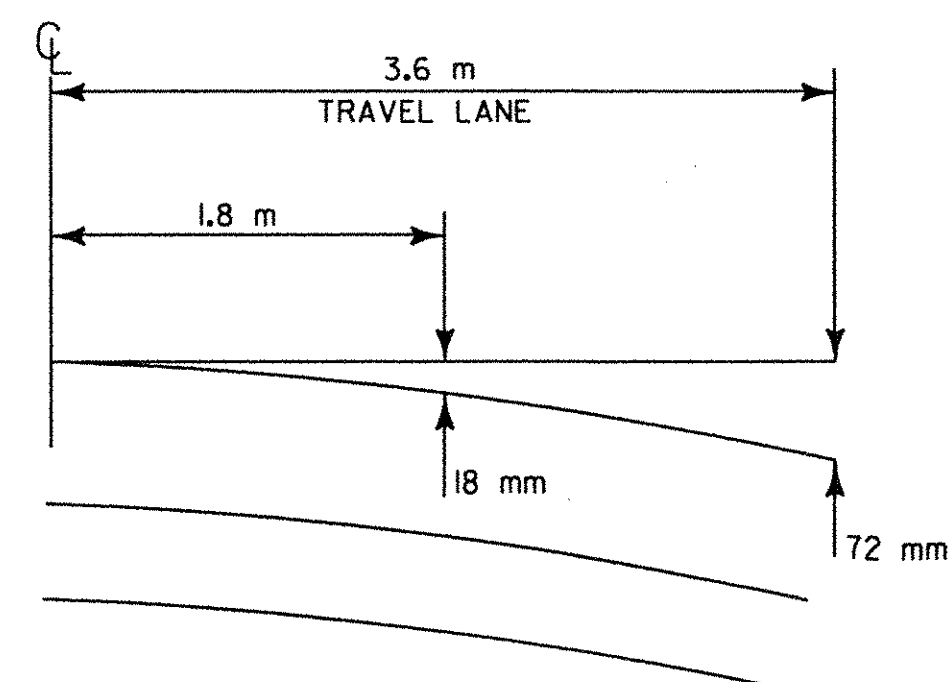

**PARABOLIC DETAIL
NORMAL SECTION
N.T.S.**

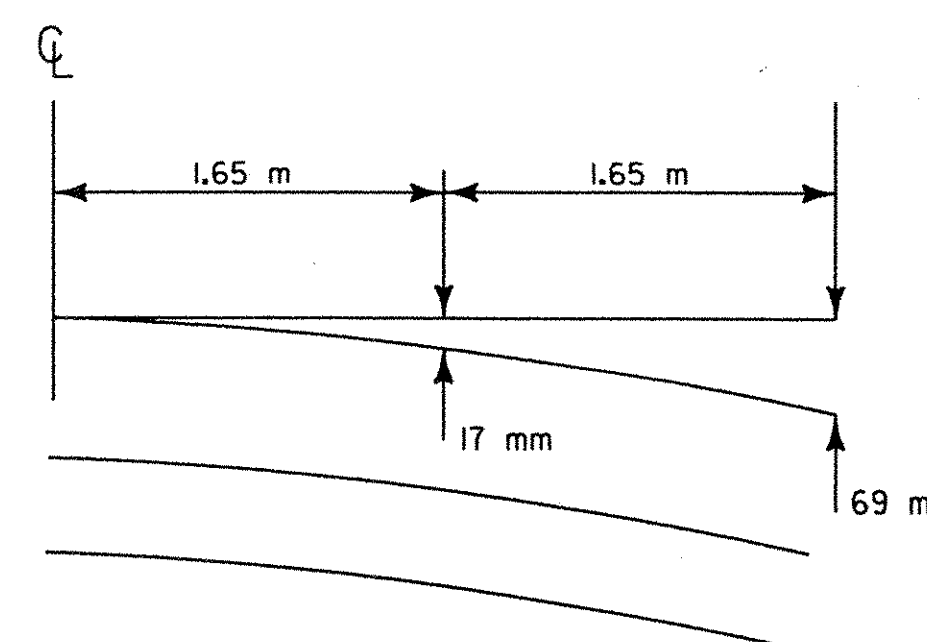

**PARABOLIC DETAIL
3.3 m LANE
N.T.S.**

PGL=PROFILE GRADE LINE

VERMONT AGENCY OF TRANSPORTATION



PROJECT NAME: BENNINGTON
PROJECT NUMBER: NH FO19-1(5)

REVISED

FILE NAME: ...Highway\PlotFiles\typicals.ptf PLOT DATE: 11/23/2004
DESIGN SUPERVISOR: GREG EDWARDS DRAWN BY: DUFRESNE-HENRY
DESIGNED BY: MARC FOISY CHECKED BY: GARY SANTY
TYPICAL TS-15 SHEET 18 OF 112

MAINLINE TIE DATA



NORTH IS COMMON TO ALL INSERTS

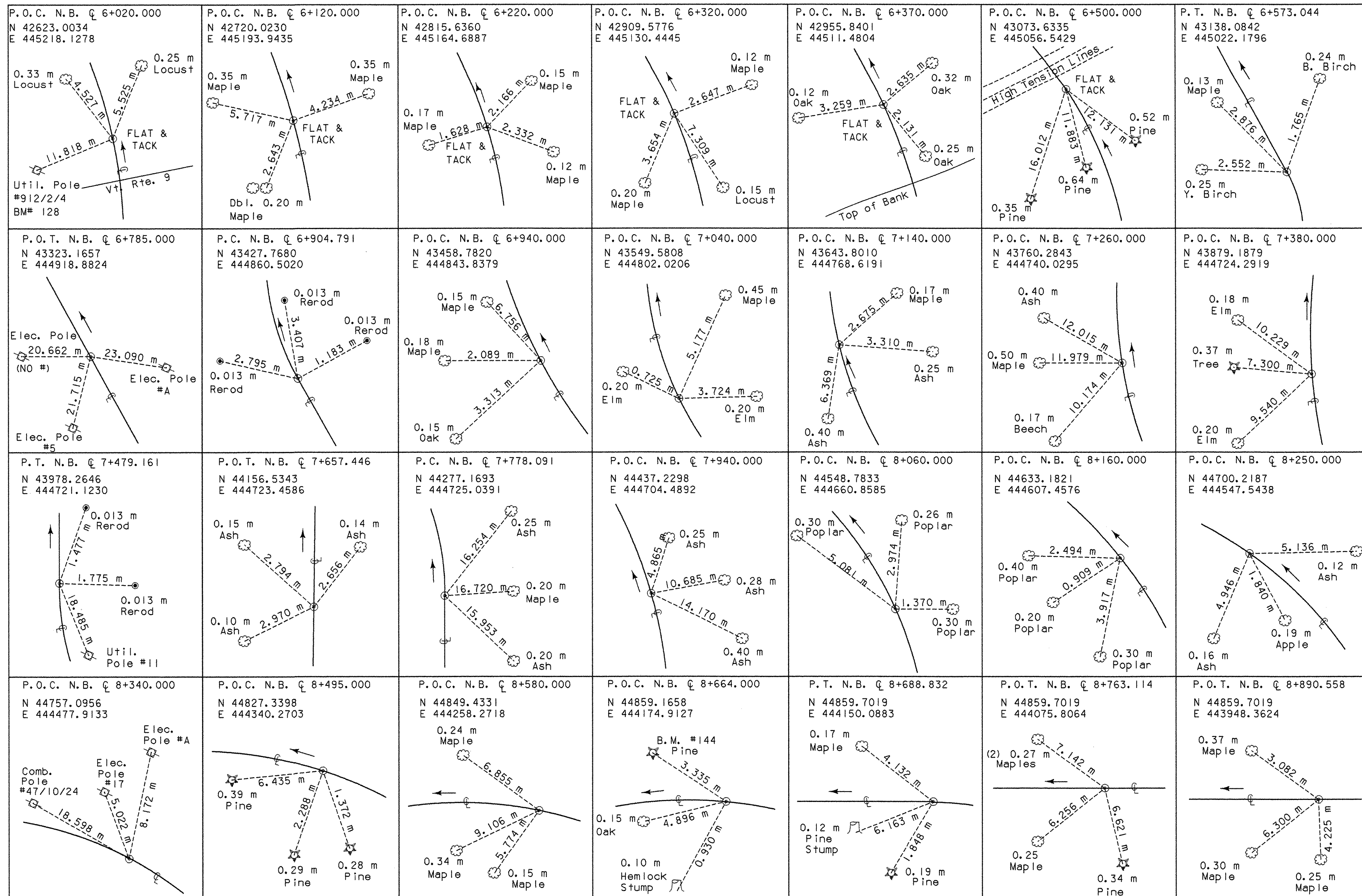
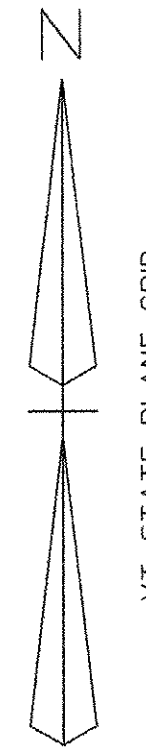

| | | |
|-------------------------------|--|----------------------------------|
| CONTROL TIE SHEET CT-1 | PROJECT NAME: BENNINGTON BYPASS | PROJECT NUMBER: NH FO19-I(5) |
| | DESIGN FILE NAME: c:\dh\bennington\row | PLOT DATE: 07-28-05 |
| | PROJECT LEADER: JDP | DRAWN BY: MBB CHECKED BY: GAK |
| SHEET: 19 OF 112 | | |

SIDE ROAD TIE DATA

NORTH IS COMMON TO ALL INSERTS

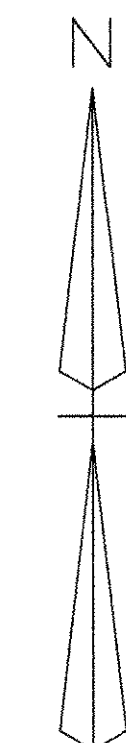

| | | | | | | |
|--|---|---|--|--|---|--|
| <p>P.O.T. N.B. C 8+988.559 N 44859.7019 E 443850.3614</p> | <p>P.O.T. N.B. C 9+260.000 N 44859.7019 E 443578.9204</p> | <p>P.C. N.B. C 9+306.755 (Old N.B. C) N 44860.1597 E 443532.1685</p> | <p>P.T. N.B. C 9+458.599 (Old N.B. C) N 44867.9010 E 443380.5482</p> | <p>P.O.T. N.B. C 9+823.616 (Old N.B. C) N 44911.7276 E 443018.1979</p> | <p>P.O.T. N.B. C 10+196.334 (Old N.B. C) N 44958.7642 E 442648.4598</p> | |
| <p>CHP P.C. C 1+311.646 N 44692.4025 E 444456.7224</p> | <p>CHP P.O.C. C 1+383.546= NB P.O.C. M 8+350.609 N 44763.0636 E 444469.1418</p> | <p>CHP P.T. C 1+385.090 N 44764.5435 E 444469.5841</p> | | | | |
| <p>PRK P.O.T. C 1+000.000 (old) N 44673.6761 E 443503.1875</p> | <p>PRK P.C. C 1+092.259 (old) N 44759.8565 E 443535.9799</p> | <p>PRK P.O.C. C 1+195.363 (old)= NB P.O.T. M 9+277.377 N 44859.8966 E 443560.6320</p> | <p>PRK P.T. C 1+208.753 (old) N 44873.0962 E 443562.8815</p> | <p>PRK P.O.T. C 1+362.833 (old) N 45025.9140 E 443582.5172</p> | | |

**CONTROL
TIE
SHEET
CT-2**

PROJECT NAME:
BENNINGTON BYPASS
DESIGN FILE NAME: c:\dh\bennington\row
PROJECT LEADER: JDP

PROJECT NUMBER:
NH F019-1(5)

PLOT DATE: 07-28-05
DRAWN BY: MBB
CHECKED BY: GAK

SHEET: 20 OF 112

G.P.S. TIE DATA

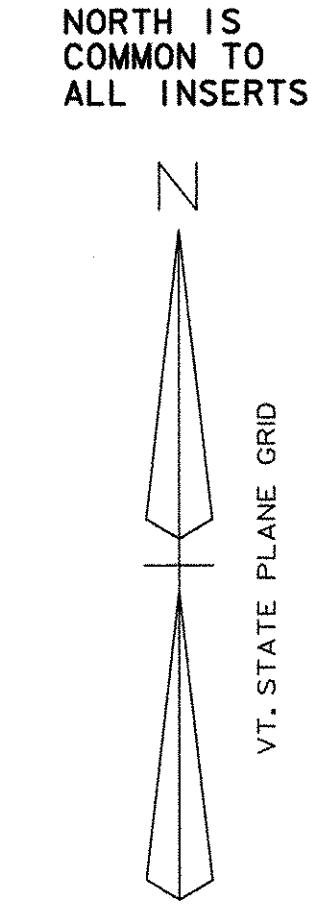
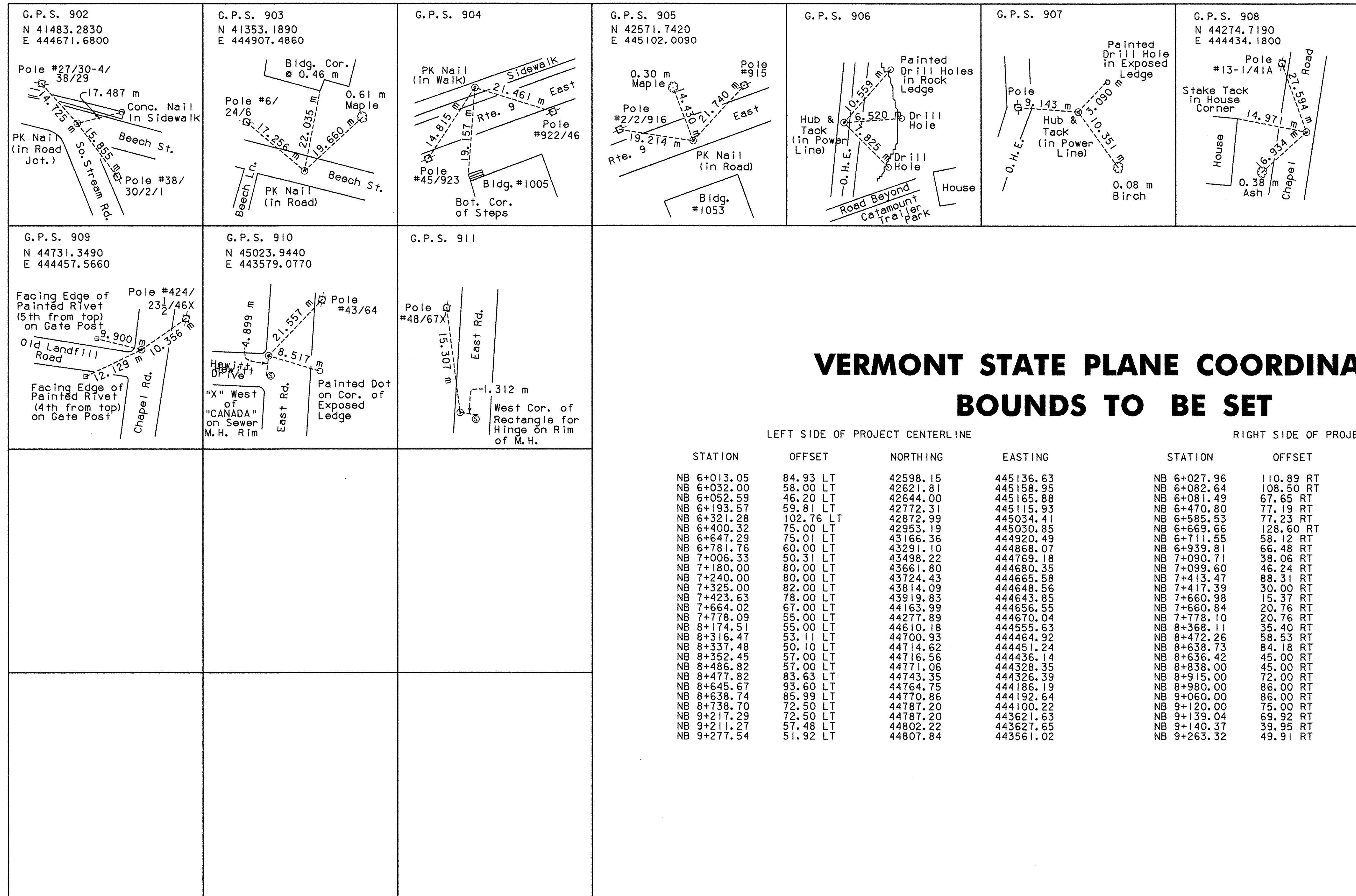

VERMONT STATE PLANE COORDINATES BOUNDS TO BE SET

| LEFT SIDE OF PROJECT CENTERLINE | | | | RIGHT SIDE OF PROJECT CENTERLINE | | | |
|---------------------------------|-----------|----------|-----------|----------------------------------|-----------|----------|-----------|
| STATION | OFFSET | NORTHING | EASTING | STATION | OFFSET | NORTHING | EASTING |
| NB 6+013.05 | 84.93 LT | 42598.15 | 445136.63 | NB 6+027.96 | 110.89 RT | 42655.21 | 445324.56 |
| NB 6+032.00 | 58.00 LT | 42621.81 | 445158.95 | NB 6+082.64 | 108.50 RT | 42710.87 | 445308.68 |
| NB 6+052.59 | 46.20 LT | 42644.00 | 445165.88 | NB 6+081.49 | 67.65 RT | 42699.57 | 445269.40 |
| NB 6+193.57 | 59.81 LT | 42772.31 | 445115.93 | NB 6+470.80 | 77.19 RT | 43081.44 | 445138.91 |
| NB 6+321.28 | 102.76 LT | 42872.99 | 445034.41 | NB 6+585.53 | 77.23 RT | 43186.62 | 445083.53 |
| NB 6+400.32 | 75.00 LT | 42953.19 | 445030.85 | NB 6+669.66 | 128.60 RT | 43285.12 | 445087.39 |
| NB 6+647.29 | 75.01 LT | 43166.36 | 444920.49 | NB 6+711.55 | 58.12 RT | 43287.35 | 445005.43 |
| NB 6+781.76 | 60.00 LT | 43291.10 | 444868.07 | NB 6+939.81 | 66.48 RT | 43489.15 | 444902.97 |
| NB 7+006.33 | 50.31 LT | 43498.22 | 444769.18 | NB 7+090.71 | 38.06 RT | 43609.68 | 444819.90 |
| NB 7+180.00 | 80.00 LT | 43661.80 | 444680.35 | NB 7+099.60 | 46.24 RT | 43620.45 | 444824.80 |
| NB 7+240.00 | 80.00 LT | 43724.43 | 444665.58 | NB 7+413.47 | 88.31 RT | 43916.71 | 444810.43 |
| NB 7+325.00 | 82.00 LT | 43814.09 | 444648.56 | NB 7+417.39 | 30.00 RT | 43917.80 | 444752.02 |
| NB 7+423.63 | 78.00 LT | 43919.83 | 444643.85 | NB 7+660.98 | 15.37 RT | 44159.87 | 444738.88 |
| NB 7+664.02 | 67.00 LT | 44163.99 | 444656.55 | NB 7+660.84 | 20.76 RT | 44159.66 | 444744.26 |
| NB 7+778.09 | 55.00 LT | 44277.89 | 444670.04 | NB 7+778.10 | 20.76 RT | 44276.91 | 444745.80 |
| NB 8+174.51 | 55.00 LT | 44610.18 | 444555.63 | NB 8+368.11 | 35.40 RT | 44802.58 | 444473.18 |
| NB 8+316.47 | 53.11 LT | 44700.93 | 444464.92 | NB 8+472.26 | 58.53 RT | 44873.83 | 444383.10 |
| NB 8+337.48 | 50.10 LT | 44714.62 | 444451.24 | NB 8+638.73 | 84.18 RT | 44941.38 | 444207.45 |
| NB 8+352.45 | 57.00 LT | 44716.56 | 444436.14 | NB 8+636.42 | 45.00 RT | 44902.13 | 444206.53 |
| NB 8+486.82 | 57.00 LT | 44771.06 | 444328.35 | NB 8+838.00 | 45.00 RT | 44904.70 | 444000.92 |
| NB 8+477.82 | 83.63 LT | 44743.35 | 444326.39 | NB 8+915.00 | 72.00 RT | 44931.70 | 443923.92 |
| NB 8+645.67 | 93.60 LT | 44764.75 | 444186.19 | NB 8+980.00 | 86.00 RT | 44945.70 | 443858.92 |
| NB 8+638.74 | 85.99 LT | 44770.86 | 444192.64 | NB 9+060.00 | 86.00 RT | 44945.70 | 443778.92 |
| NB 8+738.70 | 72.50 LT | 44787.20 | 444100.22 | NB 9+120.00 | 75.00 RT | 44934.70 | 443718.93 |
| NB 9+217.29 | 72.50 LT | 44787.20 | 443621.63 | NB 9+139.04 | 69.92 RT | 44929.63 | 443699.88 |
| NB 9+211.27 | 57.48 LT | 44802.22 | 443627.65 | NB 9+140.37 | 39.95 RT | 44899.65 | 443698.56 |
| NB 9+277.54 | 51.92 LT | 44807.84 | 443561.02 | NB 9+263.32 | 49.91 RT | 44909.62 | 443575.65 |

| | | | | |
|---|-------------------|----------------------|------------------|--------------|
| CONTROL TIE SHEET CT-3 | PROJECT NAME: | BENNINGTON BYPASS | PROJECT NUMBER: | NH FO19-1(5) |
| | DESIGN FILE NAME: | c:\dh\bennington\row | PLOT DATE: | 11-14-05 |
| | PROJECT LEADER: | JDP | DRAWN BY: | MBB |
| | | | CHECKED BY: | GAK |
| | | | SHEET: 21 OF 112 | |

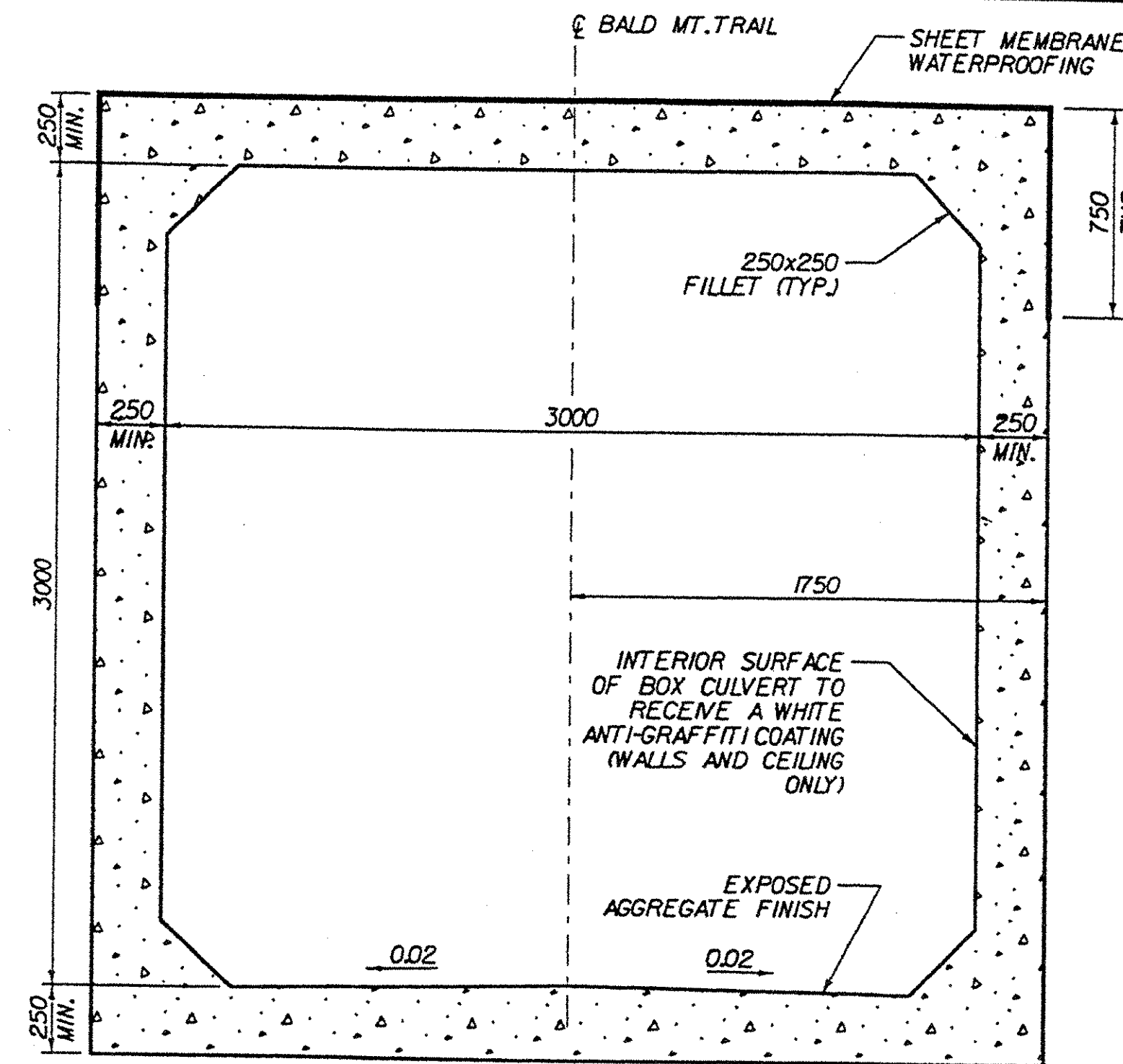

PRECAST CONCRETE BOX CULVERT TYPICAL SECTION
SCALE = 1:20

INDEX OF SHEETS

- BR300 PRELIMINARY INFORMATION SHEET
- BR301 PLAN AND PROFILE
- BR302-303 BORING INFORMATION SHEETS
- BR304-305 BORING LOGS

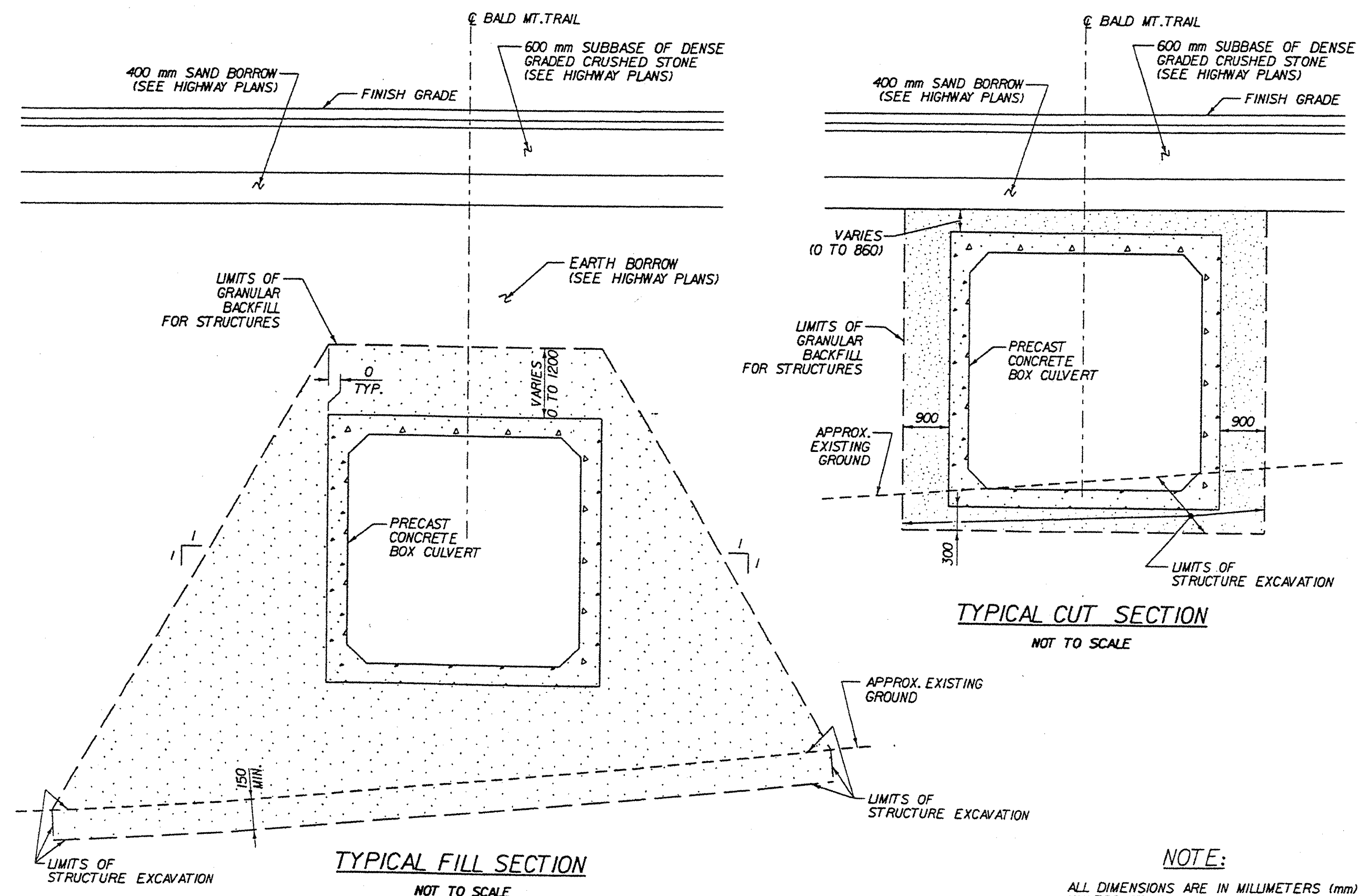

TYPICAL CUT SECTION
NOT TO SCALE

TYPICAL FILL SECTION
NOT TO SCALE

NOTE:
ALL DIMENSIONS ARE IN MILLIMETERS (mm)
UNLESS OTHERWISE NOTED.

FINAL HYDRAULICS REPORT **Metric**

HYDROLOGIC DATA

DRAINAGE AREA: _____
 CHARACTER OF TERRAIN: _____
 CHARACTER & TYPE OF STREAM: _____
 NATURE OF STREAMBED: _____
 Q2.33= _____ cms Q50= _____ cms
 Q10= _____ cms Q100= _____ cms
 Q25= _____ cms Q500= _____ cms
 DATE OF FLOOD OF RECORD: _____
 WATER SURFACE ELEV.: _____ ESTIMATED DISCHARGE: _____
 NATURAL STREAM VELOCITY @ Q50 = _____ mps
 ICE CONDITIONS: _____ DEBRIS: _____
 DOES THE STREAM REACH MAXIMUM HIGHWATER ELEVATION RAPIDLY? _____
 IS ORDINARY BASE RAPID? _____
 IS STAGE AFFECTED BY UPSTREAM OR DOWNSTREAM CONDITIONS? _____
 IF YES, DESCRIBE: _____
 WATERSHED STORAGE _____ HEADWATERS _____ UNIFORM THROUGHOUT WATERSHED _____
 IMMEDIATELY ABOVE SITE _____

PROPOSED STRUCTURE

STRUCTURE TYPE: Precast concrete box underpass
 CLEAR SPAN (NORMAL TO STREAM): N/A
 VERTICAL CLEARANCE ABOVE STREAMBED: N/A
 WATERWAY OF FULL OPENING: N/A
 WATER SURFACE ELEV. @ Q2.33= _____ VELOCITY= _____ mps
 Q10= _____ mps
 Q25= _____ mps
 Q50= _____ mps
 Q100= _____ mps
 IS THE ROADWAY OVERTOPPED BELOW THE Q100? N/A FREQUENCY: N/A
 RELIEF ELEVATION: N/A DISCHARGE OVER ROAD @ Q100: N/A
 AVERAGE LOW ELEVATION OF SUPERSTRUCTURE: _____
 VERTICAL CLEARANCE @ D 100 = _____ m
 SCOUR: Channel = N/A
 REQUIRED CHANNEL PROTECTION: N/A

EXISTING STRUCTURE

STRUCTURE TYPE: N/A YEAR BUILT: N/A
 CLEAR SPAN (NORMAL TO STREAM): N/A
 VERTICAL CLEARANCE ABOVE STREAMBED: N/A
 WATERWAY OF FULL OPENING: N/A
 DISPOSITION OF STRUCTURE: N/A
 TYPE OF MATERIAL UNDER SUBSTRUCTURE: N/A
 WATER SURFACE ELEV. @ Q2.33= _____ VELOCITY= _____ mps
 Q10= _____ mps
 Q25= _____ mps
 Q50= _____ mps
 Q100= _____ mps
 LONG TERM STREAM BED CHANGES: N/A

PERMIT INFORMATION

AVERAGE DAILY FLOW: N/A
 ORDINARY LOW WATER: _____ cms ELEV.: _____
 ORDINARY HIGH WATER: _____ cms ELEV.: _____

TEMPORARY BRIDGE REQUIREMENTS

STRUCTURE TYPE: N/A
 CLEAR SPAN (NORMAL TO STREAM): N/A
 VERTICAL CLEARANCE ABOVE STREAMBED: N/A
 WATERWAY OF FULL OPENING: N/A

DESIGN CRITERIA:

1. DESIGN LIVE LOAD AASHTO MS-22.5
2. DESIGN SPAN 3 METERS
3. ALLOWABLE LOAD FOR SPREAD FOOTINGS ON SOIL 290 kPa ON LEDGE N/A
4. ALLOWABLE LOAD FOR PILING N/A TYPE N/A ESTIMATED LENGTH N/A
5. STRUCTURAL STEEL AASHTO GRADE N/A
6. REINFORCING STEEL GRADE 420
7. CONCRETE, HIGH PERFORMANCE CLASS A $f'_c = 30$ MPA
CONCRETE, HIGH PERFORMANCE CLASS B $f'_c = 25$ MPA

TRAFFIC MAINTENANCE:

1. IS TRAFFIC TO BE MAINTAINED? NO IF YES, ON EXISTING STRUCTURE N/A OR ON TEMPORARY BRIDGE N/A
2. TEMPORARY BRIDGE REQUIREMENTS: ONE OR TWO WAY N/A TRAFFIC CONTROL SIGNALS REQUIRED N/A
 MINIMUM CLEAR SPAN (NORMAL TO STREAM): N/A VERTICAL CLEARANCE ABOVE STREAMBED: N/A
 WATERWAY AT FULL OPENING: N/A
 ARE SIDEWALKS REQUIRED? N/A IF SO, ON WHAT SIDE? N/A

LOAD RATING (TONS)

| LOADING LEVELS (LOAD FACTOR) | TRUCK | | | | |
|------------------------------|-------|----|-----|--------|----------------------------|
| | H | HS | 3S2 | 6 AXLE | 3A, STR. 4A, STR. 5A, SEMI |
| INVENTORY A = 2.17 | | | | | |
| POSTED A = 1.55 | | | | | |
| OPERATING A = 1.30 | | | | | |

**STATE OF VERMONT
AGENCY OF TRANSPORTATION**

Town Of **BENNINGTON** Bridge No. _____
 Highway No. _____ Log Sta. _____
 Surv. Sta. _____
VT ROUTE 279 OVER BALD MT. TRAIL
PRELIMINARY INFORMATION SHEET
 Designed By **S. BURBANK** Drawn By **S. BURBANK**
 Checked By **M. CHENETTE** Date **11/04** Bridge Design Supervisor **G. BOGUE** Date _____
 PROJECT **BENNINGTON** PROJECT NO. **NH F019-115**
 DH CAD Drawing Name: ... \PlotFiles\BM\BM-Planm.def: 11/12/2004
 Bridge Sheet No. BR300 Shee 22 of 112

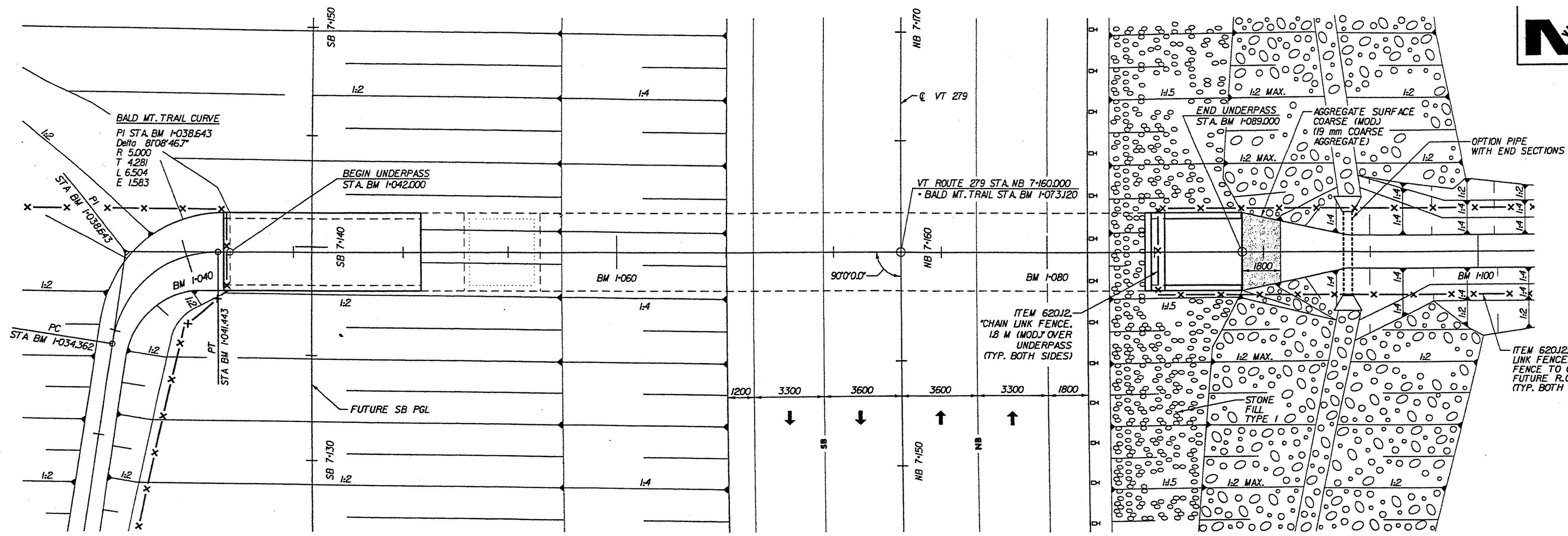
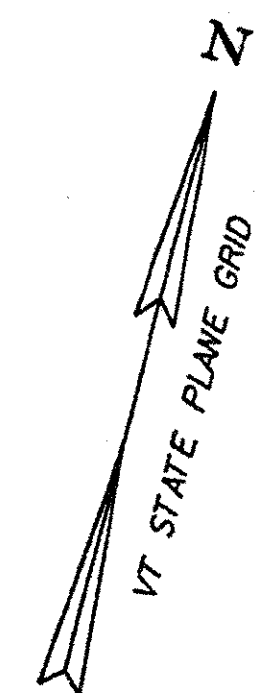

PLAN
SCALE 1:100

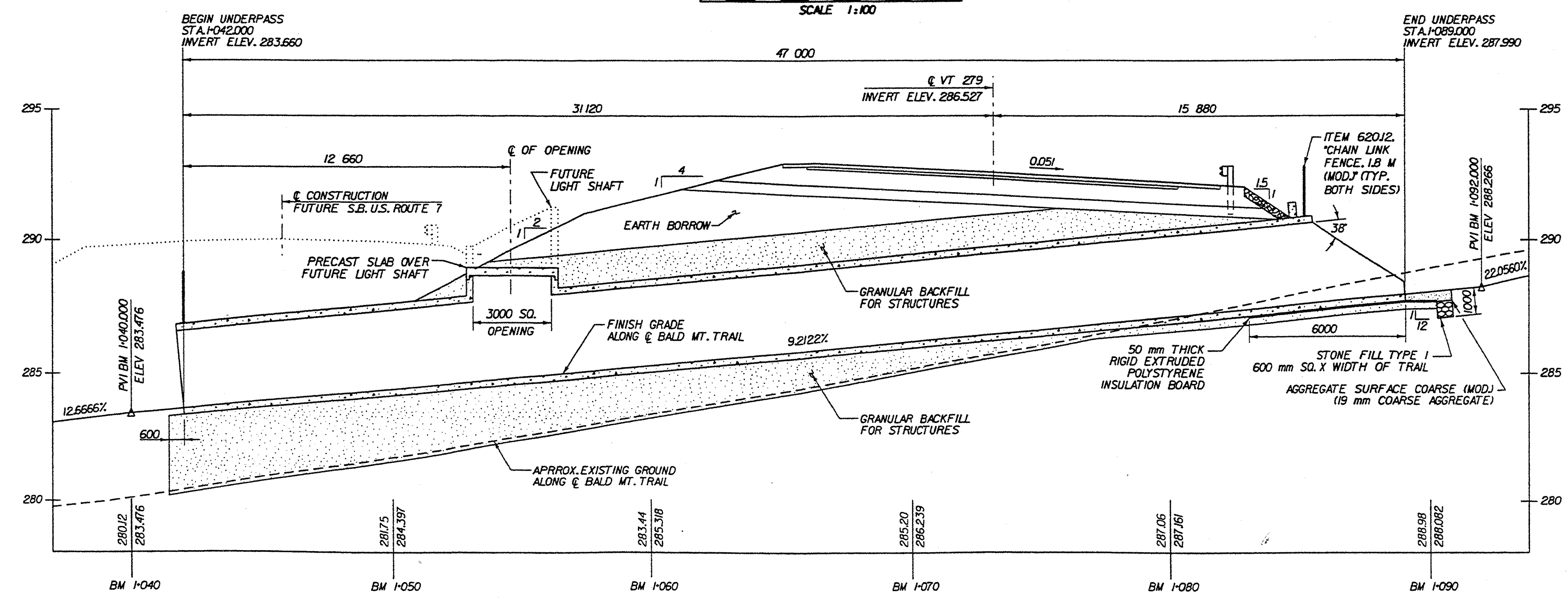

BALD MT. TRAIL PROFILE
SCALE 1:100

NOTE: ELEVATIONS SHOWN TO THE NEAREST HUNDREDTH ARE EXISTING GROUND.
ELEVATIONS SHOWN TO THE NEAREST THOUSANDTH ARE FINISH GRADE.

**STATE OF VERMONT
AGENCY OF TRANSPORTATION**

| | | | |
|-------------|------------|------------|--|
| Town Of | BENNINGTON | Bridge No. | |
| Highway No. | | Log Sta. | |
| | | Surv. Sta. | |

**VT ROUTE 279 OVER BALD MT. TRAIL
PLAN AND PROFILE**

| | | | |
|-------------|------------|--------------------------|------|
| Designed By | S. BURBANK | Drawn By | |
| Checked By | Date | Bridge Design Supervisor | |
| M. CHENETTE | 11/04 | G. BOGUE | Date |

| | | | |
|---------|------------|-------------|--------------|
| PROJECT | BENNINGTON | PROJECT NO. | NH F019-1(5) |
|---------|------------|-------------|--------------|



K:\S\80020 (Benn)\Structures\Plan\Files\BM\BM-plan.p10

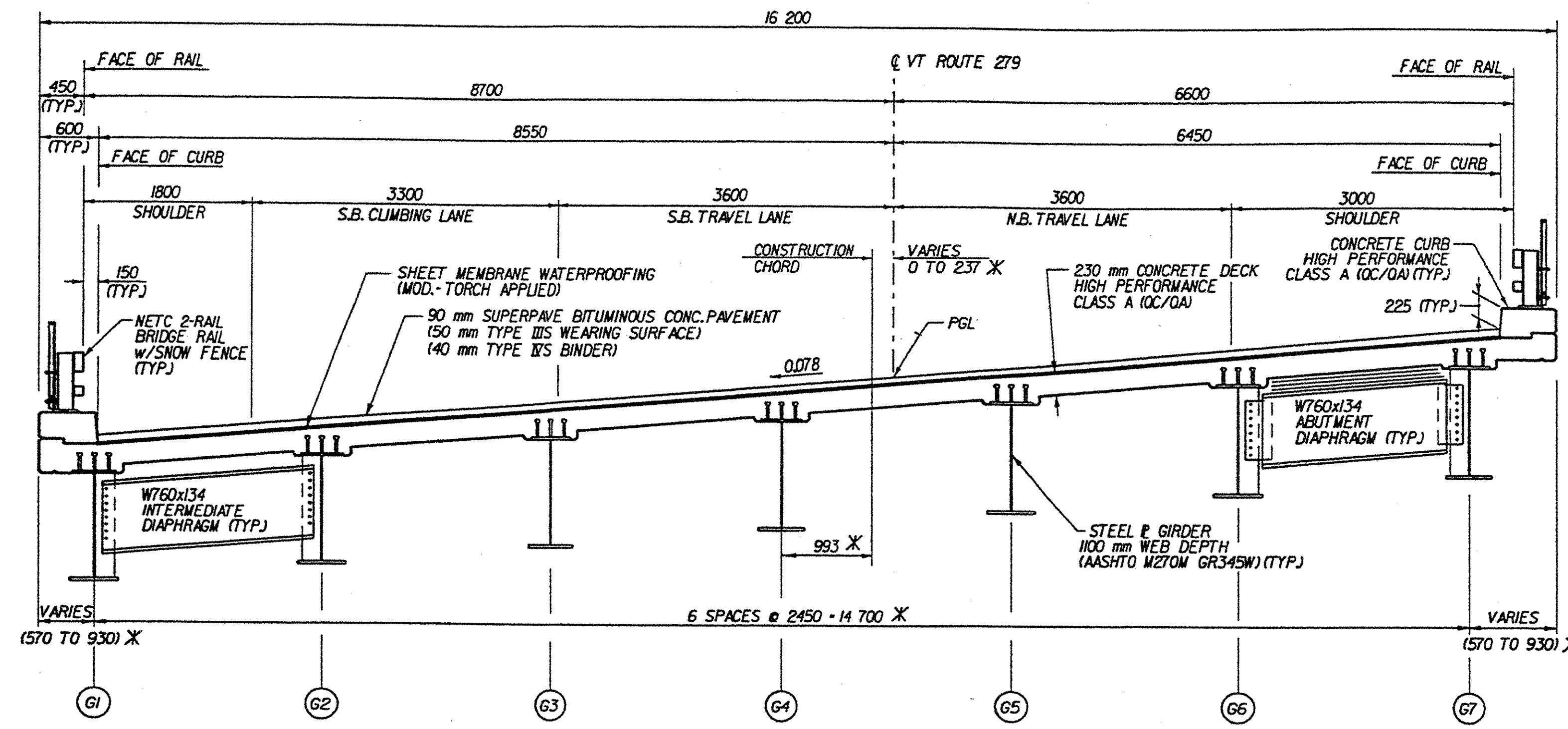

BRIDGE TYPICAL SECTION
SCALE 1:40

NOTE: ALL DIMENSIONS ARE RADIAL AND CONCENTRIC WITH ϕ OF CONSTRUCTION UNLESS NOTED OTHERWISE.

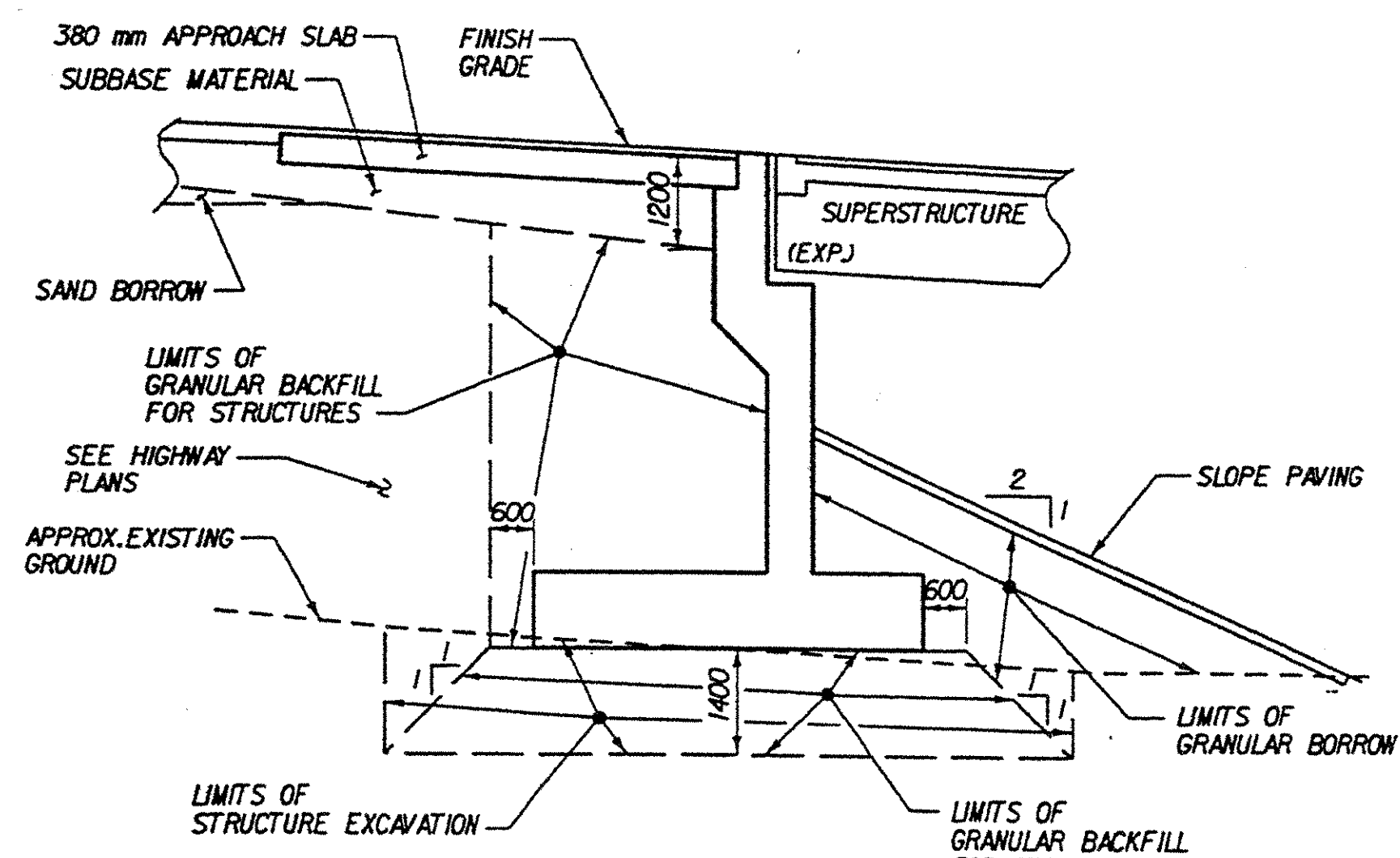

TYPICAL ABUTMENT 1 SECTION
NOT TO SCALE

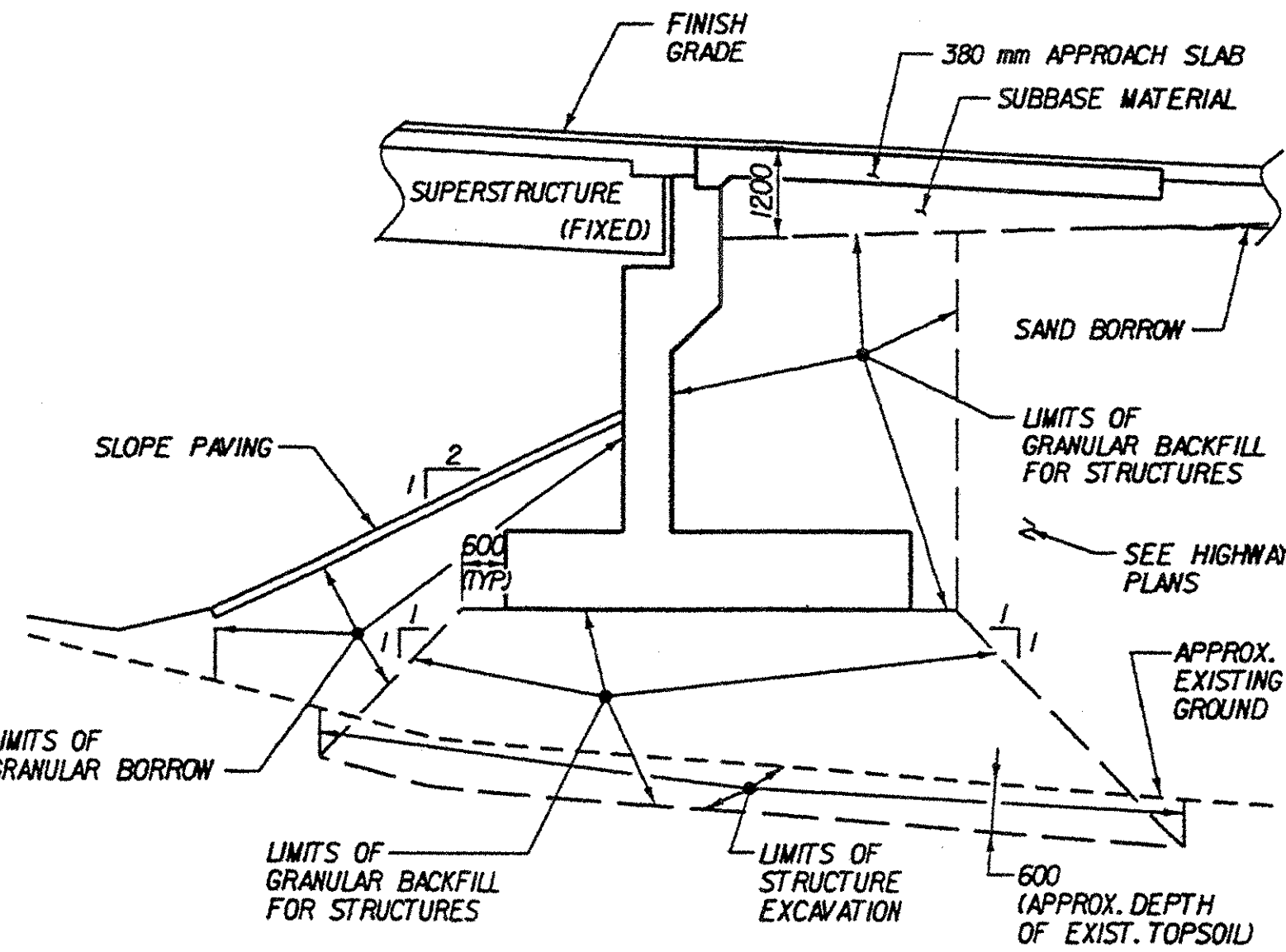

TYPICAL ABUTMENT 2 SECTION
NOT TO SCALE

INDEX OF SHEETS

- BR400 PRELIMINARY INFORMATION SHEET
- BR401 GENERAL PLAN AND ELEVATION
- BR402-403 BORING INFORMATION SHEETS
- BR404-409 BORING LOGS

NOTE:

ALL DIMENSIONS ARE IN MILLIMETERS (mm) UNLESS OTHERWISE NOTED.

FINAL HYDRAULICS REPORT **Metric**

HYDROLOGIC DATA

DRAINAGE AREA: _____
 CHARACTER OF TERRAIN: _____
 CHARACTER & TYPE OF STREAM: _____
 NATURE OF STREAMBED: _____

02.33= _____ cms 050= _____ cms
 010= _____ cms 0100= _____ cms
 025= _____ cms 0500= _____ cms

DATE OF FLOOD OF RECORD: _____
 WATER SURFACE ELEV. @ 050: _____ ESTIMATED DISCHARGE: _____
 NATURAL STREAM VELOCITY @ 050: _____ mps
 ICE CONDITIONS: _____ DEBRIS: _____
 DOES THE STREAM REACH MAXIMUM HIGHWATER ELEVATION RAPIDLY? _____
 IS ORDINARY RISE RAPID? _____
 IS STAGE AFFECTED BY UPSTREAM OR DOWNSTREAM CONDITIONS? _____
 IF YES, DESCRIBE: _____
 WATERSHED STORAGE: _____ HEADWATERS: _____ UNIFORM THROUGHOUT WATERSHED: _____ IMMEDIATELY ABOVE SITE: _____

PROPOSED STRUCTURE

STRUCTURE TYPE: Single span plate girder bridge

CLEAR SPAN (NORMAL TO STREAM): N/A
 VERTICAL CLEARANCE ABOVE STREAMBED: N/A
 WATERWAY OF FULL OPENING: N/A

WATER SURFACE ELEV. @ 02.33= _____ VELOCITY: _____ mps
 010= _____ mps
 025= _____ mps
 050= _____ mps
 0100= _____ mps

IS THE ROADWAY OVERTOPPED BELOW THE 0100? N/A FREQUENCY: N/A
 RELIEF ELEVATION: N/A DISCHARGE OVER ROAD @ 0100: N/A

AVERAGE LOW ELEVATION OF SUPERSTRUCTURE: _____
 VERTICAL CLEARANCE @ 0 100 = _____ m

SCOUR: Channel = N/A
 REQUIRED CHANNEL PROTECTION: N/A

EXISTING STRUCTURE

STRUCTURE TYPE: N/A YEAR BUILT: N/A
 CLEAR SPAN (NORMAL TO STREAM): N/A
 VERTICAL CLEARANCE ABOVE STREAMBED: N/A
 WATERWAY OF FULL OPENING: N/A
 DISPOSITION OF STRUCTURE: N/A

TYPE OF MATERIAL UNDER SUBSTRUCTURE: N/A

WATER SURFACE ELEV. @ 02.33= _____ VELOCITY: _____ mps
 010= _____ mps
 025= _____ mps
 050= _____ mps
 0100= _____ mps

LONG TERM STREAM BED CHANGES: N/A

IS THE ROADWAY OVERTOPPED BELOW THE 0100? N/A FREQUENCY: N/A
 RELIEF ELEVATION: N/A DISCHARGE OVER ROAD @ 0100: N/A

UPSTREAM STRUCTURE: TOWN: N/A DISTANCE: _____
 HIGHWAY NO.: _____ STRUCTURE NO.: _____
 STRUCTURE TYPE: _____
 CLEAR SPAN: _____ CLEAR HEIGHT: _____
 YEAR BUILT: _____ FULL WATERWAY: _____

DOWNSTREAM STRUCTURE: TOWN: N/A DISTANCE: _____
 HIGHWAY NO.: _____ STRUCTURE NO.: _____
 STRUCTURE TYPE: _____
 CLEAR SPAN: _____ CLEAR HEIGHT: _____
 YEAR BUILT: _____ FULL WATERWAY: _____

(COMPLETE INFORMATION WILL BE PROVIDED ON FINAL PLANS)

PERMIT INFORMATION

AVERAGE DAILY FLOW: N/A
 ORDINARY LOW WATER: _____ cms ELEV.: _____
 ORDINARY HIGH WATER: _____ cms ELEV.: _____

TEMPORARY BRIDGE REQUIREMENTS

STRUCTURE TYPE: N/A
 CLEAR SPAN (NORMAL TO STREAM): N/A
 VERTICAL CLEARANCE ABOVE STREAMBED: N/A
 WATERWAY OF FULL OPENING: N/A

DESIGN CRITERIA:

- DESIGN LIVE LOAD AASHTO MS-22.5
- DESIGN SPAN 33 m
- ALLOWABLE LOAD FOR SPREAD FOOTINGS ON SOIL 290 kPa
- ALLOWABLE LOAD FOR PILING N/A TYPE N/A ESTIMATED LENGTH ON LEDGE N/A
- STRUCTURAL STEEL AASHTO GRADE M20M GR345W
- REINFORCING STEEL GRADE 420
- CONCRETE, HIGH PERFORMANCE CLASS A (QC/OA) $f_c = 30$ MPA
 CONCRETE, HIGH PERFORMANCE CLASS B $f_c = 25$ MPA

TRAFFIC MAINTENANCE:

- IS TRAFFIC TO BE MAINTAINED? YES IF YES, ON EXISTING STRUCTURE N/A OR ON TEMPORARY BRIDGE N/A
- TEMPORARY BRIDGE REQUIREMENTS: ONE OR TWO WAY N/A TRAFFIC CONTROL SIGNALS REQUIRED N/A

MINIMUM CLEAR SPAN (NORMAL TO STREAM): N/A VERTICAL CLEARANCE ABOVE STREAMBED: N/A
 WATERWAY AT FULL OPENING: N/A
 ARE SIDEWALKS REQUIRED? N/A IF SO, ON WHAT SIDE? N/A

| LOADING LEVELS (LOAD FACTOR) | LOAD RATING (TONS) | | | | | | |
|------------------------------|--------------------|----|-----|--------|----------|----------|---------|
| | H | HS | 3S2 | 6 AXLE | 3A. STR. | 4A. STR. | 5A. SEW |
| INVENTORY A = 2.17 | | | | | | | |
| POSTED A = 1.55 | | | | | | | |
| OPERATING A = 1.30 | | | | | | | |

STATE OF VERMONT AGENCY OF TRANSPORTATION

Town Of **BENNINGTON** Bridge No. _____
 Highway No. _____ Log Sta. _____
 Surv. Sta. _____

VT ROUTE 279 OVER CHAPEL ROAD

PRELIMINARY INFORMATION SHEET

Designed By **S. BURBANK** Drawn By **A. THIBAUT**
 Checked By _____ Date _____ Bridge Design Supervisor
M. CHENETTE 11/04 **G. BOGUE** Date _____

PROJECT **BENNINGTON** PROJECT NO. **NH F019-1K5**
 DH CAD Drawing Name: ...PlotFiles\CH\CH-PR019-1K5.dwg Date: 11/17/2004
 Bridge Sheet No. **BR400** Sheet **24** of **112**



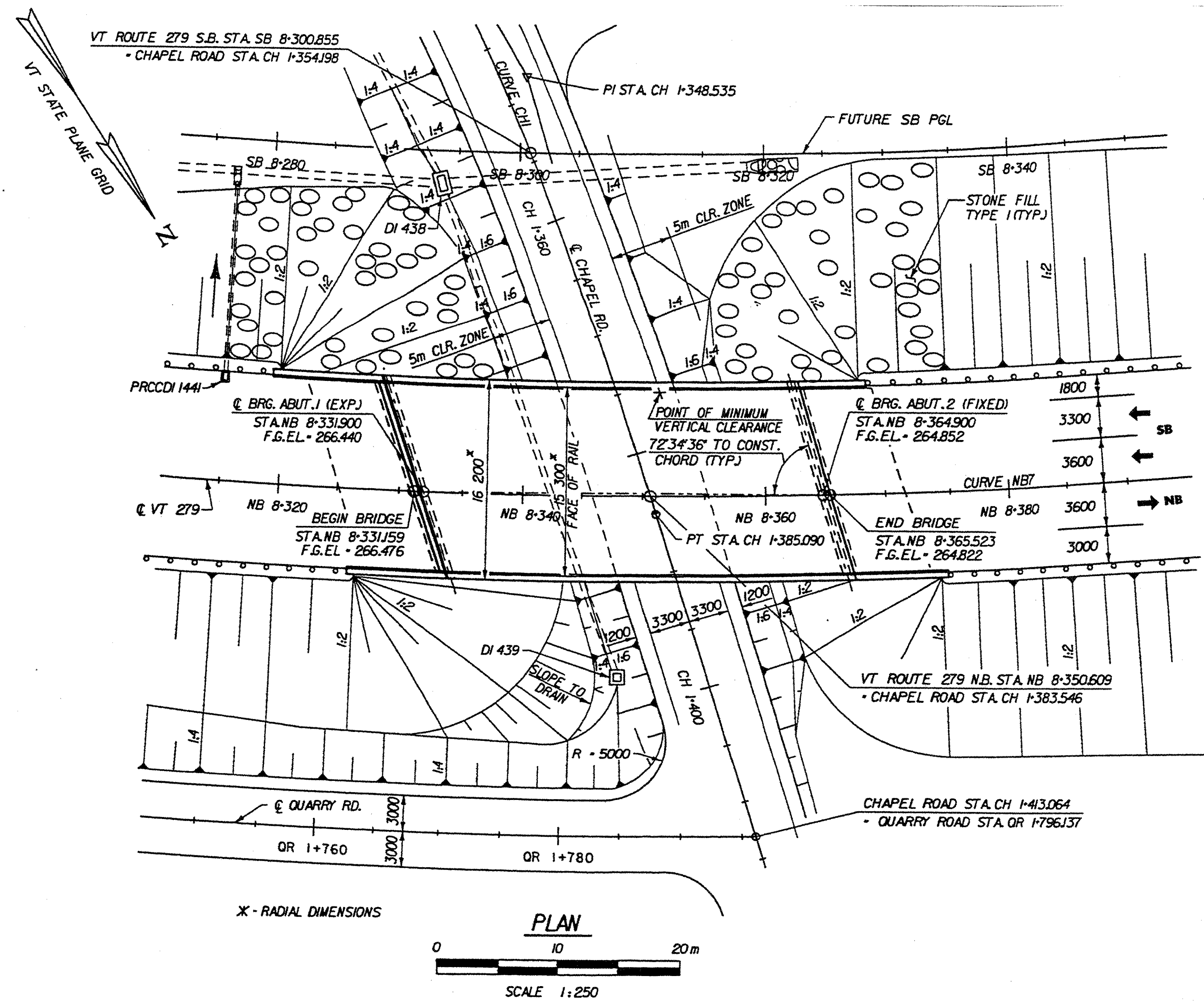

CURVE CHI
 PI STA. CH 1+348.535
 DELTA = 13°20'29.3\"/>
 R = 315.411 m
 T = 36.889 m
 L = 73.444 m
 E = 2.150 m
 BANK = 0.044

CURVE NB7
 PI STA. NB 8+360.574
 Delta = 90°45'02.2\"/>
 R = 575.000 m
 T = 582.583 m
 L = 910.741 m
 E = 243.552 m
 BANK = 0.078

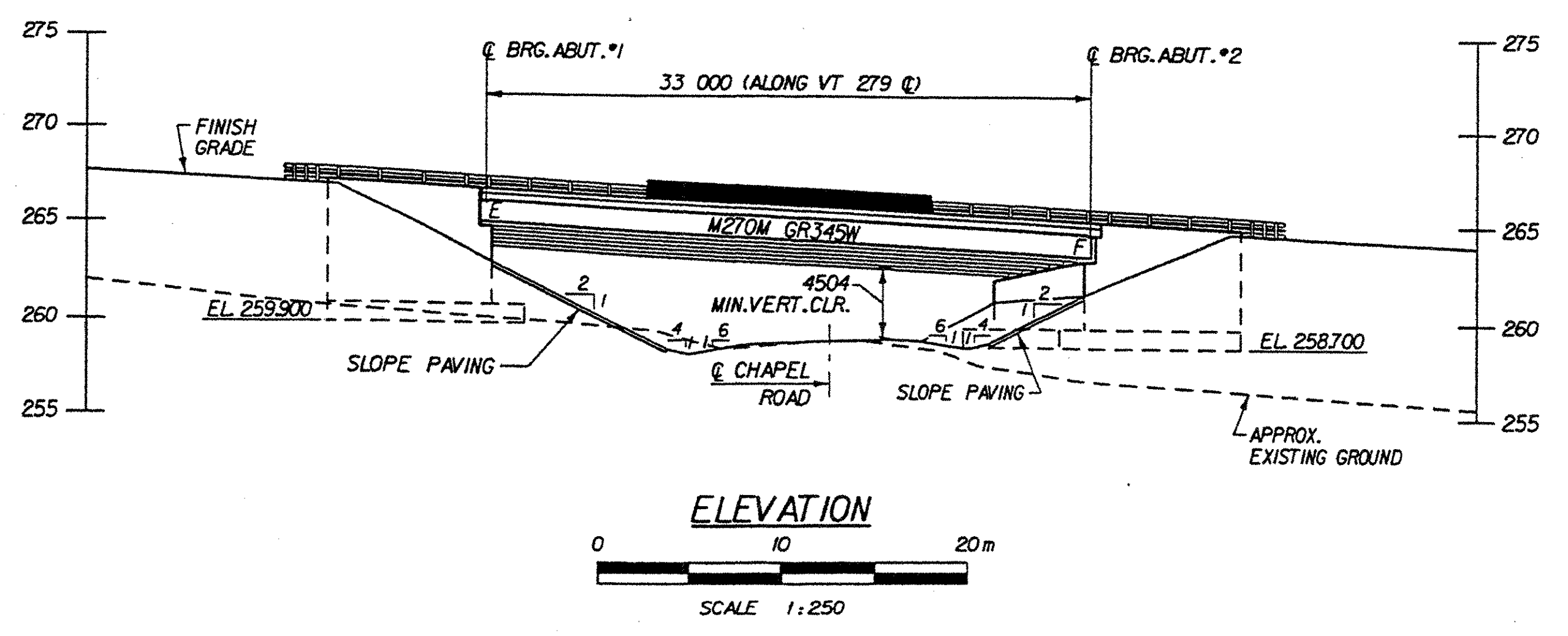
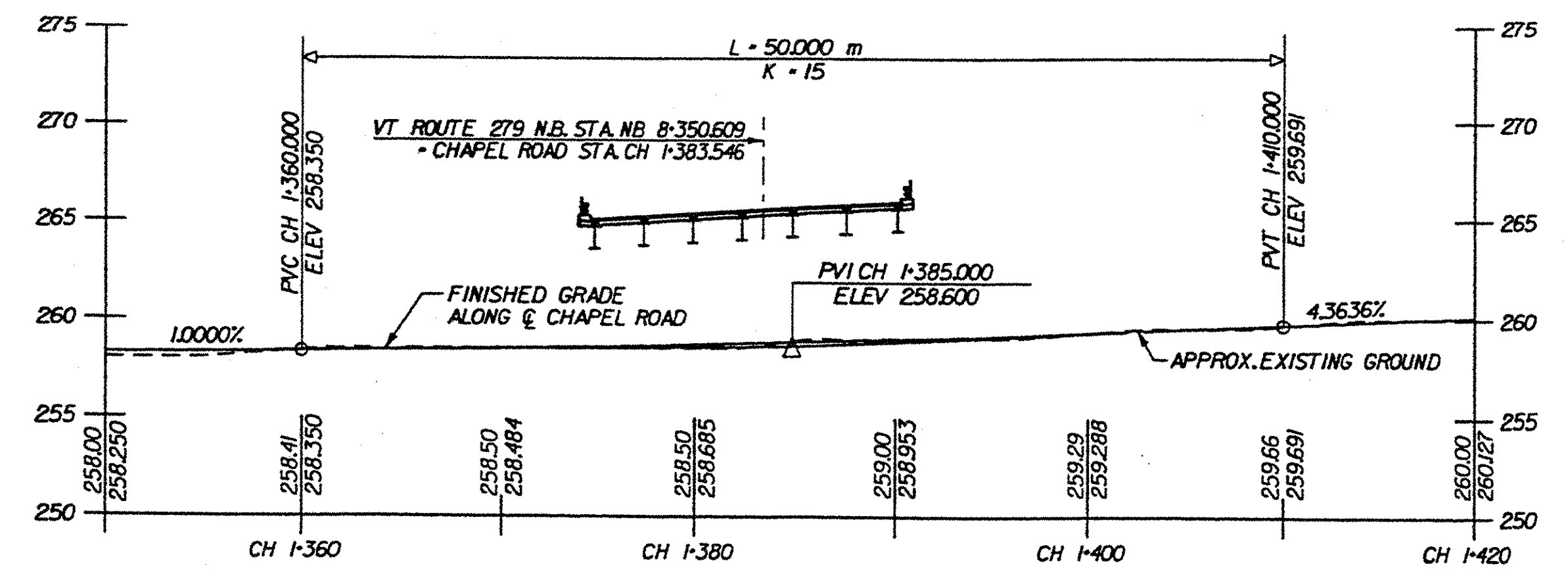

**STATE OF VERMONT
 AGENCY OF TRANSPORTATION**

| | | | |
|---|-------------|--------------------------|--------------|
| Town Of | BENNINGTON | Bridge No. | |
| Highway No. | | Log Sta. | |
| | | Surv. Sta. | |
| VT ROUTE 279 OVER CHAPEL ROAD | | | |
| PLAN AND ELEVATION | | | |
| Designed By | T. KNIGHT | Drawn By | T. KNIGHT |
| Checked By | M. CHENETTE | Date | 11/04 |
| | | Bridge Design Supervisor | G. BOGUE |
| | | Date | |
| PROJECT | BENNINGTON | PROJECT NO. | NH F019-(15) |
| DH CAD Drawing Name: ... \PlotFiles\CH\CH-PR04 Date: 11/17/2004 | | | |
| Bridge Sheet No. | BR401 | Sheet | 25 of 112 |

REVISED

X:\630020\Benn\Structures\PlotFiles\CH-Plan.dwg

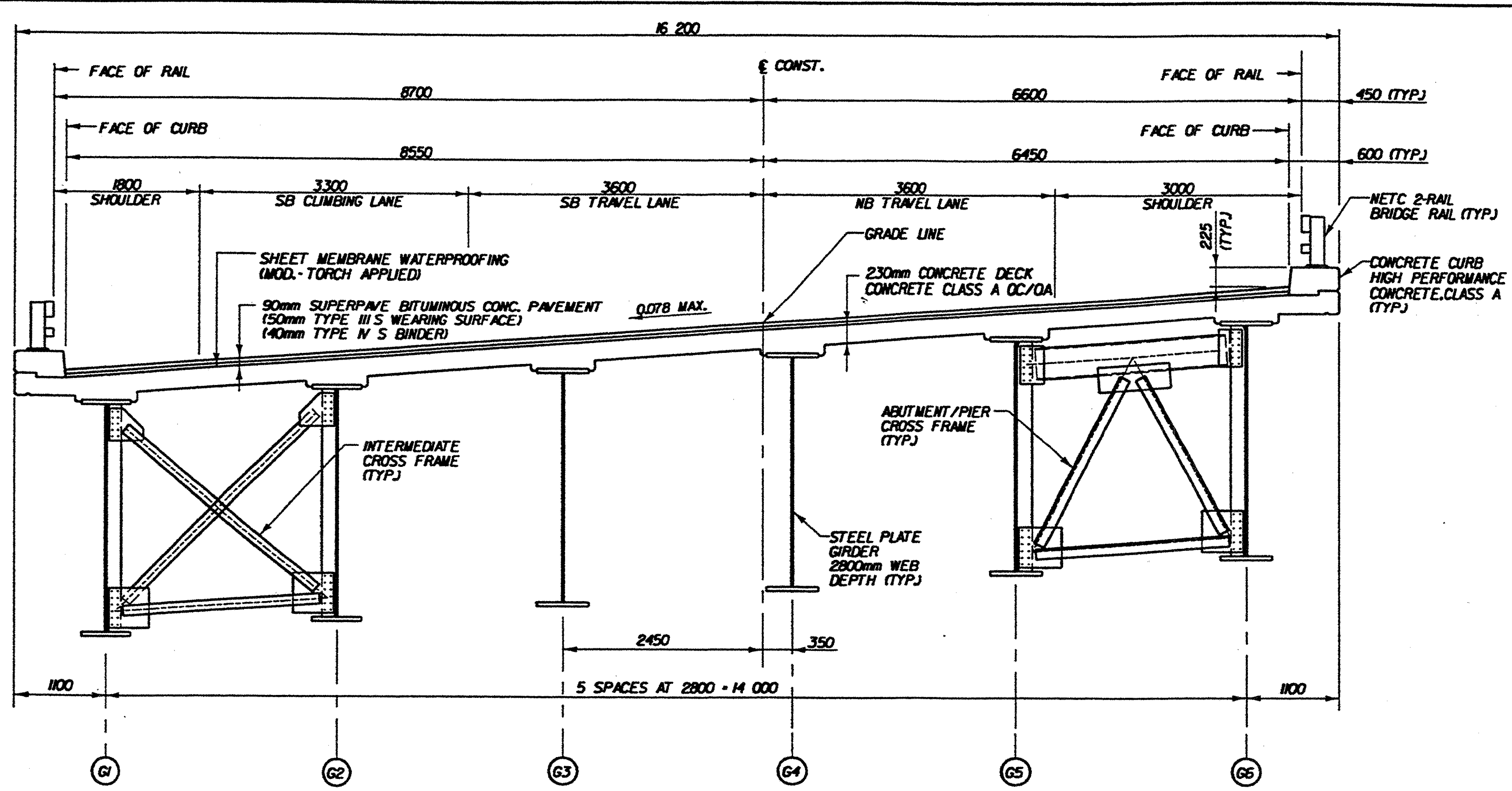

BRIDGE TYPICAL SECTION
SCALE 1:40

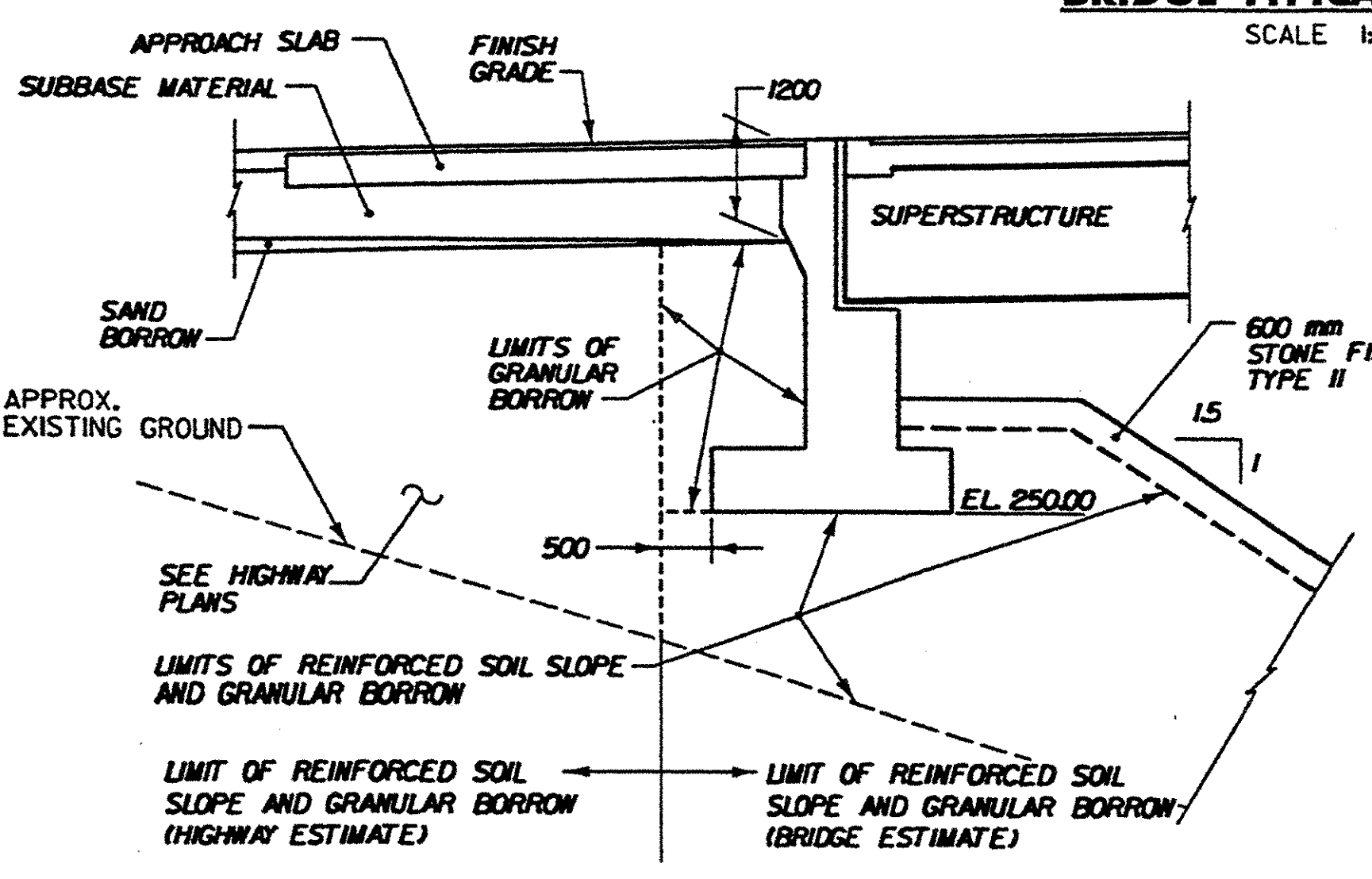

TYPICAL ABUTMENT 1 SECTION
NOT TO SCALE

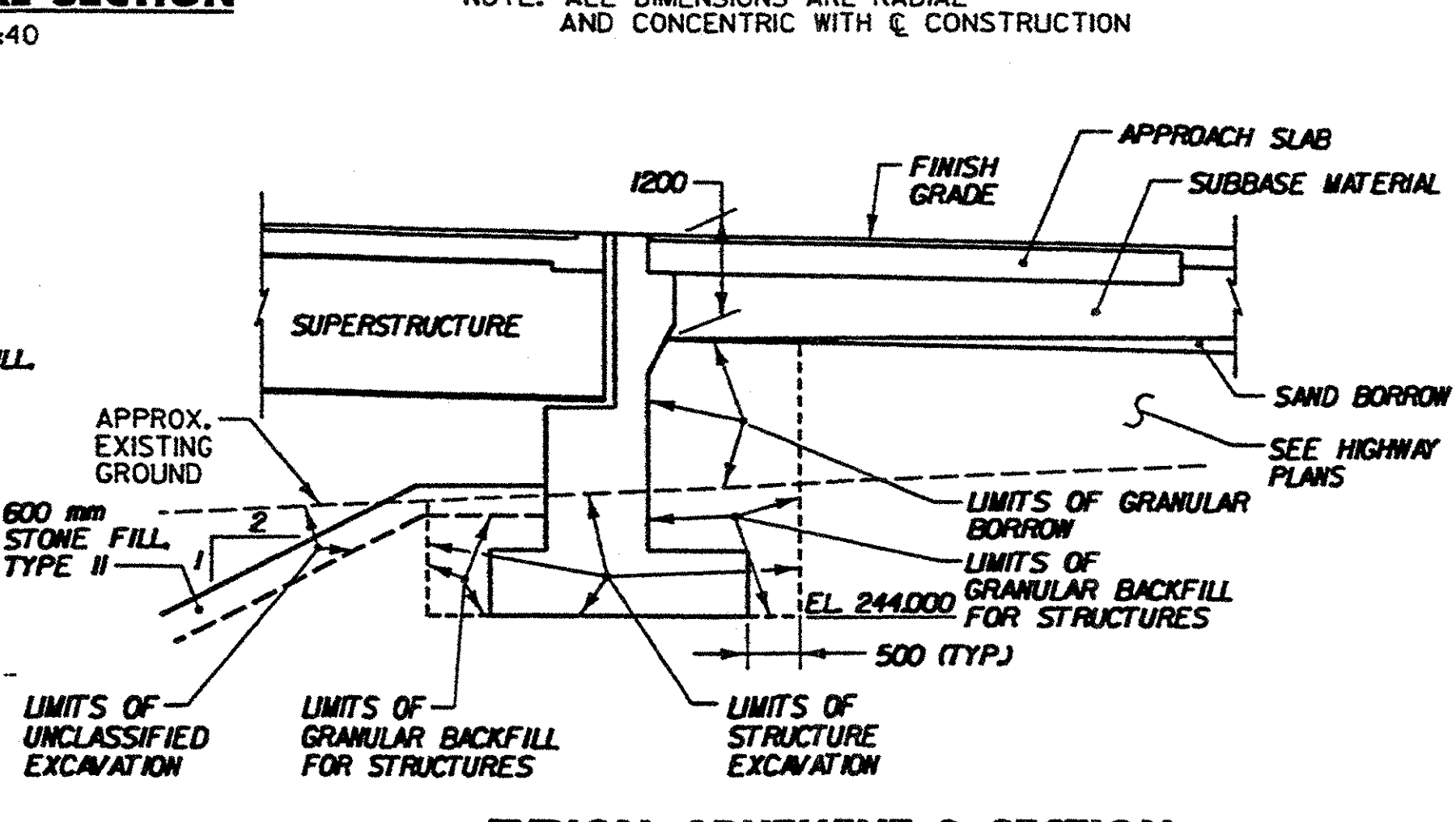

TYPICAL ABUTMENT 2 SECTION
NOT TO SCALE

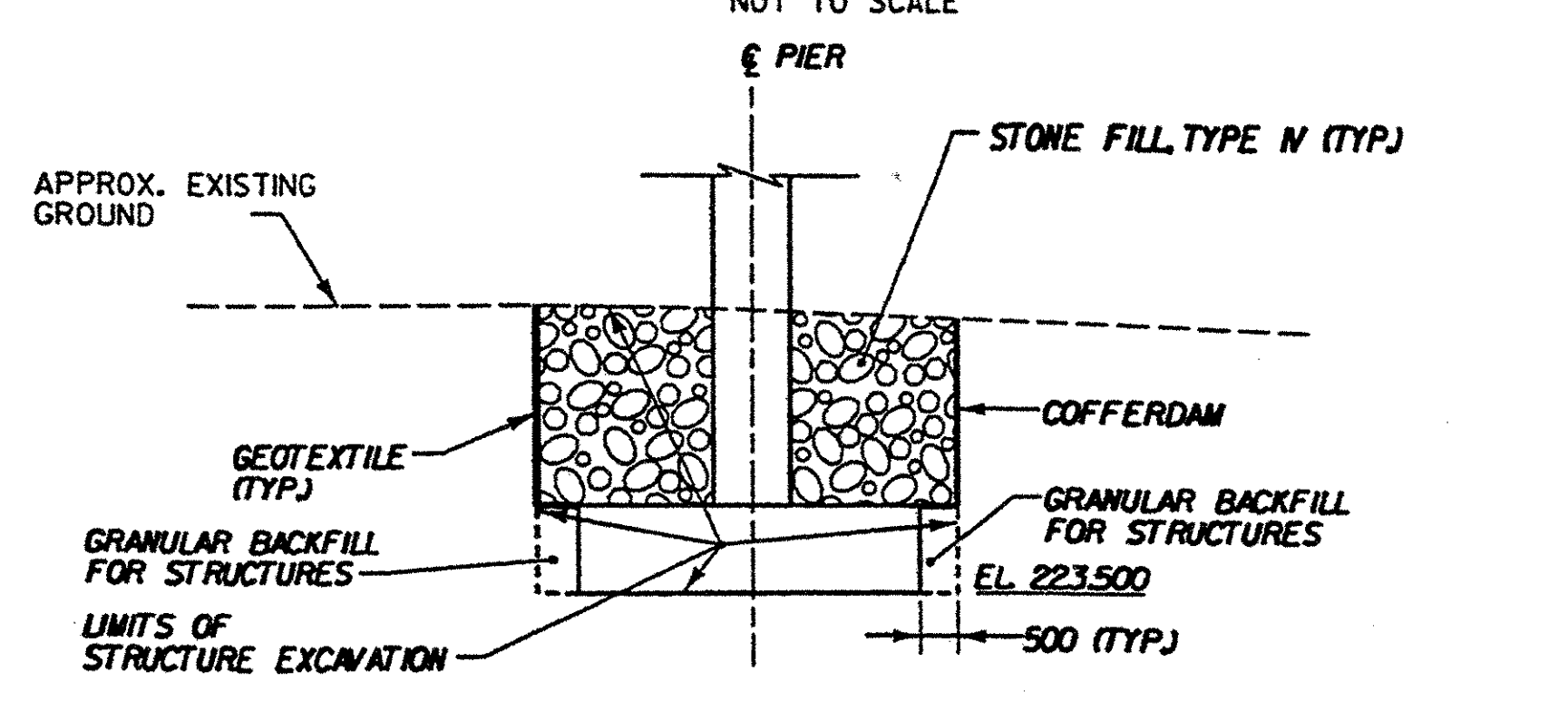

TYPICAL PIER SECTION
NOT TO SCALE

INDEX OF SHEETS

- BR500 PRELIMINARY INFORMATION SHEET
- BR501 GENERAL PLAN AND ELEVATION
- BR502-504 CONSTRUCTION IMPACTS PLANS, NOTES & DETAILS
- BR505-506 BORING INFORMATION SHEETS
- BR507-510 BORING LOGS
- BR511 CHANNEL AND PIER DETAILS
- BR512-519 CHANNEL CROSS SECTIONS

NOTE:
ALL DIMENSIONS ARE IN MILLIMETERS (mm)
UNLESS OTHERWISE NOTED.

HYDROLOGIC DATA

DRAINAGE AREA: 29.1 sq. km
 CHARACTER OF TERRAIN: Mountainous
 CHARACTER & TYPE OF STREAM: Sinuous, perennial in alluvium
 NATURE OF STREAMBED: Cobble layer interlaced with sand & gravel

| | |
|---------------|---------------|
| 02.33= 27 cms | 050= 63 cms |
| 010= 46 cms | 0100= 71 cms |
| 025= 56 cms | 0500= 121 cms |

DATE OF FLOOD OF RECORD: Unknown
 WATER SURFACE ELEV.: Unknown ESTIMATED DISCHARGE: Unknown
 NATURAL STREAM VELOCITY @ 050 = 2.49 mps
 ICE CONDITIONS: Moderate DEBRIS: Slight
 DOES THE STREAM REACH MAXIMUM HIGHWATER ELEVATION RAPIDLY? Yes
 IS ORDINARY RISE RAPID? Yes
 IS STAGE AFFECTED BY UPSTREAM OR DOWNSTREAM CONDITIONS? No
 IF YES, DESCRIBE: _____
 WATERSHED STORAGE: _____ HEADWATERS: UNIFORM THROUGHOUT WATERSHED
 IMMEDIATELY ABOVE SITE _____

EXISTING STRUCTURE

STRUCTURE TYPE: N/A YEAR BUILT: N/A
 CLEAR SPAN (NORMAL TO STREAM): N/A
 VERTICAL CLEARANCE ABOVE STREAMBED: N/A
 WATERWAY OF FULL OPENING: N/A
 DISPOSITION OF STRUCTURE: N/A
 TYPE OF MATERIAL UNDER SUBSTRUCTURE: N/A

| | |
|------------------------------------|--------------------|
| WATER SURFACE ELEV. @ 02.33= 230.4 | VELOCITY= 1.94 mps |
| 010= 230.8 | 2.31 mps |
| 025= 231.0 | 2.44 mps |
| 050= 231.1 | 2.49 mps |
| 0100= 231.2 | 2.60 mps |

LONG TERM STREAM BED CHANGES: N/A
 IS THE ROADWAY OVERTOPPED BELOW THE 0100? N/A FREQUENCY: N/A
 RELIEF ELEVATION: N/A DISCHARGE OVER ROAD @ 0100: N/A

UPSTREAM STRUCTURE: TOWN: N/A DISTANCE: N/A
 HIGHWAY NO.: N/A STRUCTURE NO.: N/A
 STRUCTURE TYPE: N/A ESTIMATED LENGTH: N/A
 CLEAR SPAN: N/A CLEAR HEIGHT: N/A
 YEAR BUILT: N/A FULL WATERWAY: N/A

DOWNSTREAM STRUCTURE: TOWN: BENNINGTON DISTANCE: 0.9 km
 HIGHWAY NO.: N. BRANCH ST. STRUCTURE NO.: N/A
 STRUCTURE TYPE: N/A ESTIMATED LENGTH: N/A
 CLEAR SPAN: N/A CLEAR HEIGHT: N/A
 YEAR BUILT: N/A FULL WATERWAY: N/A

(COMPLETE INFORMATION WILL BE PROVIDED ON FINAL PLANS)

DESIGN CRITERIA:

- DESIGN LIVE LOAD AASHTO: MS-22.5
- DESIGN SPAN: 71.5 m - 71.5 m
- ALLOWABLE LOAD FOR SPREAD FOOTINGS ON SOIL: 290 kPa (Abut. 1), 480 kPa (Pier) & 380 kPa (Abut. 2) ON LEDGE: N/A
- ALLOWABLE LOAD FOR PILING: N/A TYPE: N/A ESTIMATED LENGTH: N/A
- STRUCTURAL STEEL AASHTO GRADE: M270M GR345M HYBRID WITH ASTM A709M GR HP5485M WEATHERING STEEL
- REINFORCING STEEL GRADE: 420
- CONCRETE CLASS A: $f_c = 30$ MPa OC/OA
 CONCRETE CLASS B: $f_c = 30$ MPa HIGH PERFORMANCE CONCRETE
 CONCRETE CLASS C: $f_c = 25$ MPa

TRAFFIC MAINTENANCE:

- IS TRAFFIC TO BE MAINTAINED? NO IF YES, ON EXISTING STRUCTURE: N/A OR ON TEMPORARY BRIDGE: N/A
- TEMPORARY BRIDGE REQUIREMENTS: ONE OR TWO WAY: N/A TRAFFIC CONTROL SIGNALS REQUIRED: N/A

MINIMUM CLEAR SPAN (NORMAL TO STREAM): N/A VERTICAL CLEARANCE ABOVE STREAMBED: N/A
 WATERWAY AT FULL OPENING: N/A
 ARE SIDEWALKS REQUIRED? N/A IF SO, ON WHAT SIDE? N/A

| LOADING LEVELS (LOAD FACTOR) | LOAD RATING (TONS) | | | | |
|------------------------------|--------------------|----|-----|--------|----------------------------|
| | H | HS | SS2 | 6 AXLE | 3A. STR. 4A. STR. 5A. SEMI |
| INVENTORY A = 2.17 | | | | | |
| POSTED A = 1.55 | | | | | |
| OPERATING A = 1.30 | | | | | |

RF = $\frac{M}{L} = \frac{1.3}{M.L.}$
 $A \times M.L. = 1$

SEMI-FINAL PLAN SUBMISSION
 DATE 12-08-04

TVGA CONSULTANTS

PROPOSED STRUCTURE

STRUCTURE TYPE: Two open curved plate girder bridge
 CLEAR SPAN (NORMAL TO STREAM): 143 m
 VERTICAL CLEARANCE ABOVE STREAMBED: 20 m
 WATERWAY OF FULL OPENING: 2100 sq. m

| | |
|------------------------------------|--------------------|
| WATER SURFACE ELEV. @ 02.33= 230.5 | VELOCITY= 1.81 mps |
| 010= 230.9 | 2.18 mps |
| 025= 231.0 | 2.35 mps |
| 050= 231.1 | 2.48 mps |
| 0100= 231.2 | 2.61 mps |

IS THE ROADWAY OVERTOPPED BELOW THE 0100? No FREQUENCY: N.A.
 RELIEF ELEVATION: N.A. DISCHARGE OVER ROAD @ 0100: None

AVERAGE LOW ELEVATION OF SUPERSTRUCTURE: 251.8
 VERTICAL CLEARANCE @ 0 100 = 19 m

SCOUR: Channel = 0.8 m, Pier = 4.5 m
 REQUIRED CHANNEL PROTECTION: Stone Fill, Type IV

PERMIT INFORMATION

| | |
|-----------------------------|-------------------------------|
| AVERAGE DAILY FLOW: 4.3 cms | ELEV.: 229.3 |
| ORDINARY LOW WATER: 2.3 cms | ORDINARY HIGH WATER: 12.7 cms |
| | ELEV.: 230.0 |

TEMPORARY BRIDGE REQUIREMENTS

STRUCTURE TYPE: N/A
 CLEAR SPAN (NORMAL TO STREAM): N/A
 VERTICAL CLEARANCE ABOVE STREAMBED: N/A
 WATERWAY OF FULL OPENING: N/A

STATE OF VERMONT AGENCY OF TRANSPORTATION

Town Of: BENNINGTON Bridge No. _____
 Highway No. _____ Log Sta. _____
 Surv. Sta. _____

VT ROUTE 279 OVER FURNACE BROOK

PRELIMINARY INFORMATION SHEET

Designed By: M. HANN Drawn By: R.A. BOTZENHART
 Checked By: _____ Date: _____
 Bridge Design Supervisor: K.M. WOJTKOWSKI Date: _____

PROJECT: BENNINGTON PROJECT NO.: NH F019-1K5
 TVGA CAD Drawing No. pl.sheet Date: _____
 Bridge Sheet No. BR500 Sheet 26 of 112

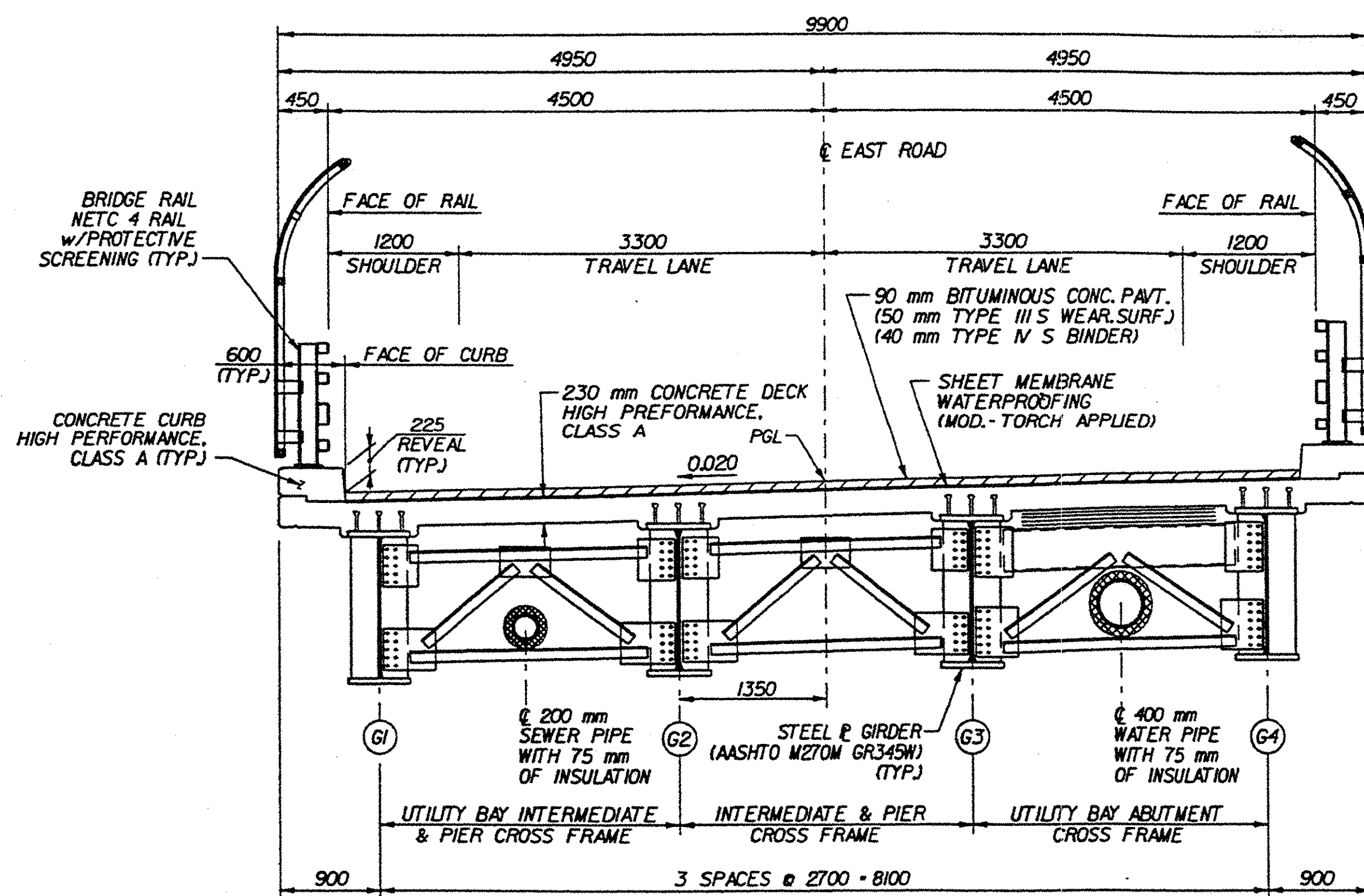

NOTE: ALL DIMENSIONS ARE RADIAL AND CONCENTRIC WITH @ EAST ROAD.

BRIDGE TYPICAL SECTION
SCALE 1:40

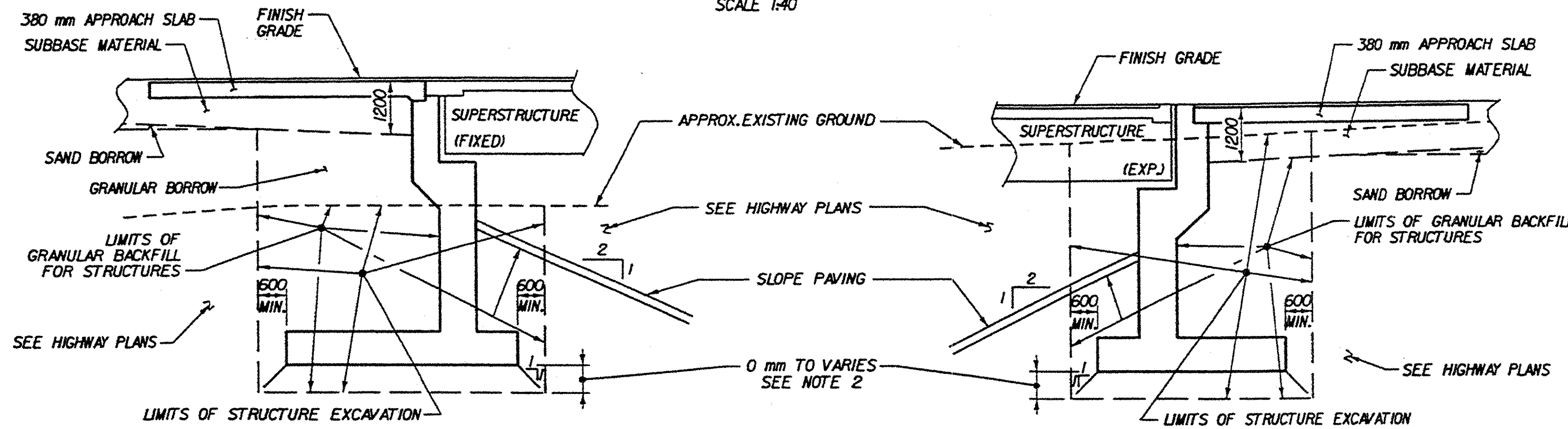

TYPICAL ABUTMENT 1 SECTION
NOT TO SCALE

TYPICAL ABUTMENT 2 SECTION
NOT TO SCALE

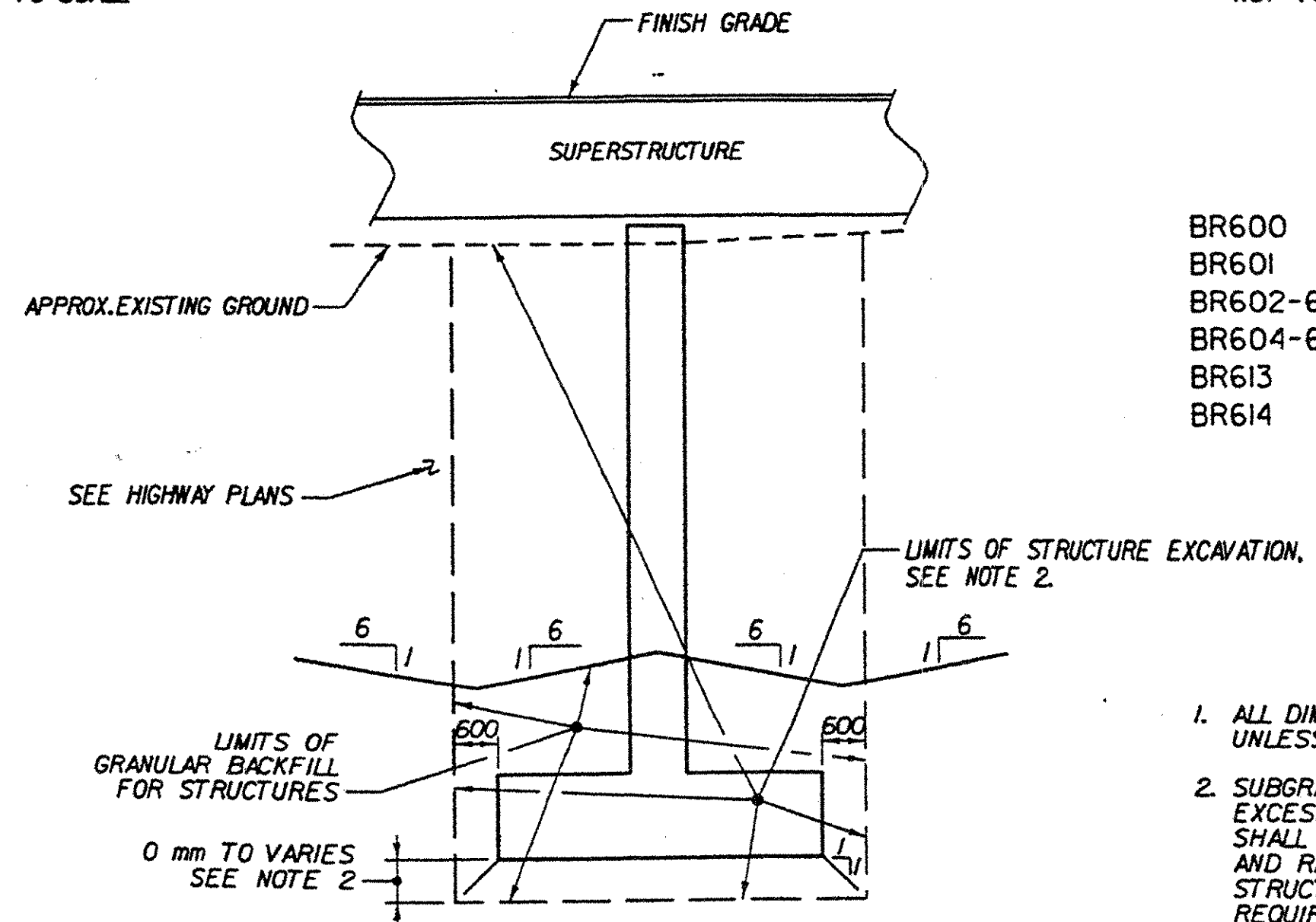

TYPICAL PIER SECTION
NOT TO SCALE

INDEX OF SHEETS

- BR600 PRELIMINARY INFORMATION SHEET
- BR601 PLAN AND ELEVATION
- BR602-603 BORING INFORMATION SHEETS
- BR604-612 BORING LOGS
- BR613 VT ROUTE 279 PROFILES
- BR614 PIER ELEVATION

NOTES:

1. ALL DIMENSIONS ARE IN MILLIMETERS (mm) UNLESS OTHERWISE NOTED.
2. SUBGRADE AREAS BENEATH FOOTINGS EXHIBITING EXCESSIVE WEAVING OR SOFT OR UNSTABLE SOILS SHALL BE REMOVED AS STRUCTURE EXCAVATION AND REPLACED WITH GRANULAR BACKFILL FOR STRUCTURES. ADDITIONAL FOUNDATION CONSTRUCTION REQUIREMENTS ARE OUTLINED IN SECTION B.D OF THE GEOTECHNICAL ENGINEERING REPORT, DATED SEPTEMBER 2000, BY GZA GEOENVIRONMENTAL, INC.

HYDROLOGIC DATA

DRAINAGE AREA: _____
 CHARACTER OF TERRAIN: _____
 CHARACTER & TYPE OF STREAM: _____
 NATURE OF STREAMBED: _____
 02.33= _____ 050= _____
 010= _____ 0100= _____
 025= _____ 0500= _____
 DATE OF FLOOD OF RECORD: _____
 WATER SURFACE ELEV.: _____ ESTIMATED DISCHARGE: _____
 NATURAL STREAM VELOCITY @ 050 = _____ mps
 ICE CONDITIONS: _____ DEBRIS: _____
 DOES THE STREAM REACH MAXIMUM HIGHWATER ELEVATION RAPIDLY? _____
 IS ORDINARY FLOOD RAPID? _____
 IS STAGE AFFECTED BY UPSTREAM OR DOWNSTREAM CONDITIONS? _____
 IF YES, DESCRIBE: _____
 WATERSHED STORAGE: _____ HEADWATERS: _____ UNIFORM THROUGHOUT WATERSHED: _____
 IMMEDIATELY ABOVE SITE: _____

PROPOSED STRUCTURE

STRUCTURE TYPE: Two span continuous curved plate girder bridge
 CLEAR SPAN (NORMAL TO STREAM): N/A
 VERTICAL CLEARANCE ABOVE STREAMBED: N/A
 WATERWAY OF FULL OPENING: N/A
 WATER SURFACE ELEV. @ 02.33= _____ VELOCITY= _____ mps
 010= _____ " = _____ mps
 025= _____ " = _____ mps
 050= _____ " = _____ mps
 0100= _____ " = _____ mps
 IS THE ROADWAY OVERTOPPED BELOW THE 0100? N/A FREQUENCY: N/A
 RELIEF ELEVATION: N/A DISCHARGE OVER ROAD @ 0100: N/A
 AVERAGE LOW ELEVATION OF SUPERSTRUCTURE: _____
 VERTICAL CLEARANCE @ 0100 = _____ m
 SCOUR: Channel = _____ N/A
 REQUIRED CHANNEL PROTECTION: N/A

EXISTING STRUCTURE

STRUCTURE TYPE: N/A YEAR BUILT: N/A
 CLEAR SPAN (NORMAL TO STREAM): N/A
 VERTICAL CLEARANCE ABOVE STREAMBED: N/A
 WATERWAY OF FULL OPENING: N/A
 DISPOSITION OF STRUCTURE: _____
 TYPE OF MATERIAL UNDER SUBSTRUCTURE: N/A
 WATER SURFACE ELEV. @ 02.33= _____ VELOCITY= _____ mps
 010= _____ " = _____ mps
 025= _____ " = _____ mps
 050= _____ " = _____ mps
 0100= _____ " = _____ mps
 LONG TERM STREAM BED CHANGES: N/A
 IS THE ROADWAY OVERTOPPED BELOW THE 0100? N/A FREQUENCY: N/A
 RELIEF ELEVATION: N/A DISCHARGE OVER ROAD @ 0100: N/A
 UPSTREAM STRUCTURE: TOWN: N/A DISTANCE: _____
 HIGHWAY NO.: _____ STRUCTURE NO.: _____
 STRUCTURE TYPE: _____
 CLEAR SPAN: _____ CLEAR HEIGHT: _____
 YEAR BUILT: _____ FULL WATERWAY: _____
 DOWNSTREAM STRUCTURE: TOWN: N/A DISTANCE: _____
 HIGHWAY NO.: _____ STRUCTURE NO.: _____
 STRUCTURE TYPE: _____
 CLEAR SPAN: _____ CLEAR HEIGHT: _____
 YEAR BUILT: _____ FULL WATERWAY: _____
 (COMPLETE INFORMATION WILL BE PROVIDED ON FINAL PLANS)

PERMIT INFORMATION

AVERAGE DAILY FLOW: N/A
 ORDINARY LOW WATER: _____ cms ELEV.: _____
 ORDINARY HIGH WATER: _____ cms ELEV.: _____

TEMPORARY BRIDGE REQUIREMENTS

STRUCTURE TYPE: N/A
 CLEAR SPAN (NORMAL TO STREAM): N/A
 VERTICAL CLEARANCE ABOVE STREAMBED: N/A
 WATERWAY OF FULL OPENING: N/A

DESIGN CRITERIA:

1. DESIGN LIVE LOAD AASHTO MS-22.5
2. DESIGN SPAN 38.9 m + 32.9 m = 71.8 m
3. ALLOWABLE LOAD FOR SPREAD FOOTINGS ON SOIL 383 kPa (Abut. 1, Pier & Abut. 2) ON LEDGE N/A
4. ALLOWABLE LOAD FOR PILING N/A TYPE N/A ESTIMATED LENGTH N/A
5. STRUCTURAL STEEL AASHTO GRADE M270M GR345W
6. REINFORCING STEEL GRADE 420
7. CONCRETE, HIGH PERFORMANCE CLASS A $f_c = 30$ MPa
 CONCRETE, HIGH PERFORMANCE CLASS B $f_c = 25$ MPa

TRAFFIC MAINTENANCE:

1. IS TRAFFIC TO BE MAINTAINED? YES IF YES, ON EXISTING STRUCTURE NO OR ON TEMPORARY BRIDGE TEMPORARY DETOUR
2. TEMPORARY BRIDGE REQUIREMENTS: ONE OR TWO WAY N/A TRAFFIC CONTROL SIGNALS REQUIRED N/A
 MINIMUM CLEAR SPAN (NORMAL TO STREAM): N/A VERTICAL CLEARANCE ABOVE STREAMBED: N/A
 WATERWAY AT FULL OPENING: N/A
 ARE SIDEWALKS REQUIRED? N/A IF SO, ON WHAT SIDE? N/A

LOAD RATING (TONS)

| LOADING LEVELS (LOAD FACTOR) | TRUCK | | | | | | |
|---------------------------------|-------|----|-----|--------|----------|----------|----------|
| | H | HS | 352 | 6 AXLE | 3A. STR. | 4A. STR. | 5A. SEMI |
| INVENTORY A = 2.17 | | | | | | | |
| POSTED A = 1.55 | | | | | | | |
| OPERATING A = 1.30 | | | | | | | |

$RF = \frac{W_{LL} - 1.3 M_{DL}}{A \times M_{LL-1}}$

STATE OF VERMONT
AGENCY OF TRANSPORTATION

Town Of **BENNINGTON** Bridge No. _____
 Highway No. _____ Log Sta. _____
 Surv. Sta. _____
EAST ROAD OVER VT ROUTE 279
PRELIMINARY INFORMATION SHEET
 Designed By **S. BURBANK** Drawn By **A. THIBAUT**
 Checked By **M. CHENETTE** Date **11/04** Bridge Design Supervisor **G. BOGUE** Date _____
 PROJECT **BENNINGTON** PROJECT NO. **NH F019-1(5)**
 DH CAD Drawing Name: ...PlotFiles\ER\VER-PI\Plot.plt Date: 11/18/2004
 Bridge Sheet No. BR600 Sheet 29 of 112

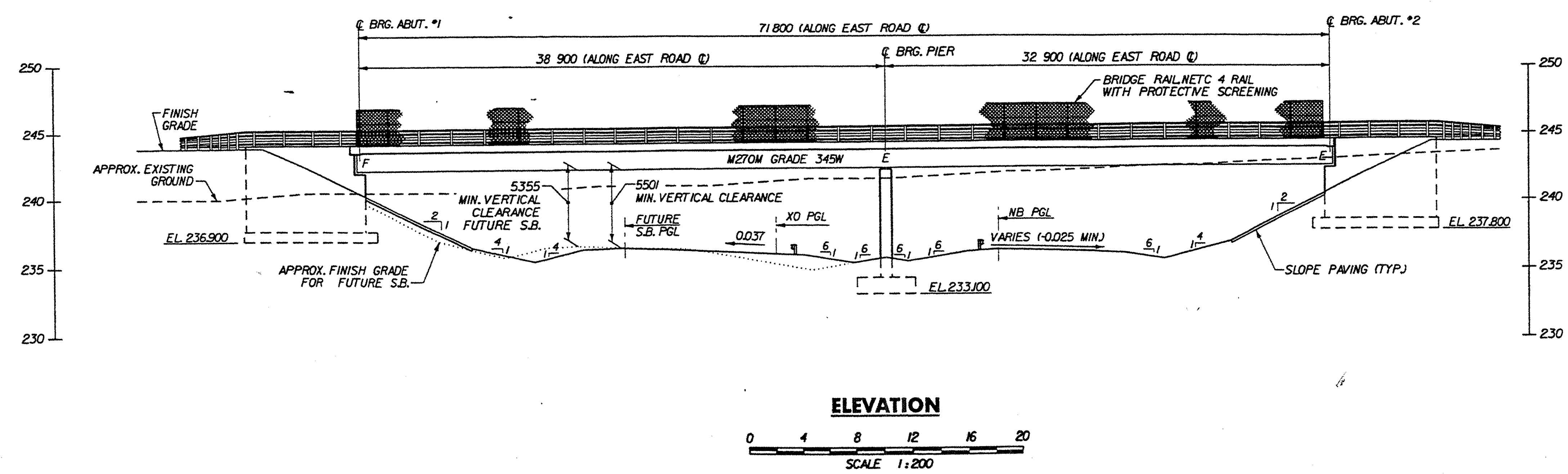
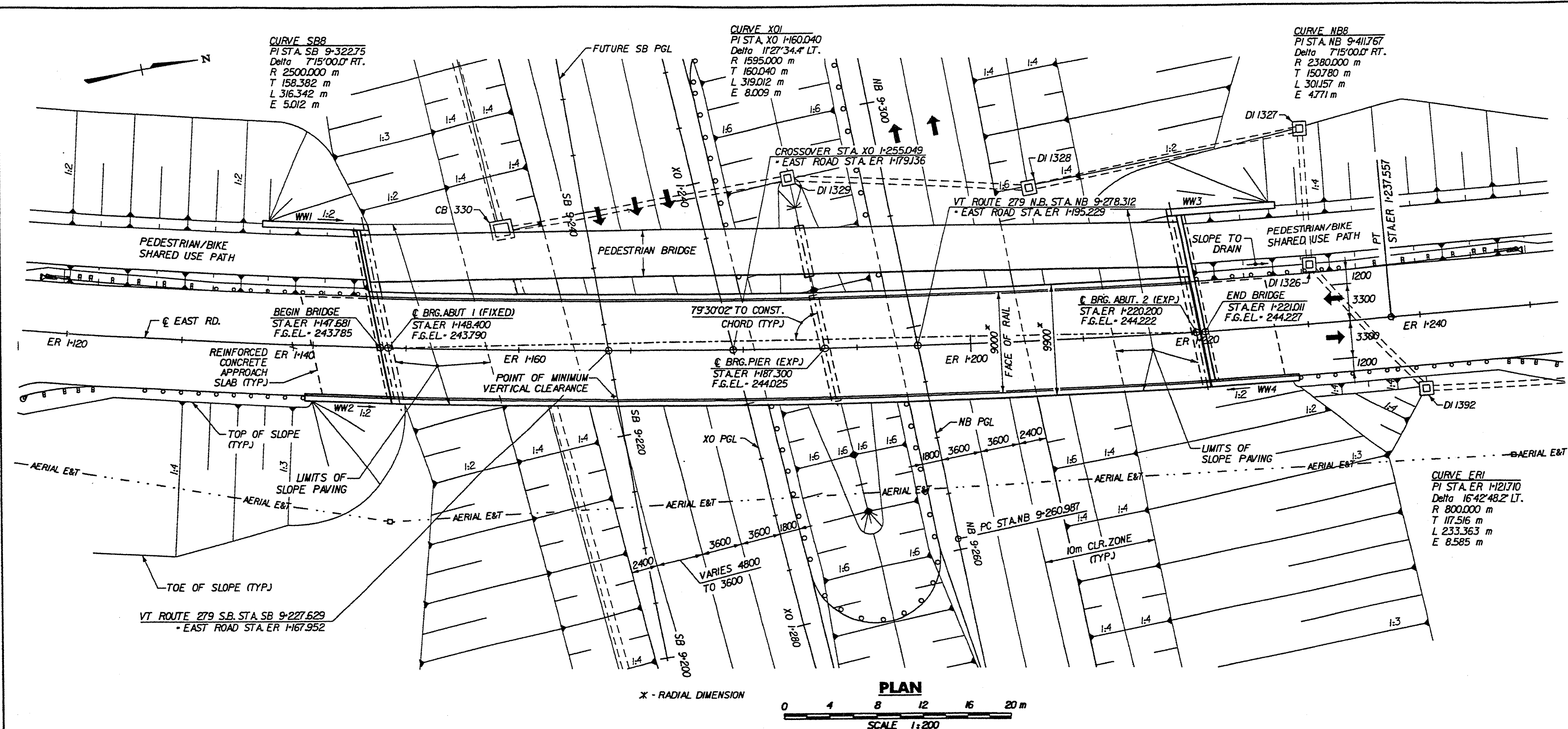

**STATE OF VERMONT
 AGENCY OF TRANSPORTATION**

| | | | |
|-------------|------------|------------|--|
| Town Of | BENNINGTON | Bridge No. | |
| Highway No. | | Log Sta. | |
| | | Surv. Sta. | |

EAST ROAD OVER VT ROUTE 279

PLAN AND ELEVATION

| | | | |
|-------------|-------------|--------------------------|-----------|
| Designed By | T. KNIGHT | Drawn By | T. KNIGHT |
| Checked By | M. CHENETTE | Date | 11/04 |
| | | Bridge Design Supervisor | G. BOGUE |
| | | Date | |

| | | | |
|---------|------------|-------------|--------------|
| PROJECT | BENNINGTON | PROJECT NO. | NH FO19-1(5) |
|---------|------------|-------------|--------------|

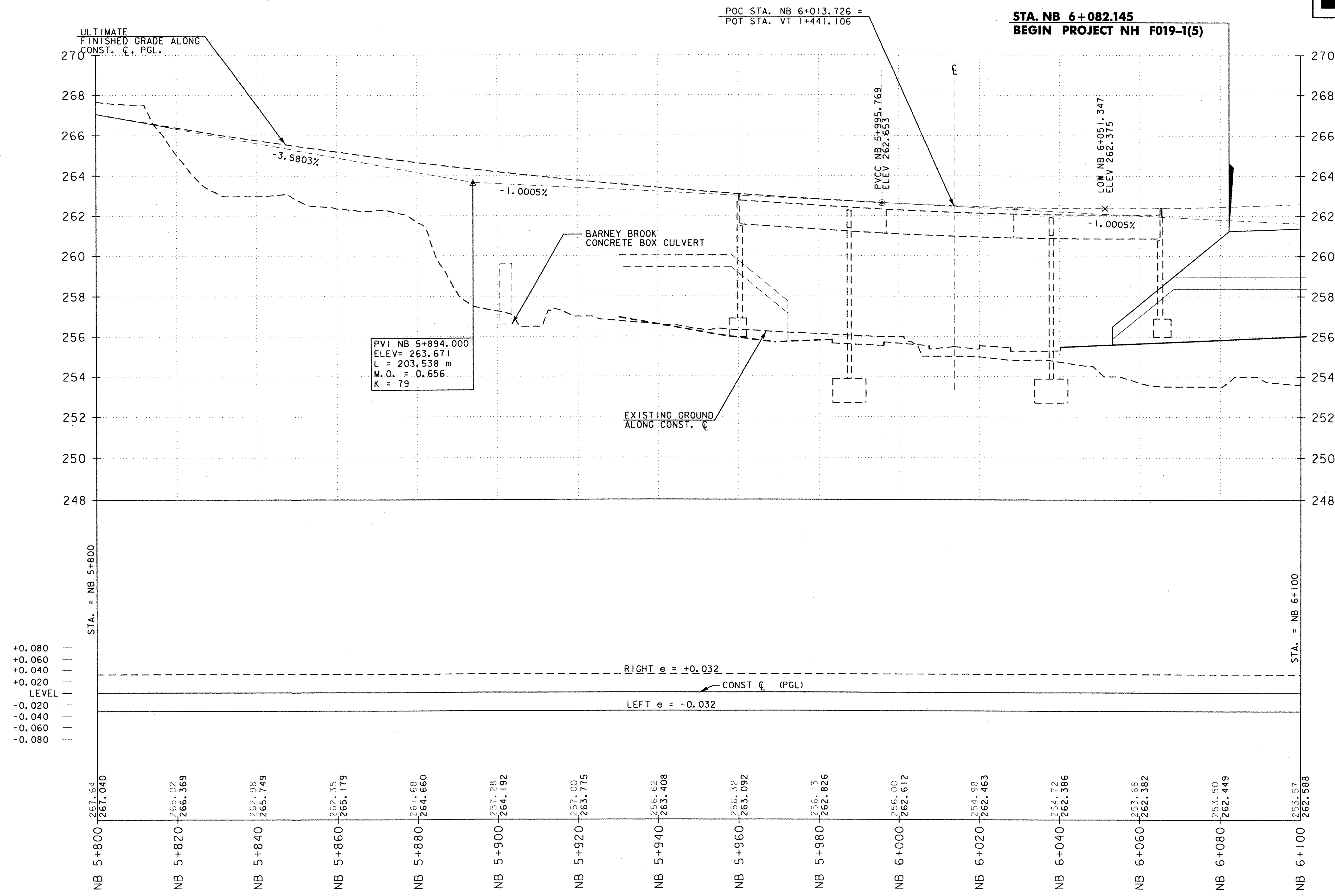

+0.080
 +0.060
 +0.040
 +0.020
 LEVEL
 -0.020
 -0.040
 -0.060
 -0.080

NOTE: FINISH GRADE SHOWN IS FOR FUTURE BUILD III. THIS PROJECT WILL BUILD TO SUBGRADE TO STATION NB 6+574.000

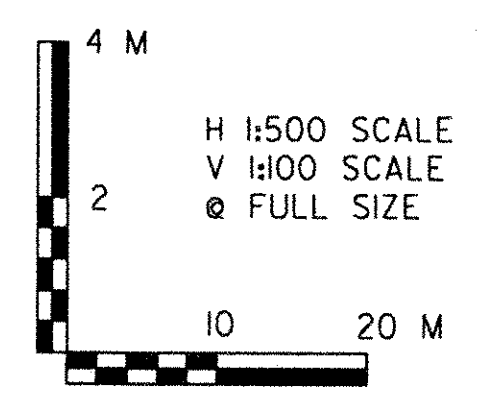

VERMONT AGENCY OF TRANSPORTATION

PROJECT NAME: BENNINGTON
 PROJECT NUMBER: NH F019-1(5)

REVISED

FILE NAME: ...PlotFiles\Profiles\mpro05.pft PLOT DATE: 11/23/2004
 DESIGN SUPERVISOR: GREG EDWARDS DRAWN BY: DUFRESNE-HENRY
 DESIGNED BY: MARC FOISY CHECKED BY: GARY SANTY
 NORTHBOUND - PR-1 SHEET 30 OF 112

K:\E80020_bennNHHighway\PlotFiles\Profiles\mpro05.pft

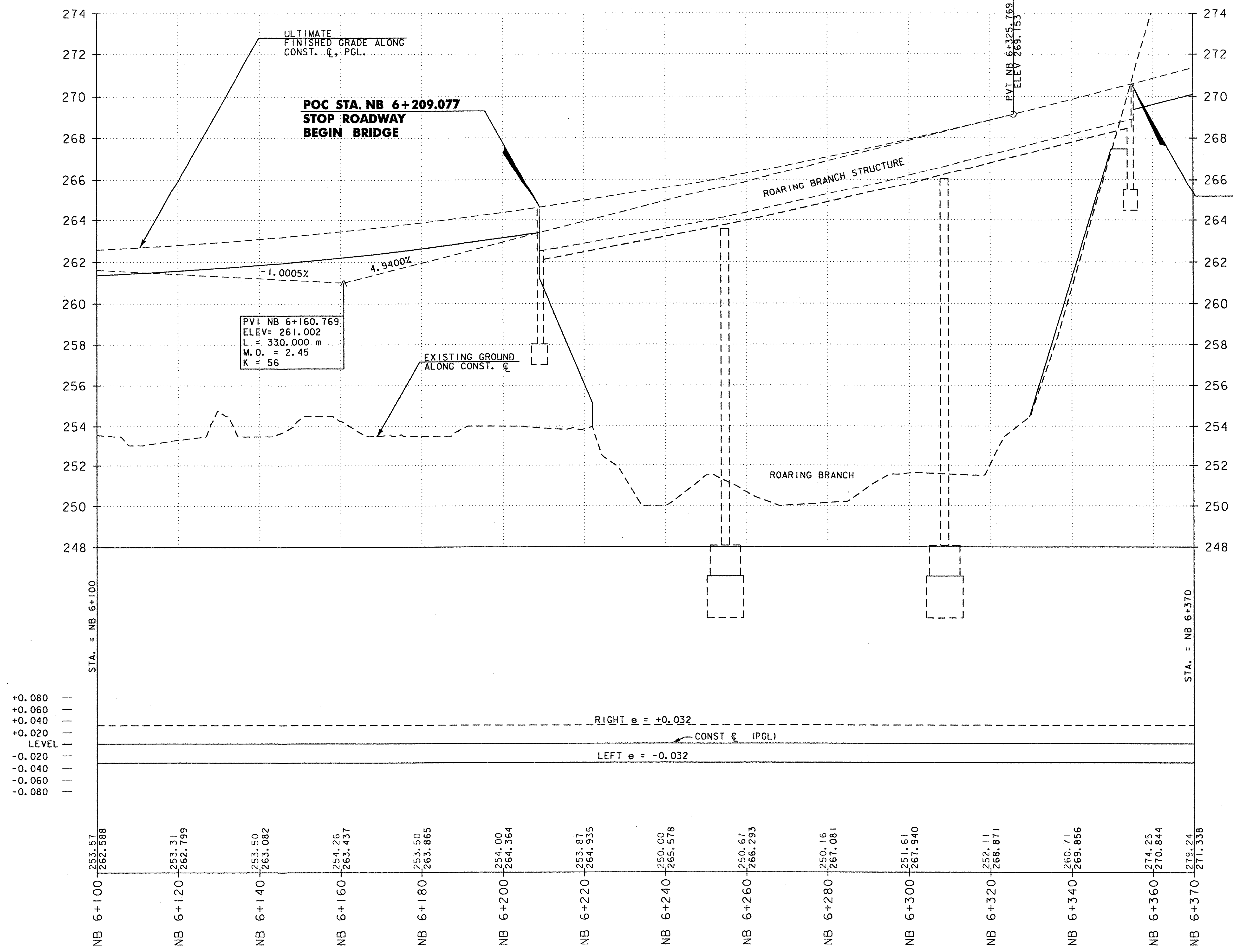

POC STA. NB 6+354.869
END BRIDGE
RESUME ROADWAY

K:\6380020 (Bennington Highway)\Plot Files\A\Profile\mp06.prf

NOTE: FINISH GRADE SHOWN IS FOR FUTURE BUILD III. THIS PROJECT WILL BUILD TO SUBGRADE TO STATION NB 6+574.000

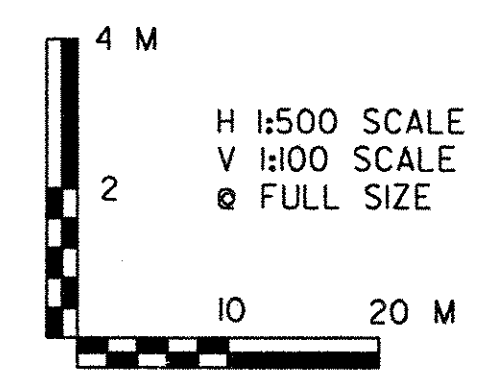

| | |
|---|------------------------------|
| VERMONT AGENCY OF TRANSPORTATION | |
| | PROJECT NAME: BENNINGTON |
| | PROJECT NUMBER: NH F019-1(5) |
| FILE NAME: ...\mp06.prf | PLOT DATE: 05/27/2003 |
| DESIGN SUPERVISOR: GREG EDWARDS | DRAWN BY: DUFRESNE-HENRY |
| DESIGNED BY: BJM/MARC FOISY | CHECKED BY: GARY SANTY |
| NORTHBOUND - PR-2 | SHEET 31 OF 112 |

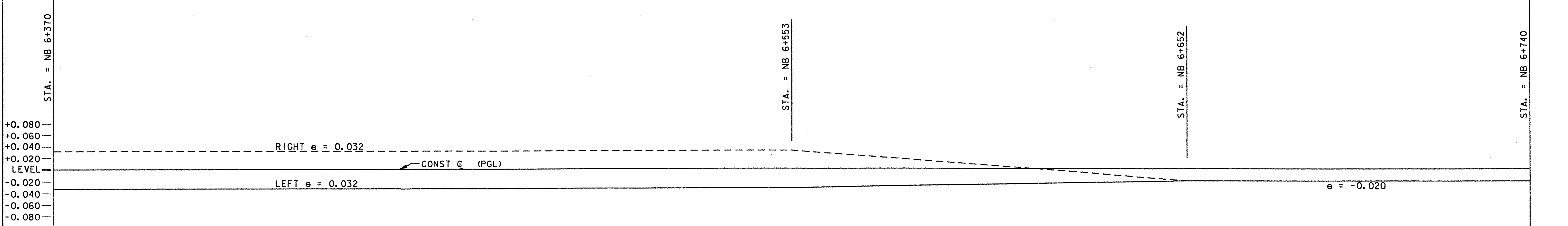
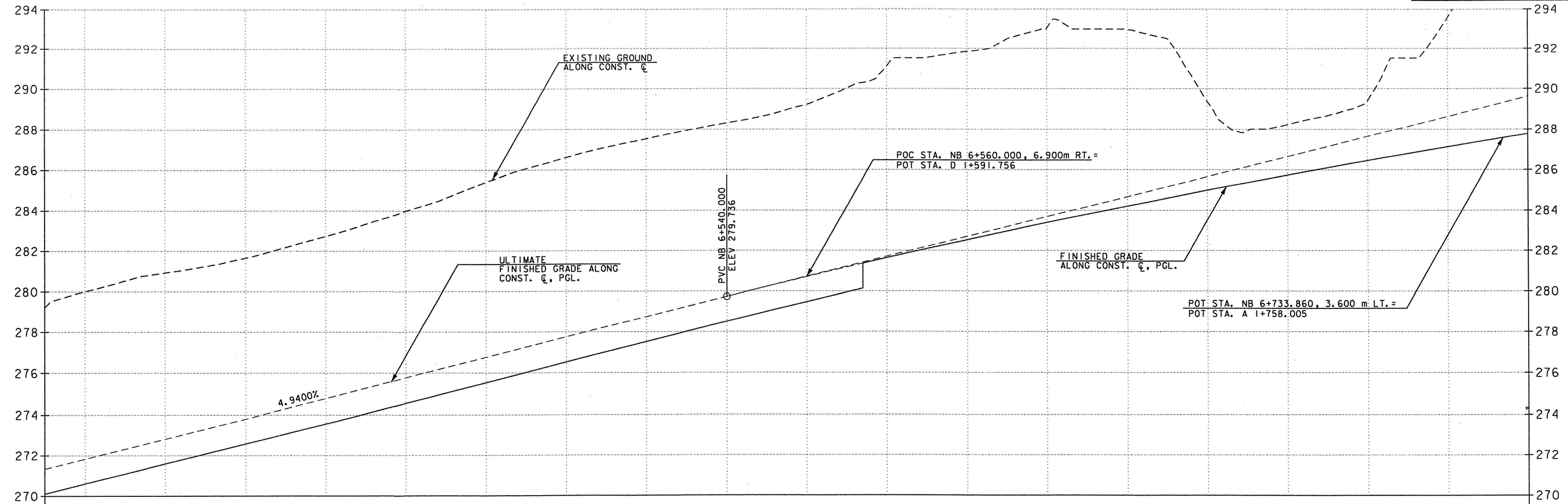

| | | | | | | | | | | | | | | | | | | | | | | | | | | | |
|----------|-------------------|----------|-------------------|----------|-------------------|----------|-------------------|----------|-------------------|----------|-------------------|----------|-------------------|----------|-------------------|----------|-------------------|----------|-------------------|----------|-------------------|----------|-------------------|----------|-------------------|----------|-------------------|
| NB 6+370 | 279.24 271.338 | NB 6+400 | 280.92 272.820 | NB 6+430 | 282.73 274.796 | NB 6+460 | 283.98 275.784 | NB 6+490 | 285.41 276.772 | NB 6+520 | 287.52 278.748 | NB 6+550 | 288.31 279.736 | NB 6+580 | 291.10 281.638 | NB 6+610 | 293.05 283.392 | NB 6+640 | 292.98 284.213 | NB 6+670 | 288.24 285.745 | NB 6+700 | 289.39 286.456 | NB 6+730 | 293.58 287.129 | NB 6+740 | 299.24 287.765 |
|----------|-------------------|----------|-------------------|----------|-------------------|----------|-------------------|----------|-------------------|----------|-------------------|----------|-------------------|----------|-------------------|----------|-------------------|----------|-------------------|----------|-------------------|----------|-------------------|----------|-------------------|----------|-------------------|

K:\AS380020 (Benning Highway)\Profile\Files\Profile\mp07.dwg

NOTE: FINISH GRADE SHOWN IS FOR FUTURE BUILD III. THIS PROJECT WILL BUILD TO SUBGRADE TO STATION NB 6+574.000

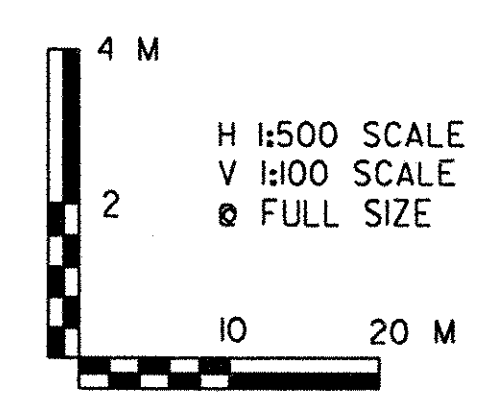

H 1:500 SCALE
V 1:100 SCALE
Ø FULL SIZE

VERMONT AGENCY OF TRANSPORTATION



PROJECT NAME: BENNINGTON
PROJECT NUMBER: NH F019-1(5)

FILE NAME: ...\mp07.dwg
DESIGN SUPERVISOR: GREG EDWARDS
DESIGNED BY: BJM/MARC FOISY
NORTHBOUND - PR-3

PLOT DATE: 05/27/2003
DRAWN BY: DUFRESNE-HENRY
CHECKED BY: GARY SANTY
SHEET 32 OF 112

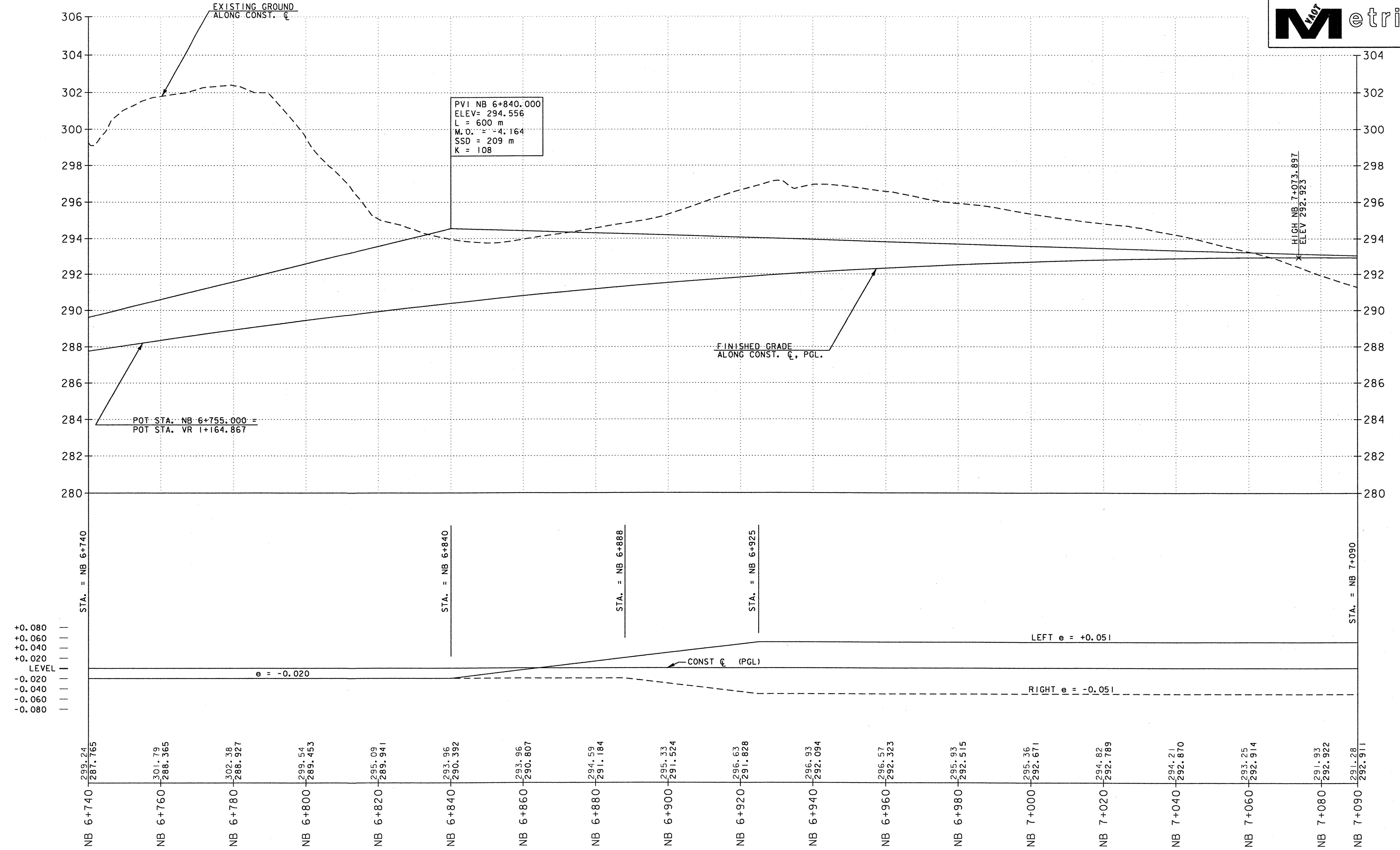

LEVEL
+0.080
+0.060
+0.040
+0.020
-0.020
-0.040
-0.060
-0.080

R:\6380020 (Bennington)Highway\PlotFiles\vr of final\mplpro08.prf

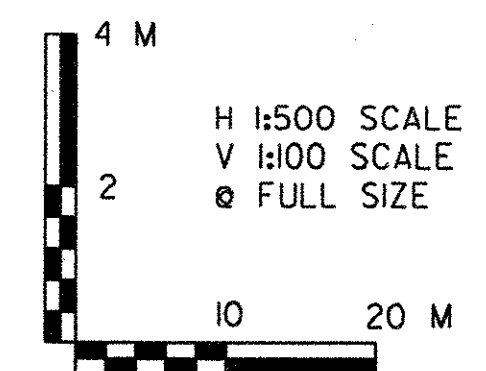

VERMONT AGENCY OF TRANSPORTATION

| | |
|---------------------------------|--------------------------|
| PROJECT NAME: BENNINGTON | PLOT DATE: 05/27/2003 |
| PROJECT NUMBER: NH F019-1(5) | DRAWN BY: DUFRESNE-HENRY |
| FILE NAME: ...\mplpro08.prf | CHECKED BY: GARY SANTY |
| DESIGN SUPERVISOR: GREG EDWARDS | SHEET 33 OF 112 |
| DESIGNED BY: BJM/MARC FOISY | |

NORTHBOUND - PR-4

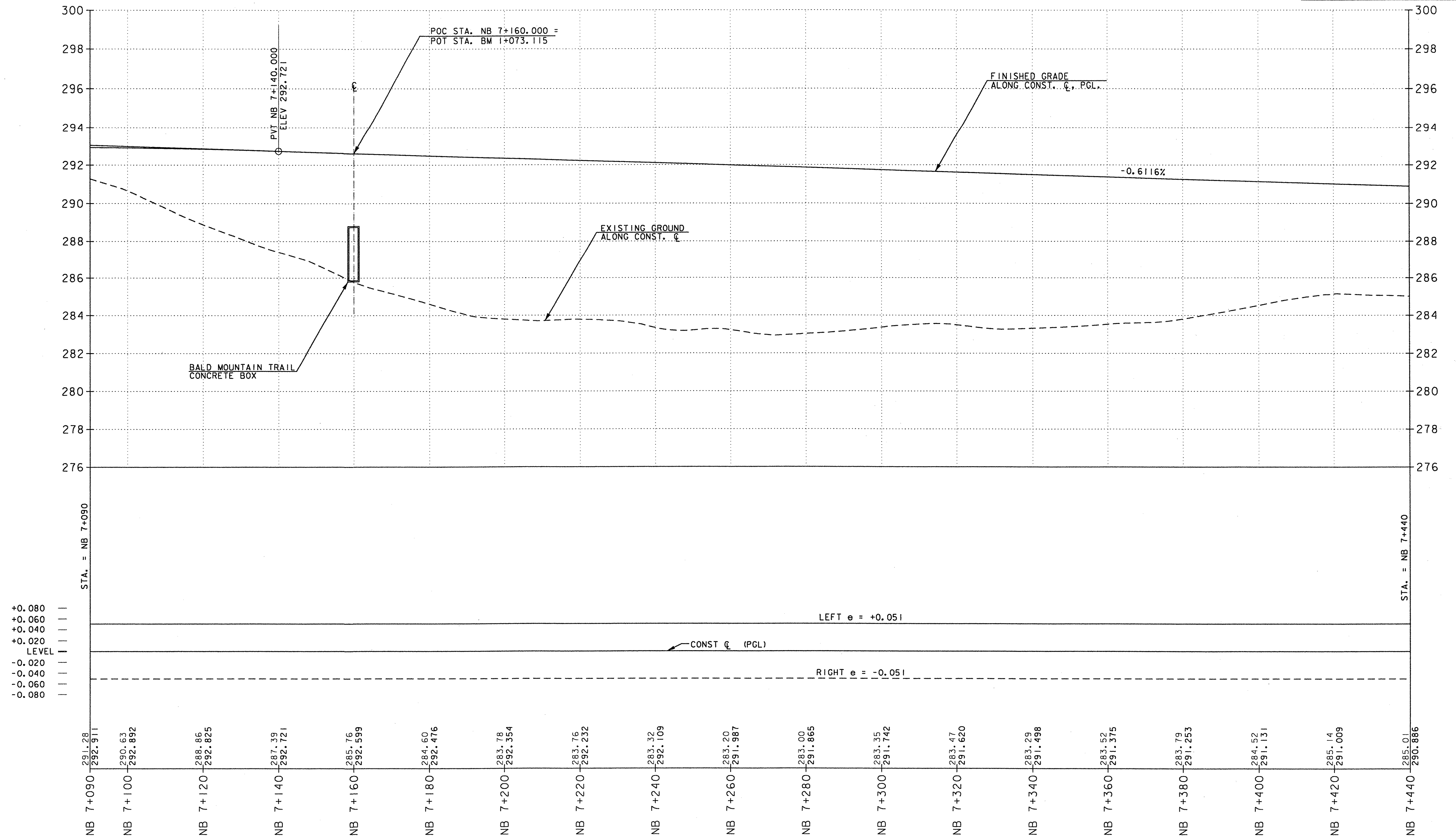

LEVEL
 +0.080
 +0.060
 +0.040
 +0.020
 -0.020
 -0.040
 -0.060
 -0.080

STA. = NB 7+090

STA. = NB 7+440

LEFT e = +0.051

RIGHT e = -0.051

CONST C (PGL)

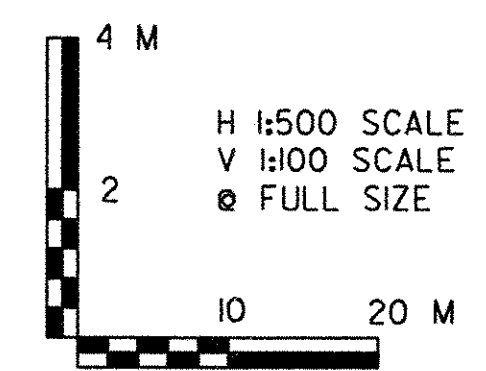

VERMONT AGENCY OF TRANSPORTATION



PROJECT NAME: BENNINGTON
 PROJECT NUMBER: NH F019-1(5)
 FILE NAME: ...\mipro09.pptf
 DESIGN SUPERVISOR: GREG EDWARDS
 DESIGNED BY: BJM/MARC FOISY
 PLOT DATE: 05/27/2003
 DRAWN BY: DUFRESNE-HENRY
 CHECKED BY: GARY SANTY
 NORTHBOUND - PR-5
 SHEET 34 OF 112

K:\6380020 (Benn)\Highway\Profile\Files\mipro09.pptf

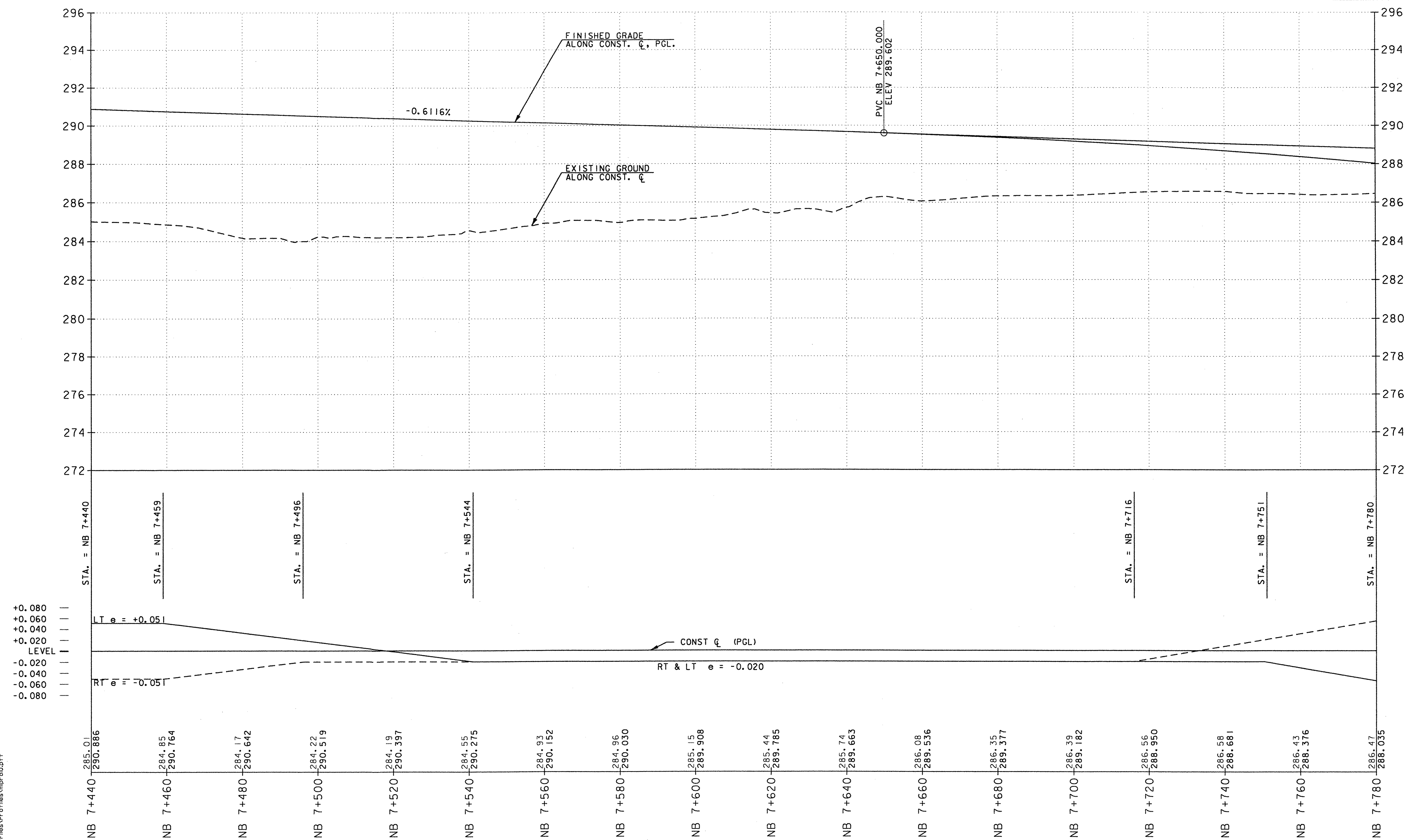

K:\6380020 (Bennington Highway)\Files\Profiles\mp010.prf

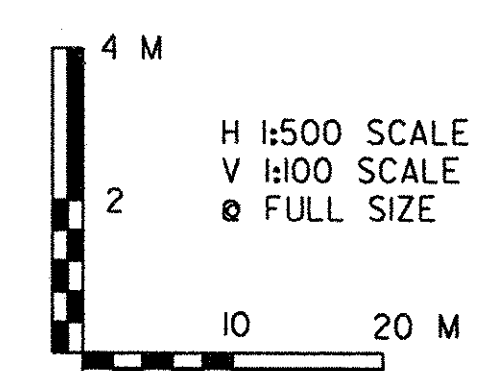

VERMONT AGENCY OF TRANSPORTATION



PROJECT NAME: BENNINGTON
 PROJECT NUMBER: NH F019-K(5)
 FILE NAME: ...\mp010.prf
 DESIGN SUPERVISOR: GREG EDWARDS
 DESIGNED BY: BJM/MARC FOISY
 NORTHBOUND - PR-6
 PLOT DATE: 05/27/2003
 DRAWN BY: DUFRESNE-HENRY
 CHECKED BY: GARY SANTY
 SHEET 35 OF 112

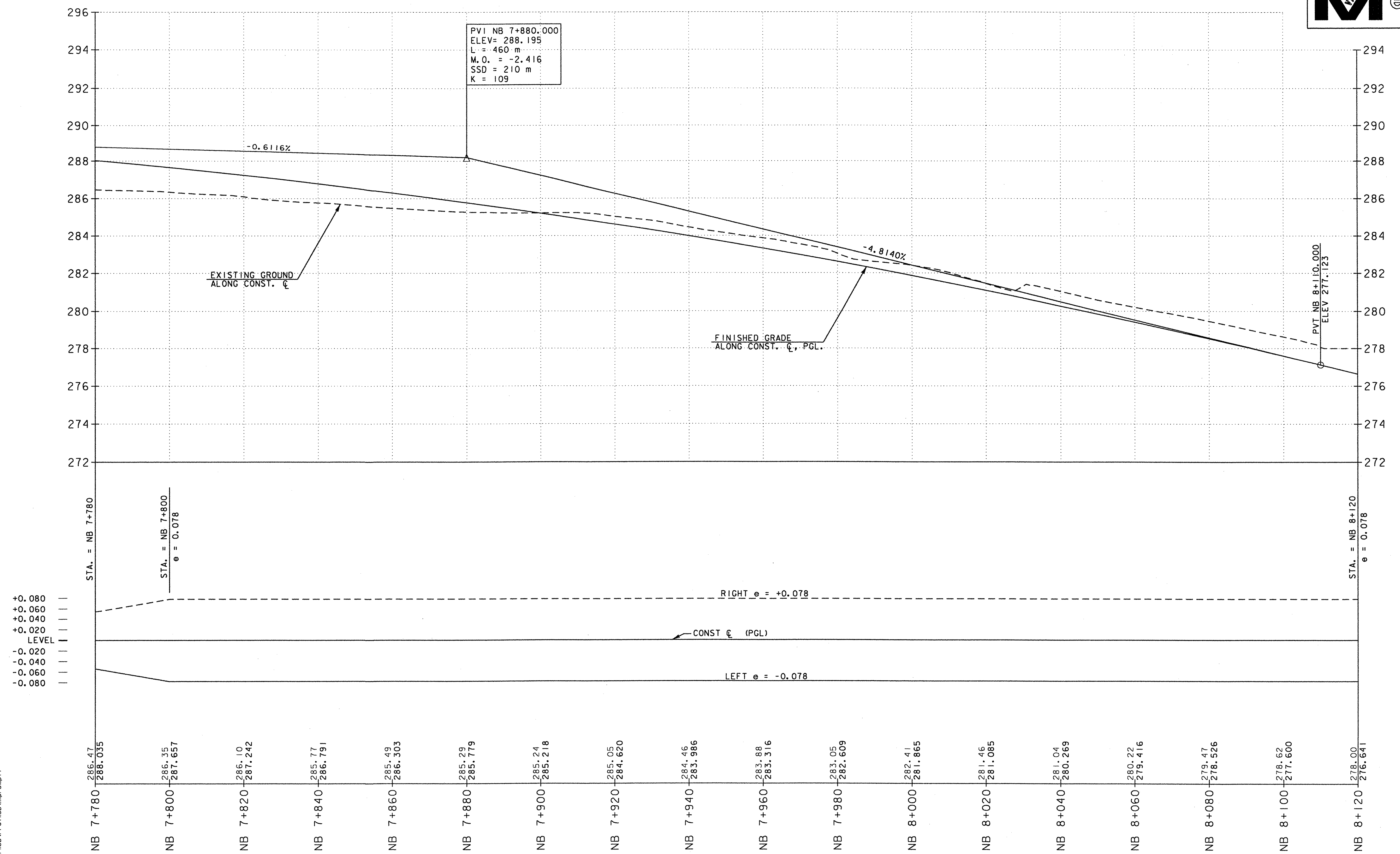

K:\V380020 (Benning)Highway\Profile\Files\Profile.mpr.plt

LEVEL
+0.080
+0.060
+0.040
+0.020
-0.020
-0.040
-0.060
-0.080

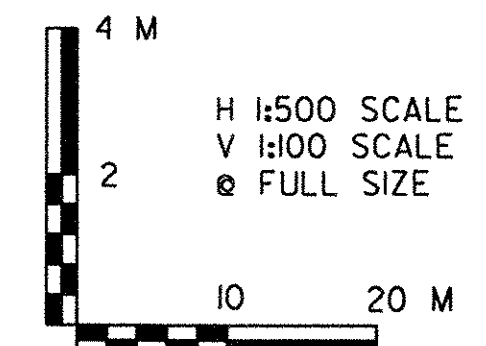

| | |
|---|------------------------------|
| VERMONT AGENCY OF TRANSPORTATION | |
| DH Dufresne-Henry | PROJECT NAME: BENNINGTON |
| | PROJECT NUMBER: NH FO19-1(5) |
| FILE NAME: ...\mproll.plt | PLOT DATE: 05/27/2003 |
| DESIGN SUPERVISOR: GREG EDWARDS | DRAWN BY: DUFRESNE-HENRY |
| DESIGNED BY: BJM/MARC FOISY | CHECKED BY: GARY SANTY |
| NORTHBOUND - PR-7 | |

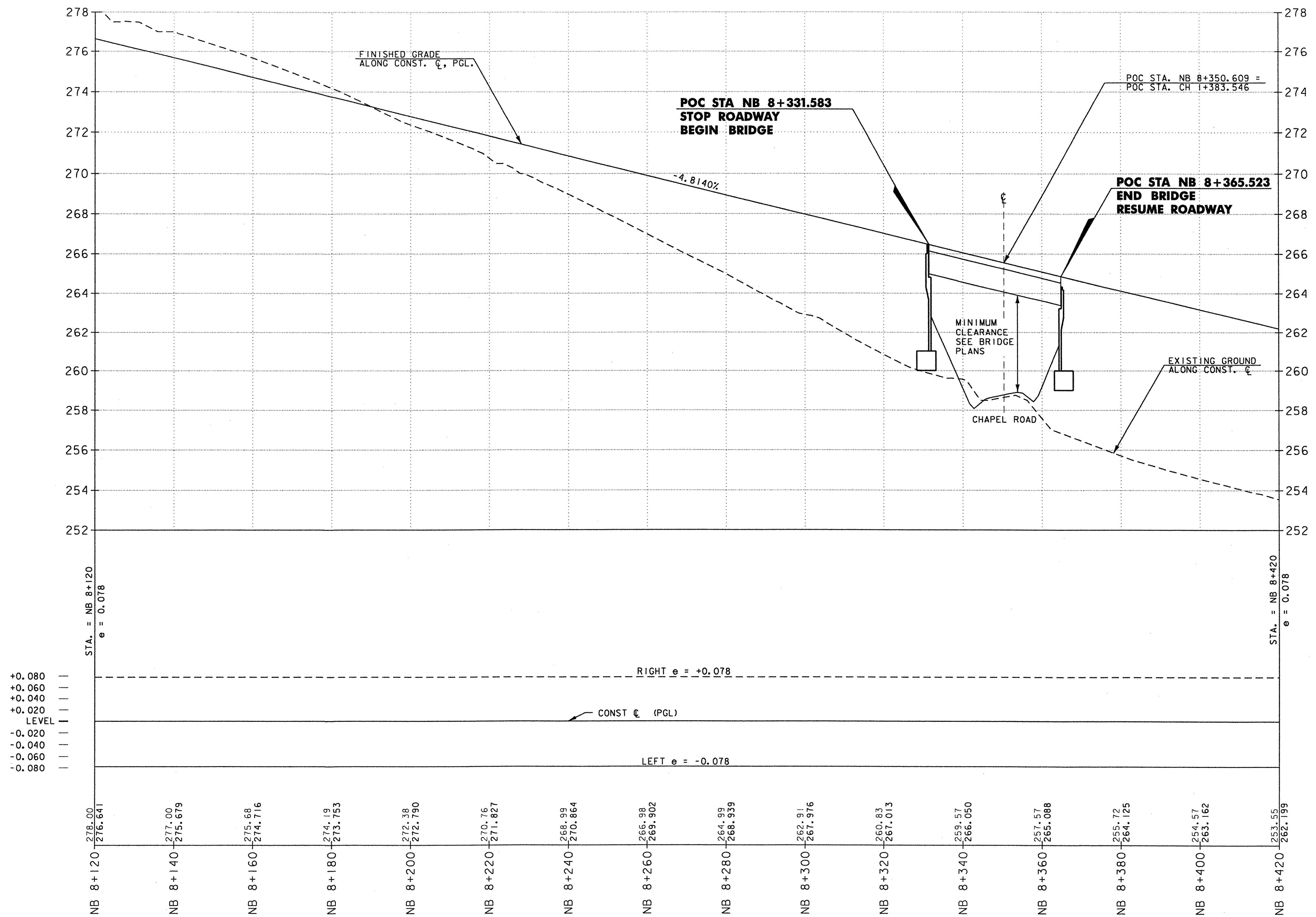

LEVEL
+0.080
+0.060
+0.040
+0.020
-0.020
-0.040
-0.060
-0.080

K:\6380020 (Barn)\Highway\PlotFiles\A\Profile.mpr02.plt

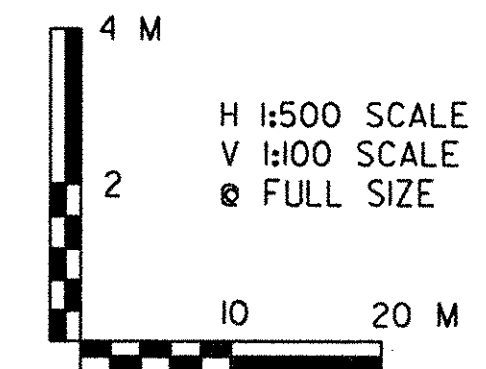

VERMONT AGENCY OF TRANSPORTATION



PROJECT NAME: BENNINGTON
 PROJECT NUMBER: NH FO19-(K5)
 FILE NAME: ...\mpl02.plt
 DESIGN SUPERVISOR: GREG EDWARDS
 DESIGNED BY: BJM/MARC FOISY
 NORTHBOUND - PR-8

PLOT DATE: 05/27/2003
 DRAWN BY: DUFRESNE-HENRY
 CHECKED BY: GARY SANTY
 SHEET 37 OF 112

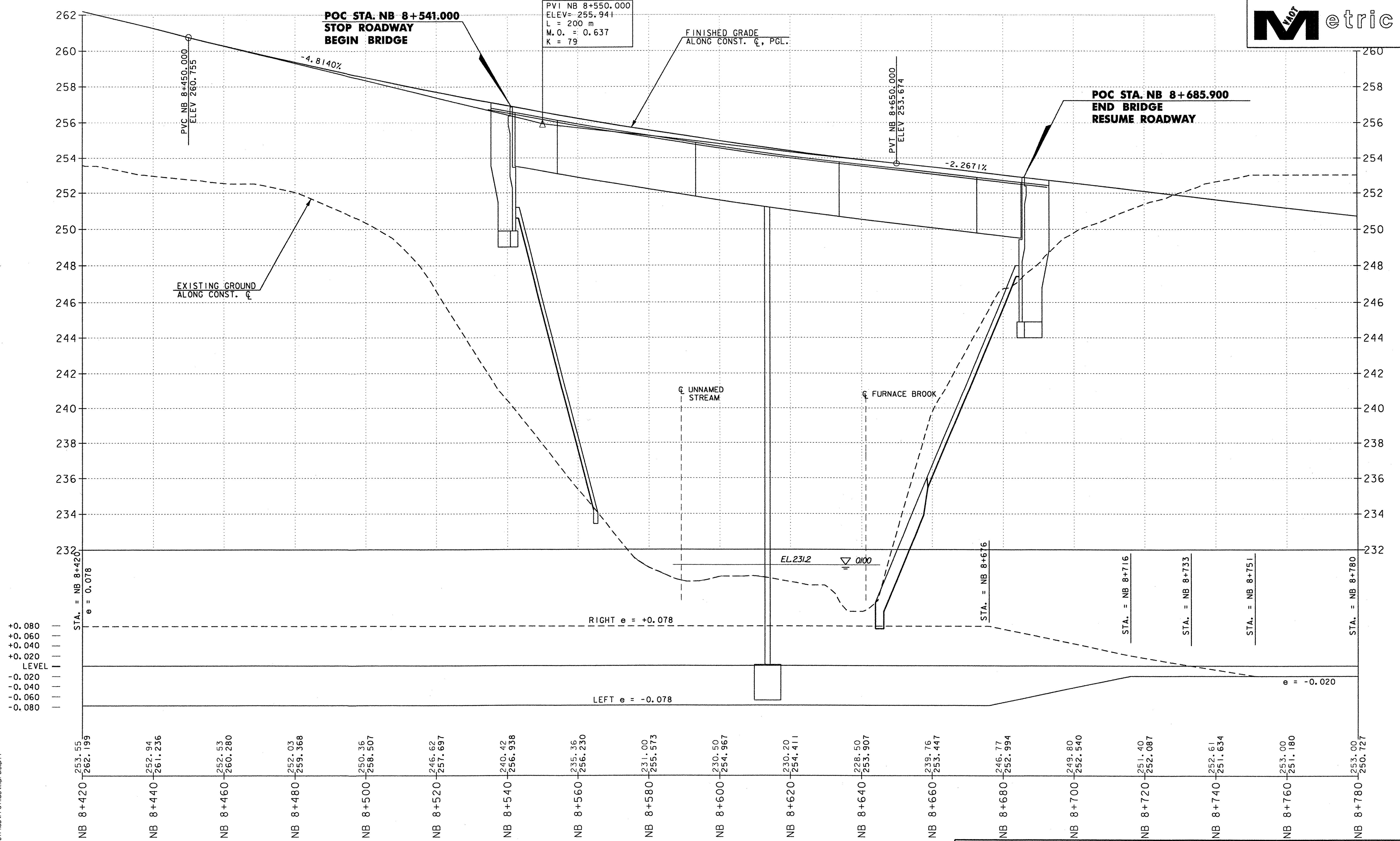

r:\6380020 (Bennington Highway)\ProjFiles\Asst\Prof\files\mipr013.prf

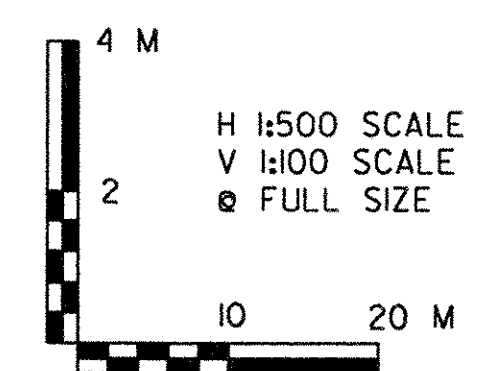

| | |
|---|------------------------------|
| VERMONT AGENCY OF TRANSPORTATION | |
| | PROJECT NAME: BENNINGTON |
| | PROJECT NUMBER: NH F019-1(5) |
| FILE NAME: ...\mipr013.prf | PLOT DATE: 05/27/2003 |
| DESIGN SUPERVISOR: GREG EDWARDS | DRAWN BY: DUFRESNE-HENRY |
| DESIGNED BY: BJM/MARC FOISY | CHECKED BY: GARY SANTY |
| NORTHBOUND - PR-9 | |
| SHEET 38 OF 112 | |

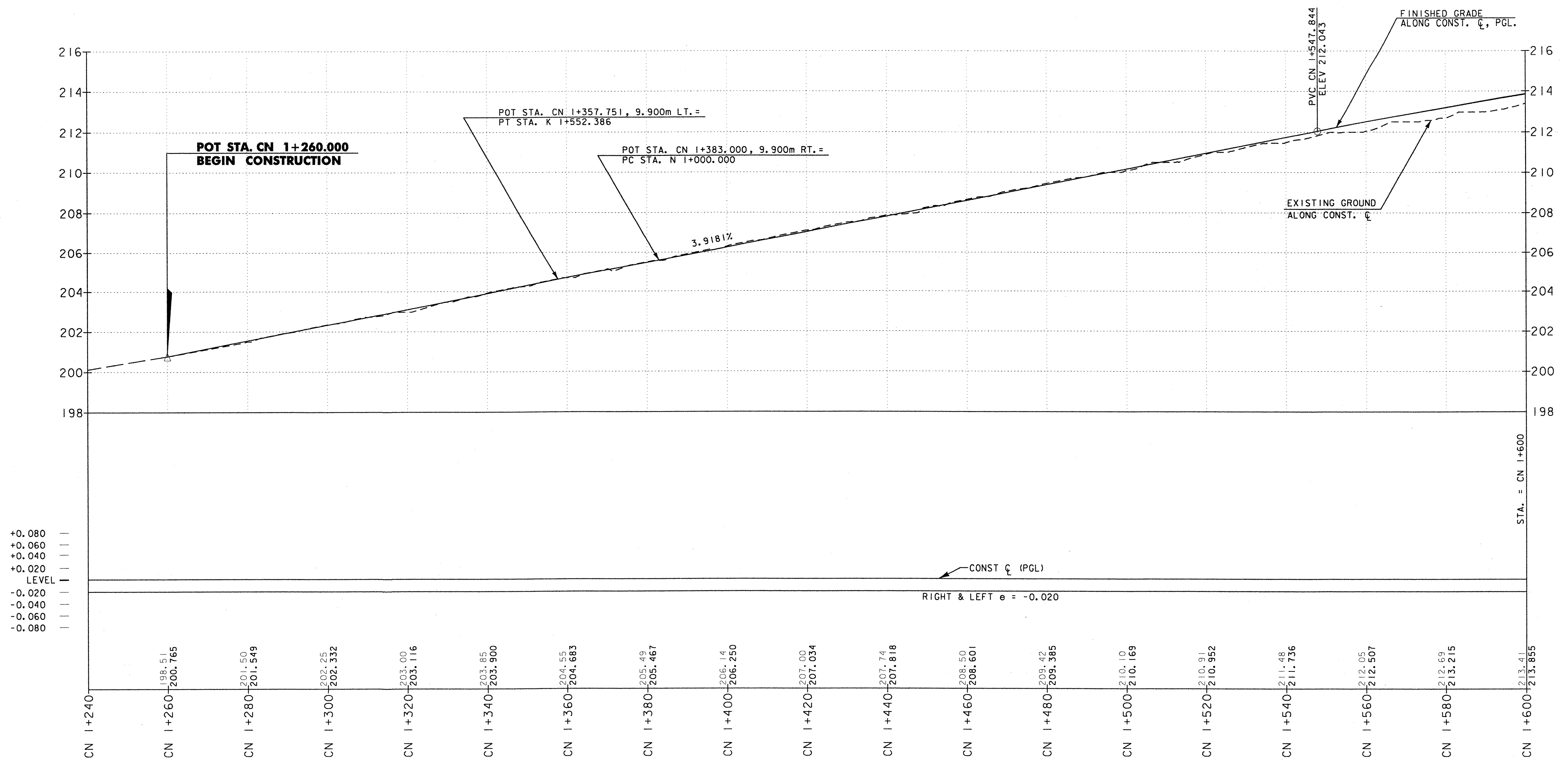

K:\638020\Bennington\Highway\PlotFiles\Profile\VTConnector.plt

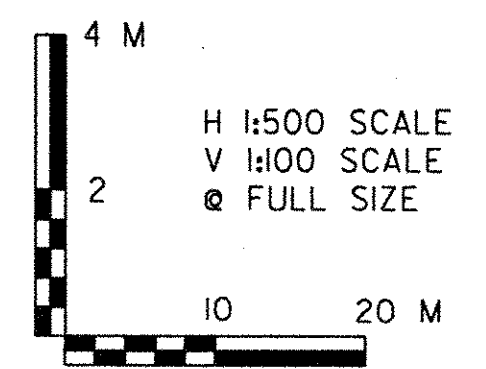

| | |
|---|---|
| VERMONT AGENCY OF TRANSPORTATION | |
| | PROJECT NAME: BENNINGTON PROJECT NUMBER: NH FO19-1(5) |
| | REVISED |
| FILE NAME: ...Profiles\RT7Connector.plt DESIGN SUPERVISOR: GREG EDWARDS DESIGNED BY: MARC FOISY | PLOT DATE: 11/20/2004 DRAWN BY: DUFRESNE-HENRY CHECKED BY: GARY SANTY |
| ROUTE 7 CONNECTOR - PR-23 | |

POT STA. A 1+000.000=
POC STA. VT 1+345.000,495.0m LT.

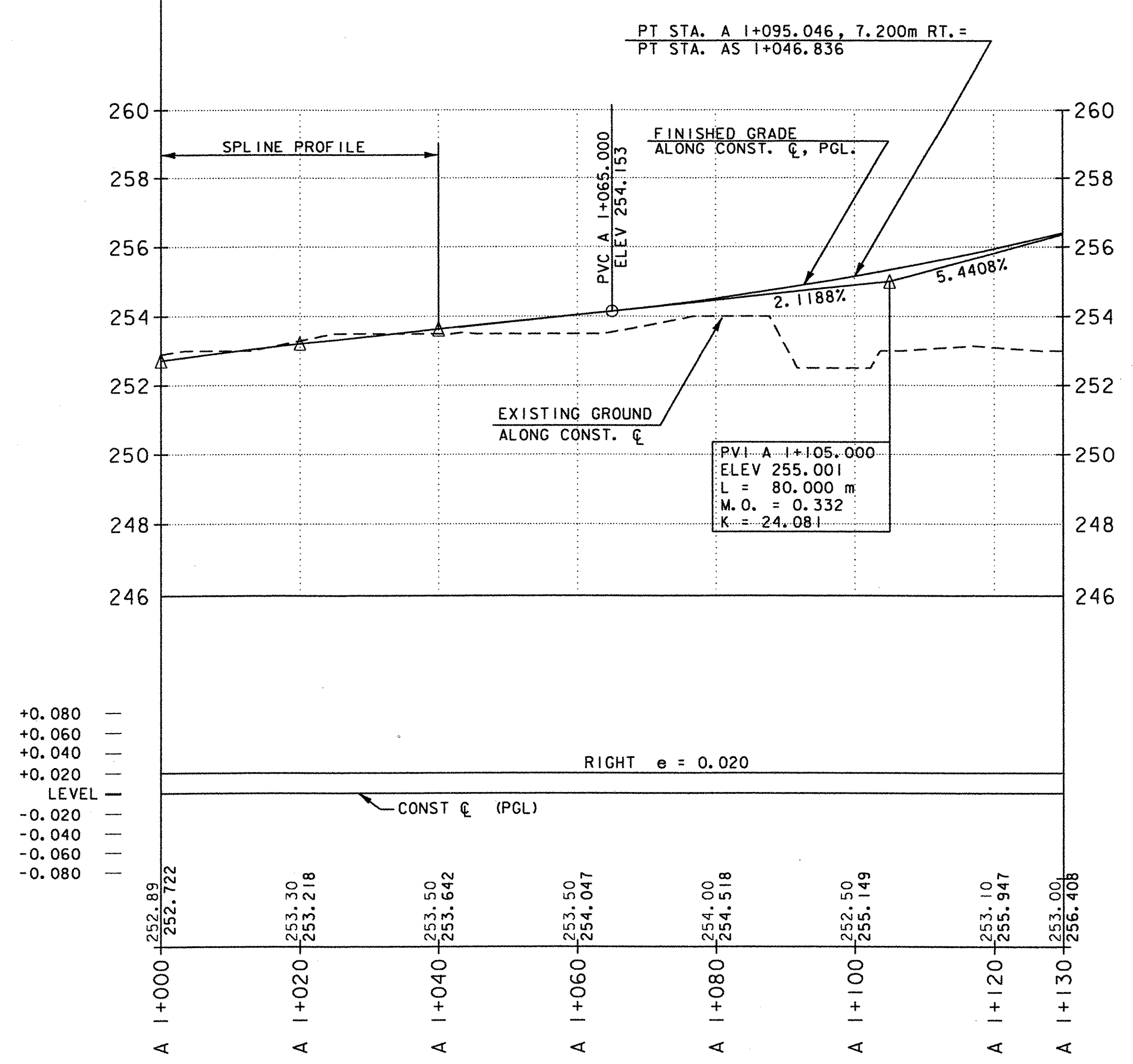

K:\6380020 (benn)\highway\plot files\profiles\ampc.prf

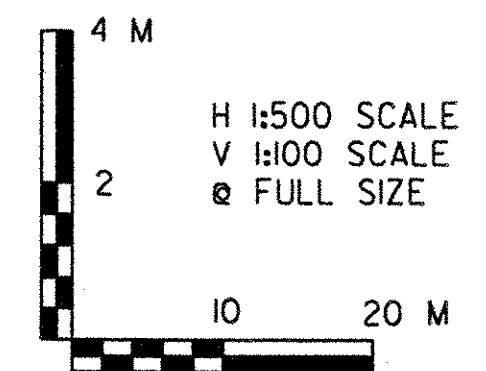

| | |
|---|------------------------------|
| VERMONT AGENCY OF TRANSPORTATION | |
| DH Dufresne-Henry | PROJECT NAME: BENNINGTON |
| | PROJECT NUMBER: NH F019-1(5) |
| FILE NAME: ...rampa.prf | PLOT DATE: 05/27/2003 |
| DESIGN SUPERVISOR: GREG EDWARDS | DRAWN BY: DUFRESNE-HENRY |
| DESIGNED BY: BJM/MARC FOISY | CHECKED BY: GARY SANTY |
| RAMP A - PR-33 | SHEET 40 OF 112 |

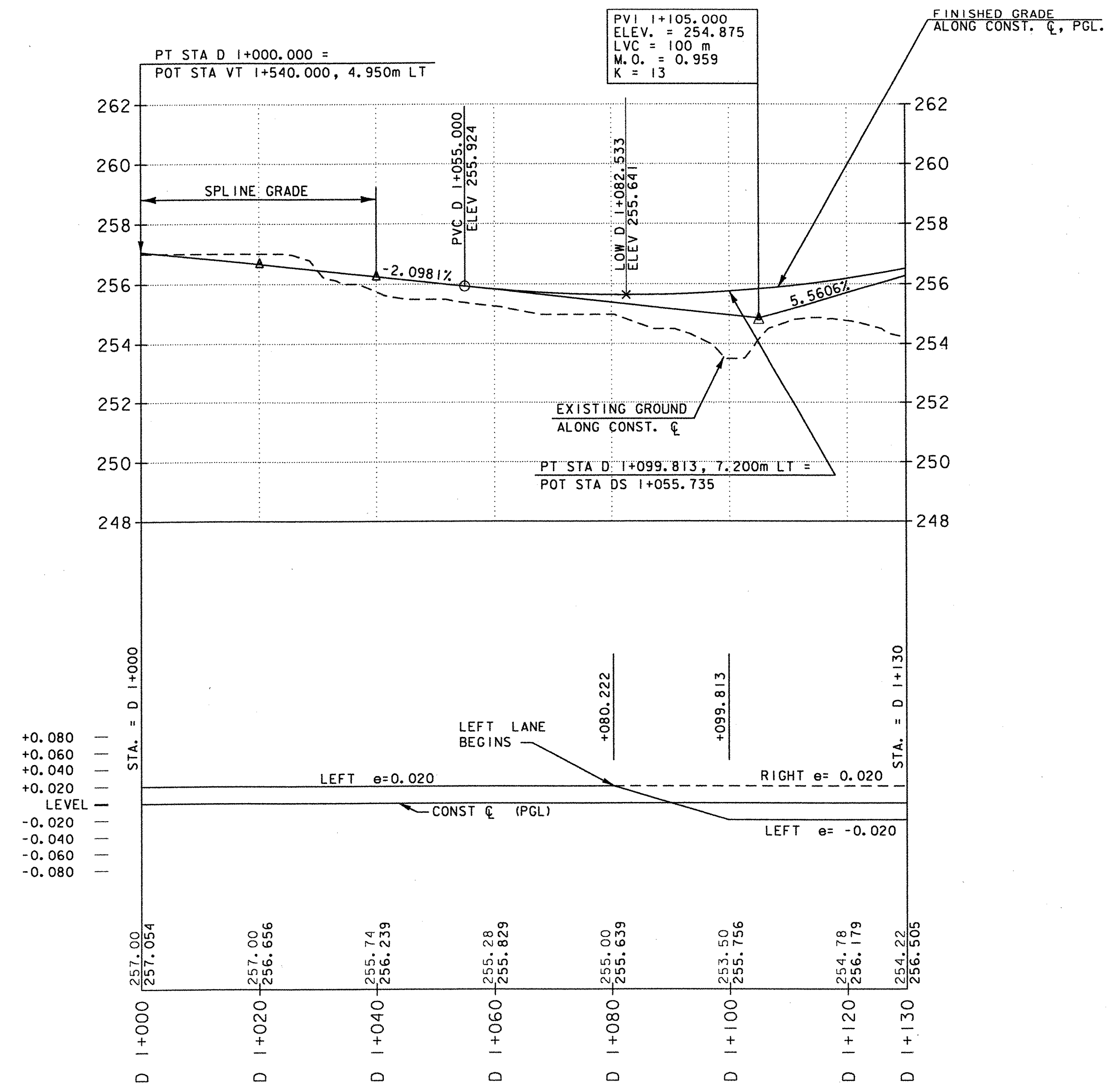

K:\636020 (Barn)Highway\ProFiles\ProFiles\RampD.pff

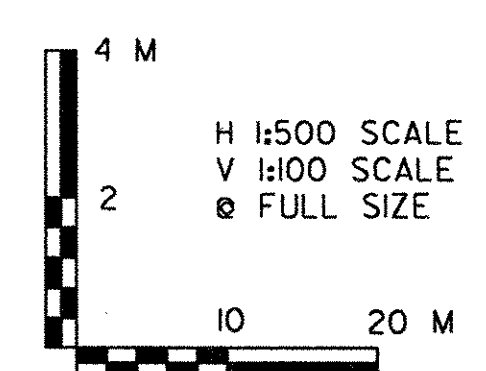

| | |
|---|------------------------------|
| VERMONT AGENCY OF TRANSPORTATION | |
| | PROJECT NAME: BENNINGTON |
| | PROJECT NUMBER: NH FO19-K(5) |
| | FILE NAME: ...RampD.pff |
| | PLOT DATE: 05/28/2003 |
| DESIGN SUPERVISOR: GREG EDWARDS | DRAWN BY: DUFRESNE-HENRY |
| DESIGNED BY: BJM/MARC FOISY | CHECKED BY: GARY SANTY |
| RAMP D - PR-37 | SHEET 41 OF 112 |

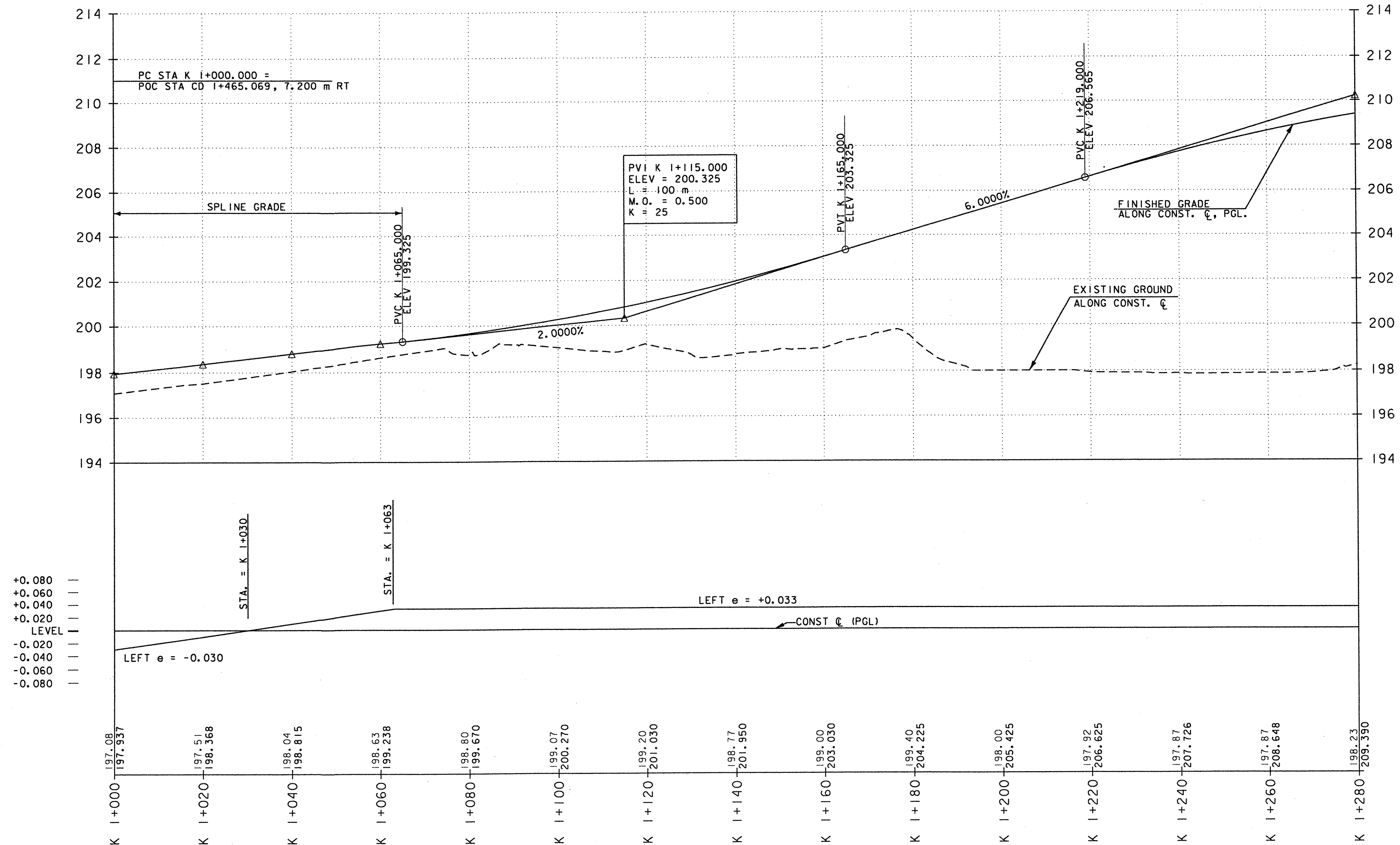

K:\A6380020 (Benn)\Highway\Profile\Files\RampK.plt

LEVEL
+0.080
+0.060
+0.040
+0.020
-0.020
-0.040
-0.060
-0.080

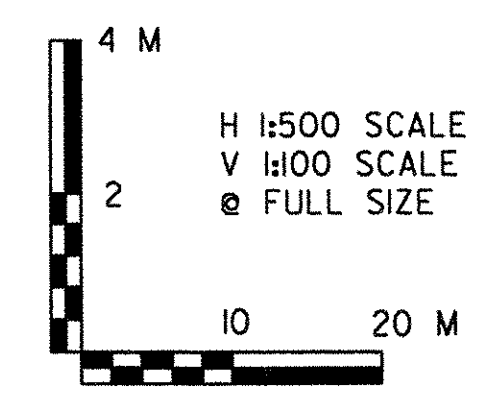

VERMONT AGENCY OF TRANSPORTATION

| | |
|---------------------------------|--------------------------|
| PROJECT NAME: BENNINGTON | PLOT DATE: 05/27/2003 |
| PROJECT NUMBER: NH FO19-1(5) | DRAWN BY: DUFRESNE-HENRY |
| FILE NAME: ...RampK.plt | CHECKED BY: GARY SANTY |
| DESIGN SUPERVISOR: GREG EDWARDS | SHEET 42 OF 112 |
| DESIGNED BY: BJM/MARC FOISY | |
| RAMP K - PR-45 | |

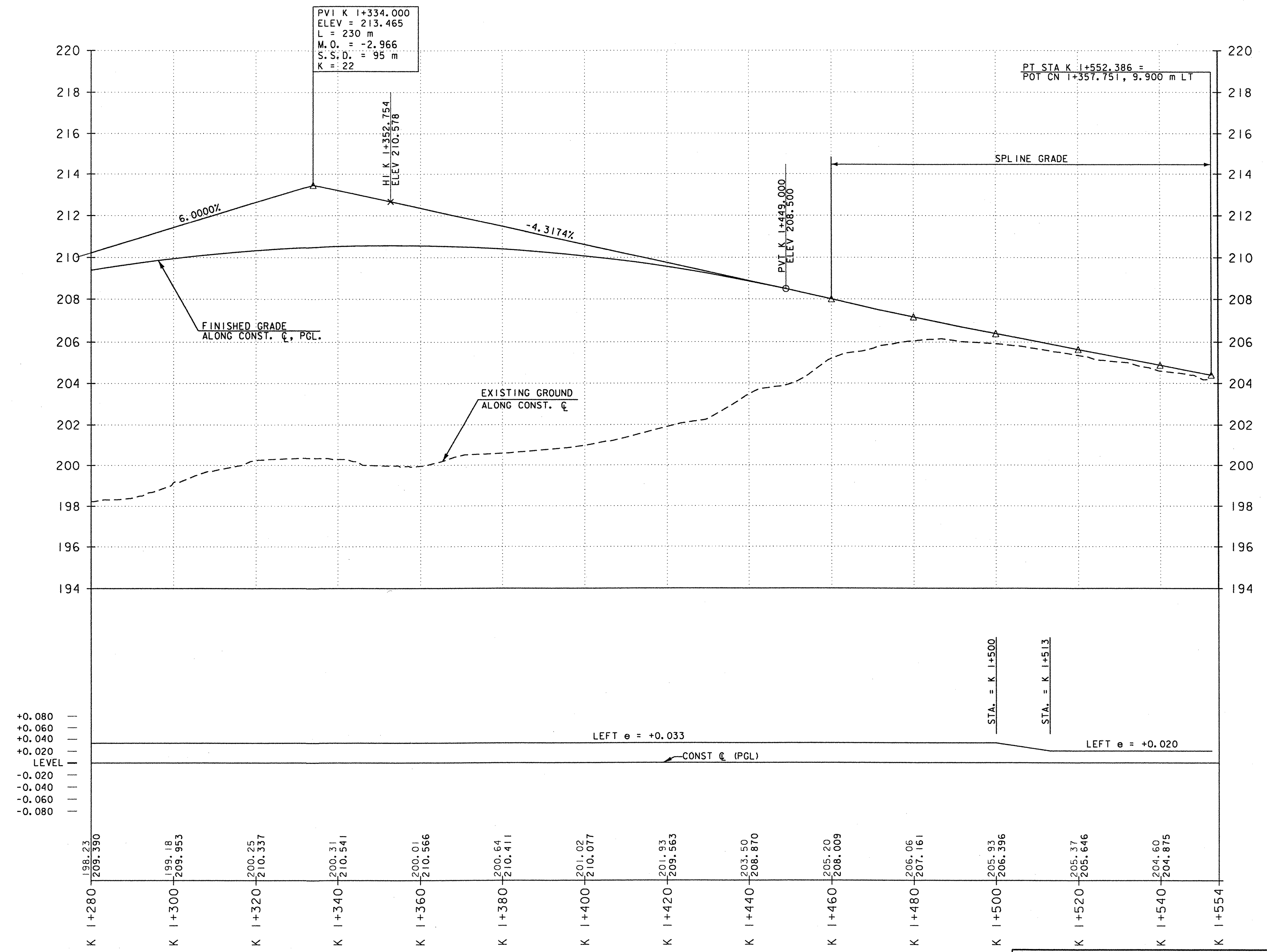

K:\6380020 (Benn)\Highway\Plots\Files\Profile\K.ramp.k.plt

LEVEL
 +0.080
 +0.060
 +0.040
 +0.020
 -0.020
 -0.040
 -0.060
 -0.080

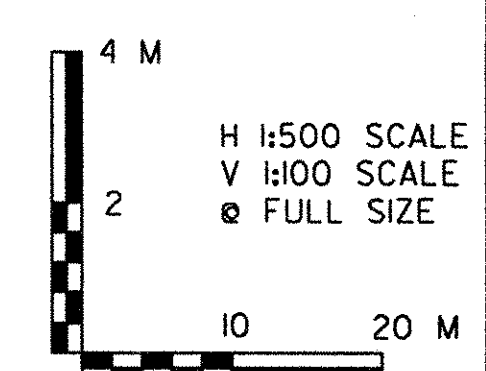

VERMONT AGENCY OF TRANSPORTATION

DH
Dufresne-Henry

| | |
|---------------------------------|--------------------------|
| PROJECT NAME: BENNINGTON | PLOT DATE: 05/27/2003 |
| PROJECT NUMBER: NH F019-1(5) | DRAWN BY: DUFRESNE-HENRY |
| FILE NAME: ...RampK.plt | DESIGNED BY: GARY SANTY |
| DESIGN SUPERVISOR: GREG EDWARDS | CHECKED BY: GARY SANTY |
| DESIGNED BY: BJM/MARC FOISY | SHEET 43 OF 112 |

RAMP K - PR-46

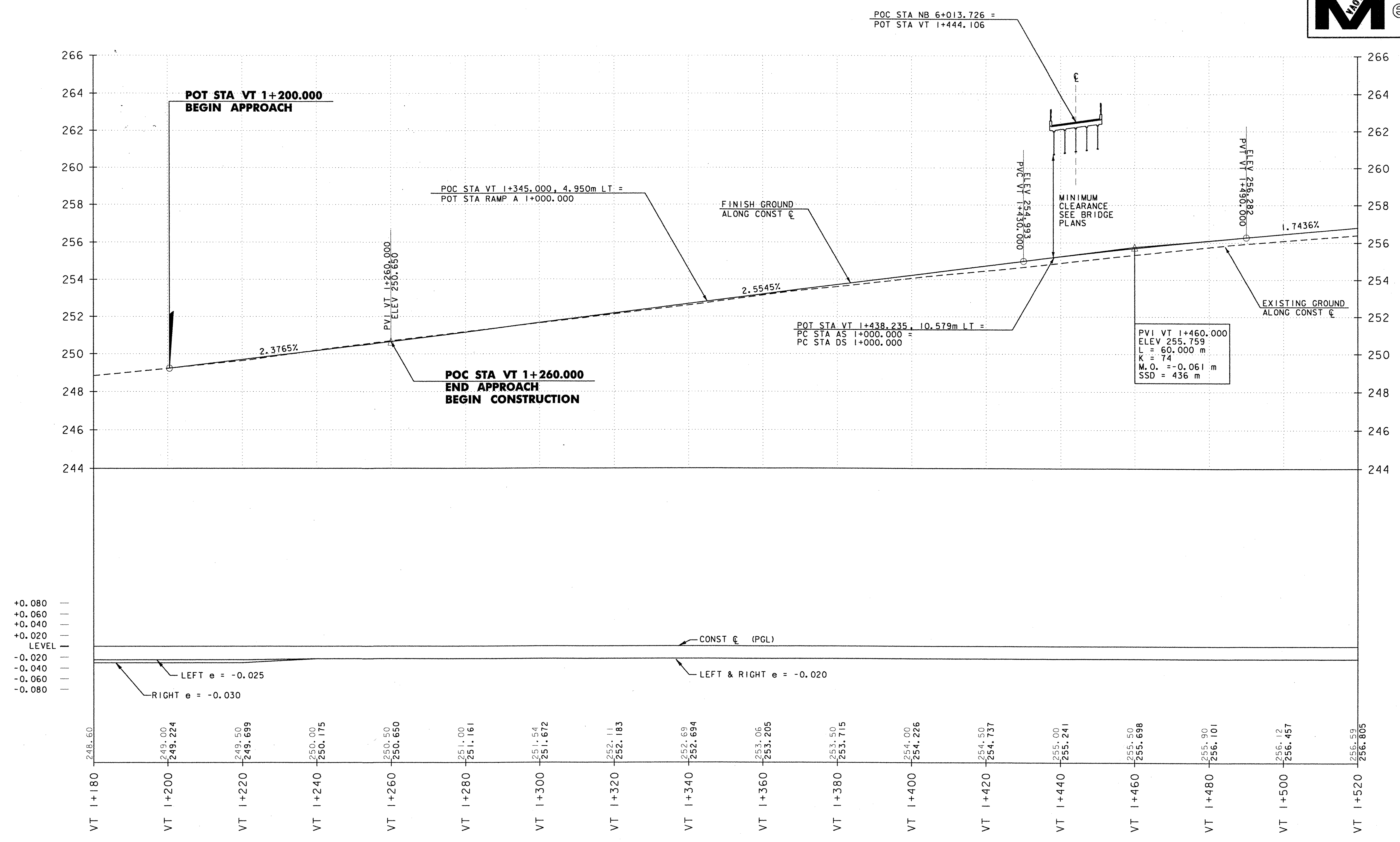

LEVEL
 +0.080
 +0.060
 +0.040
 +0.020
 -0.020
 -0.040
 -0.060
 -0.080

RIGHT e = -0.030
 LEFT e = -0.025
 LEFT & RIGHT e = -0.020

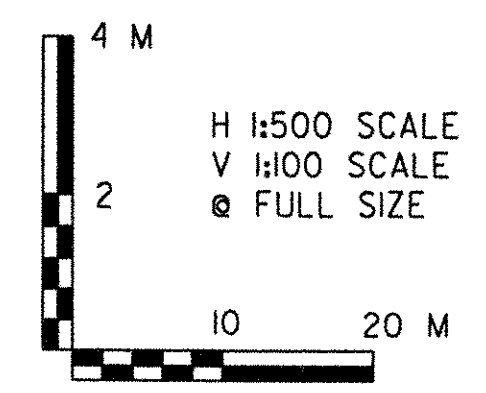

| | |
|--|--|
| VERMONT AGENCY OF TRANSPORTATION | |
| | REVISED |
| | PROJECT NAME: BENNINGTON PROJECT NUMBER: NH FO19-1(5) FILE NAME: ...Profiles\VT9Profile.prf DESIGN SUPERVISOR: GREG EDWARDS DESIGNED BY: MARC FOISY VT ROUTE 9 - PR-56 |
| PLOT DATE: 11/24/2004 DRAWN BY: DUFRESNE-HENRY CHECKED BY: GARY SANTY SHEET 44 OF 112 | |

K:\638020\Bennington\Highway\Profile\Files\VT9Profile.dwg



+0.080
 +0.060
 +0.040
 +0.020
 LEVEL
 -0.020
 -0.040
 -0.060
 -0.080

CONST C (PGL)
 LEFT & RIGHT e = -0.020

| | | | | | | | | | | | | | | | | | | | | | | | | | | | | | | | | | | | | | |
|----------|-------------------|----------|-------------------|----------|-------------------|----------|-------------------|----------|-------------------|----------|-------------------|----------|-------------------|----------|-------------------|----------|-------------------|----------|-------------------|----------|-------------------|----------|-------------------|----------|-------------------|----------|-------------------|----------|-------------------|----------|-------------------|----------|--------|----------|--------|----------|--------|
| VT 1+520 | 256.59 256.805 | VT 1+540 | 257.00 257.154 | VT 1+560 | 257.00 257.503 | VT 1+580 | 257.50 257.861 | VT 1+600 | 258.00 258.289 | VT 1+620 | 258.43 258.797 | VT 1+640 | 259.00 259.373 | VT 1+660 | 259.58 259.960 | VT 1+680 | 260.23 260.519 | VT 1+700 | 260.62 261.023 | VT 1+720 | 261.00 261.472 | VT 1+740 | 261.46 261.866 | VT 1+760 | 261.84 262.232 | VT 1+780 | 262.65 262.998 | VT 1+800 | 264.00 262.964 | VT 1+820 | 264.52 263.330 | VT 1+840 | 265.36 | VT 1+860 | 265.57 | VT 1+880 | 266.43 |
|----------|-------------------|----------|-------------------|----------|-------------------|----------|-------------------|----------|-------------------|----------|-------------------|----------|-------------------|----------|-------------------|----------|-------------------|----------|-------------------|----------|-------------------|----------|-------------------|----------|-------------------|----------|-------------------|----------|-------------------|----------|-------------------|----------|--------|----------|--------|----------|--------|

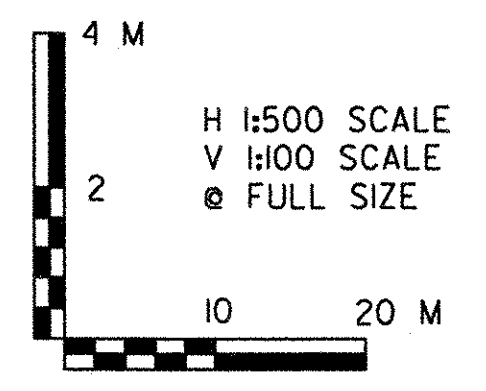

VERMONT AGENCY OF TRANSPORTATION

| | |
|---------------------------------|-----------------------------|
| PROJECT NAME: BENNINGTON | PLOT DATE: 05/27/2003 |
| PROJECT NUMBER: NH F019-1(5) | DRAWN BY: DUFRESNE-HENRY |
| FILE NAME: ...vt19profile.ptf | CHECKED BY: GARY SANTY |
| DESIGN SUPERVISOR: GREG EDWARDS | DESIGNED BY: BJM/MARC FOISY |
| VT ROUTE 9 - PR-57 | |

SHEET 45 OF 112

K:\638020 (benm)\highway\plots\files\profiles\vt19profile.ptf

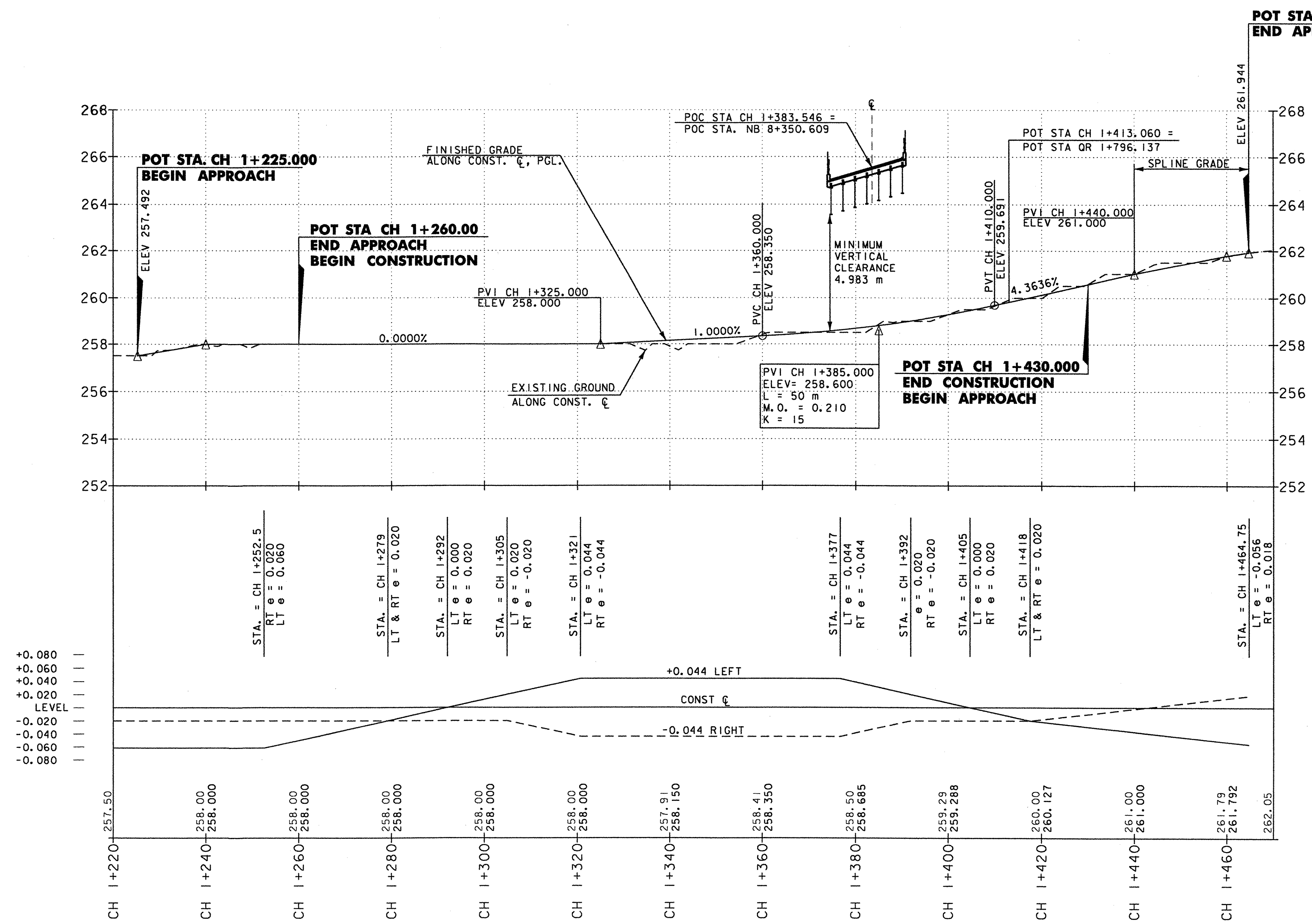

K:\6380020 (benn)\highway\plotfiles\profiles\chapel.dbf

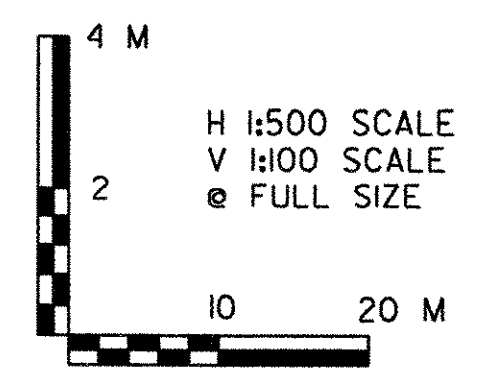

VERMONT AGENCY OF TRANSPORTATION

| | |
|---------------------------------|------------------------------|
| PROJECT NAME: BENNINGTON | PROJECT NUMBER: NH FO19-(K5) |
| FILE NAME: ...\chapel.plt | PLOT DATE: 05/27/2003 |
| DESIGN SUPERVISOR: GREG EDWARDS | DRAWN BY: DUFRESNE-HENRY |
| DESIGNED BY: BJM/MARC FOISY | CHECKED BY: GARY SANTY |
| CHAPEL ROAD - PR-58 | SHEET 46 OF 112 |

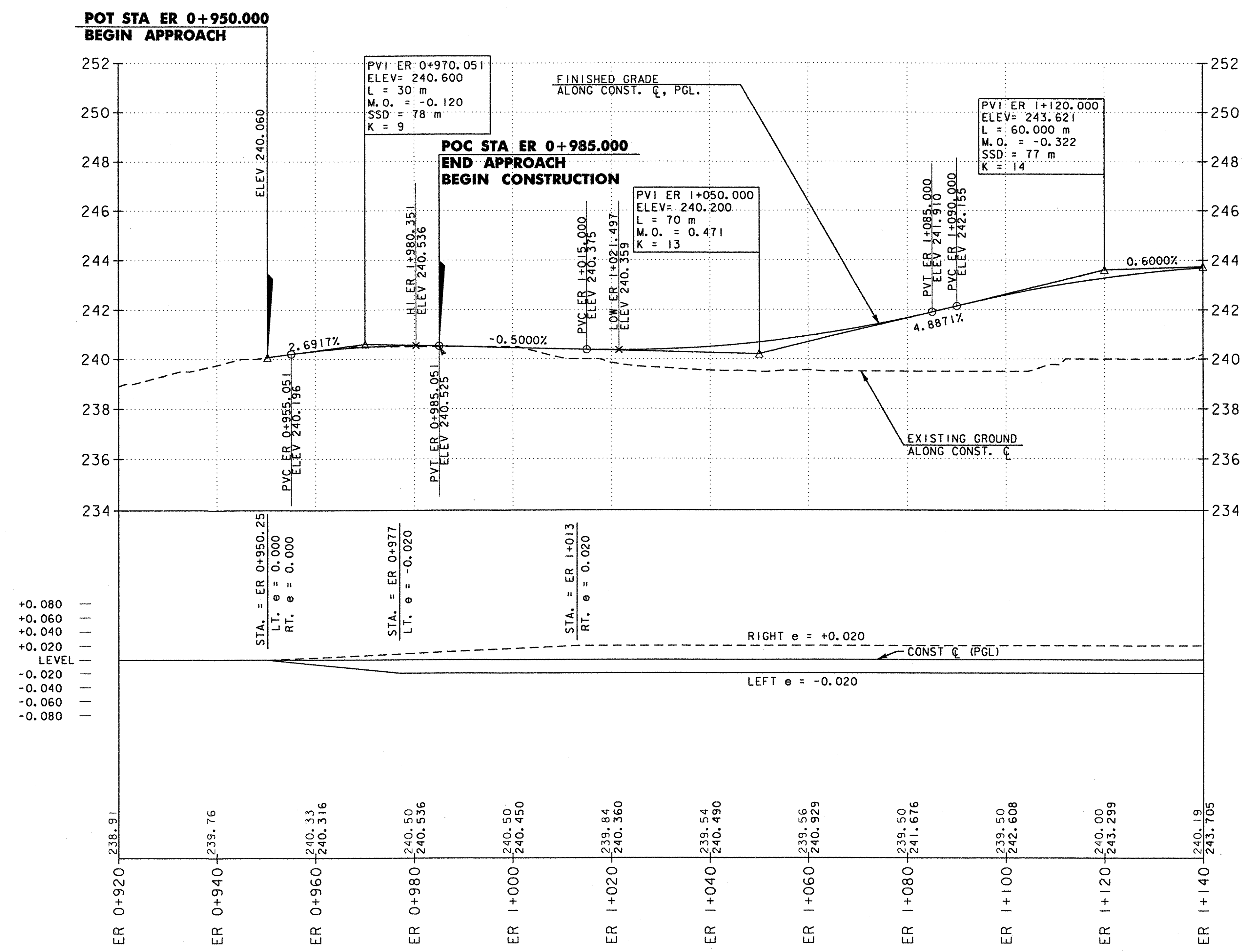

K:\6380020\benm\highway\plot\files\prof\fig\east.prf

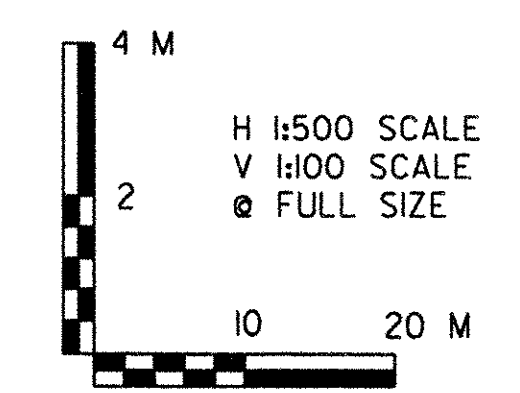

VERMONT AGENCY OF TRANSPORTATION

| | |
|---------------------------------|-----------------------------|
| PROJECT NAME: BENNINGTON | PLOT DATE: 05/27/2003 |
| PROJECT NUMBER: NH F019-1(5) | DRAWN BY: DUFRESNE-HENRY |
| FILE NAME: ...east.prf | CHECKED BY: GARY SANTY |
| DESIGN SUPERVISOR: GREG EDWARDS | DESIGNED BY: BJM/MARC FOISY |
| EAST ROAD - PR-59 | |

SHEET 47 OF 112

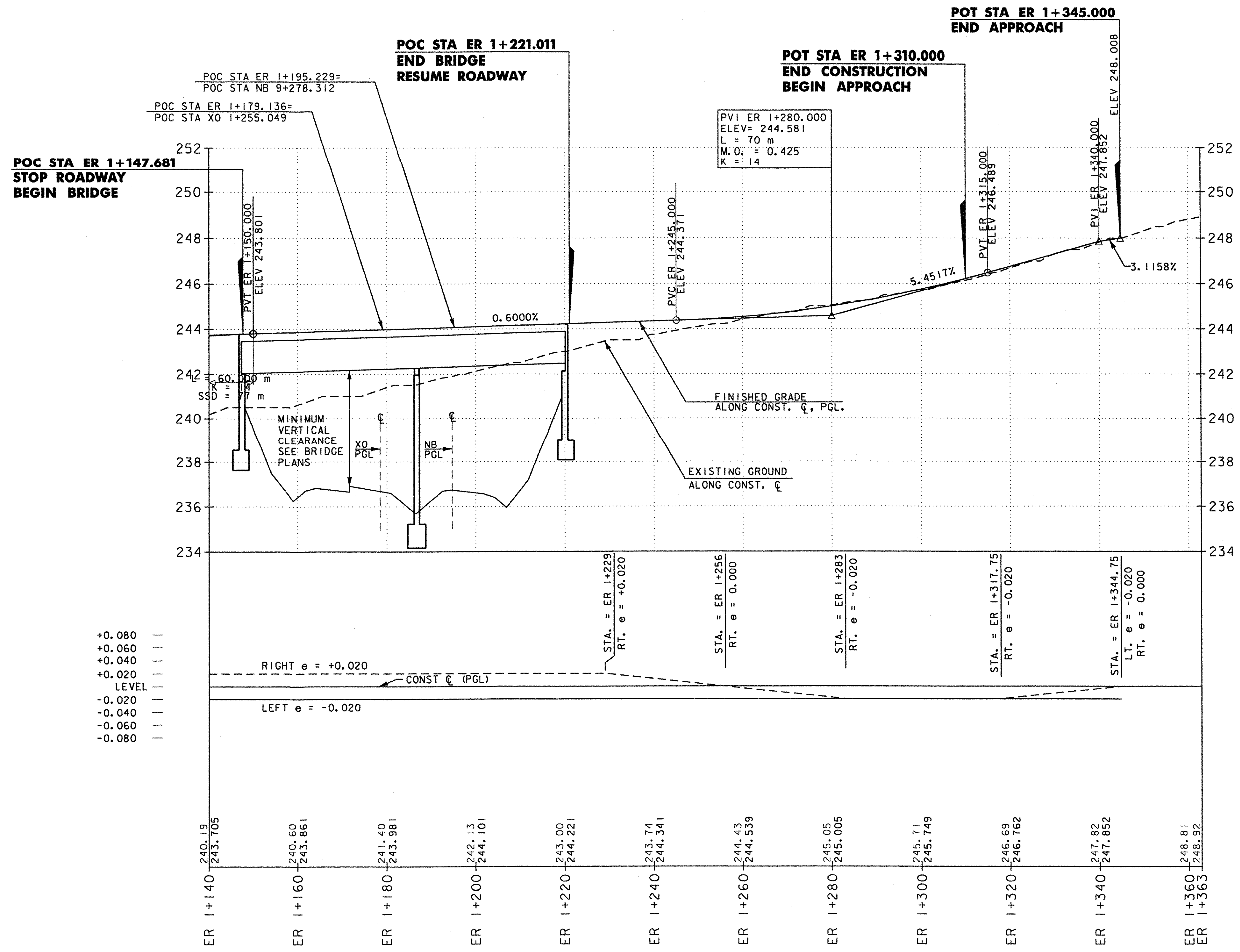

+0.080
+0.060
+0.040
+0.020
LEVEL
-0.020
-0.040
-0.060
-0.080

K:\6380020\benm\highway\profile\er\erfiles\east.prf

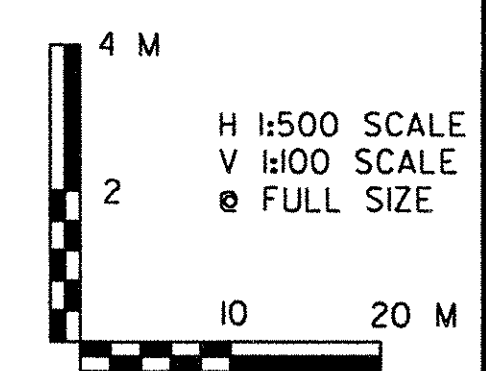

VERMONT AGENCY OF TRANSPORTATION

PROJECT NAME: BENNINGTON
PROJECT NUMBER: NH F019-K(5)

FILE NAME: ...east.prf
DESIGN SUPERVISOR: GREG EDWARDS
DESIGNED BY: BJM/MARC FOISY

PLOT DATE: 05/27/2003
DRAWN BY: DUFRESNE-HENRY
CHECKED BY: GARY SANTY

EAST ROAD - PR-60
SHEET 48 OF 112

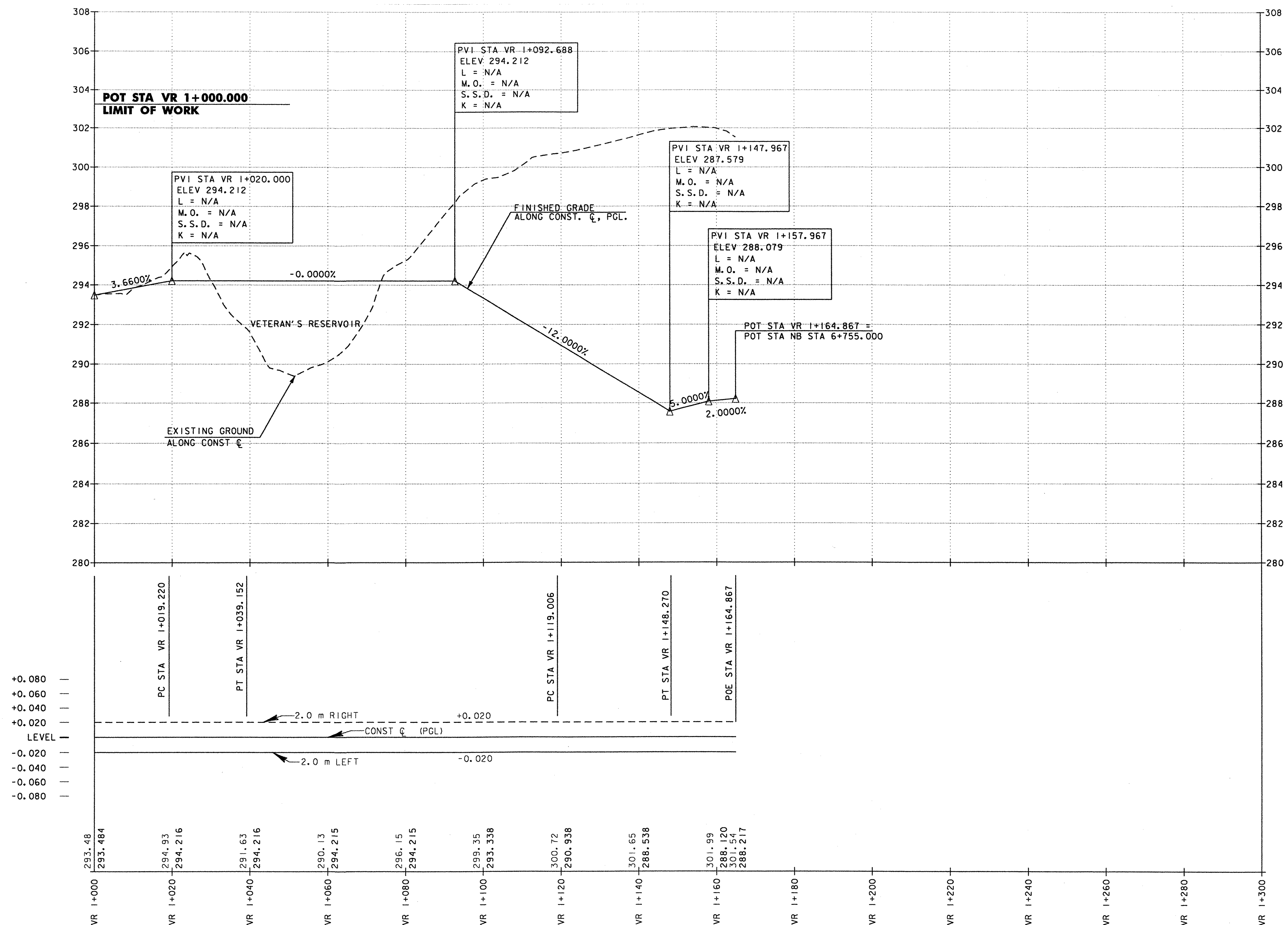

K:\B30020\BennHighway\profiles\vet_res.prf

LEVEL
+0.080
+0.060
+0.040
+0.020
-0.020
-0.040
-0.060
-0.080

VR 1+000 293.48
VR 1+020 294.93
VR 1+040 291.63
VR 1+060 290.13
VR 1+080 296.15
VR 1+100 299.35
VR 1+120 300.72
VR 1+140 301.65
VR 1+160 301.99
VR 1+180
VR 1+200
VR 1+220
VR 1+240
VR 1+260
VR 1+280
VR 1+300

PC STA VR 1+019.220
PT STA VR 1+039.152
PC STA VR 1+119.006
PT STA VR 1+148.270
POE STA VR 1+164.867

2.0 m RIGHT
CONST. C (PGL)
2.0 m LEFT

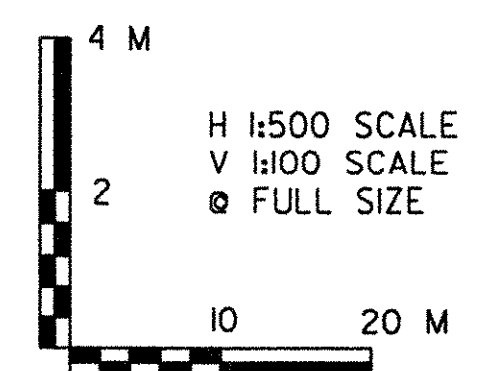

VERMONT AGENCY OF TRANSPORTATION

| | |
|---------------------------------|--------------------------|
| PROJECT NAME: BENNINGTON | PLOT DATE: 05/27/2003 |
| PROJECT NUMBER: NH FO19-(K5) | DRAWN BY: DUFRESNE-HENRY |
| FILE NAME: ...vet_res.prf | CHECKED BY: GARY SANTY |
| DESIGN SUPERVISOR: GREG EDWARDS | SHEET 49 OF 112 |
| DESIGNED BY: BJM/MARC FOISY | |
| VET. RES. - PR-61 | |

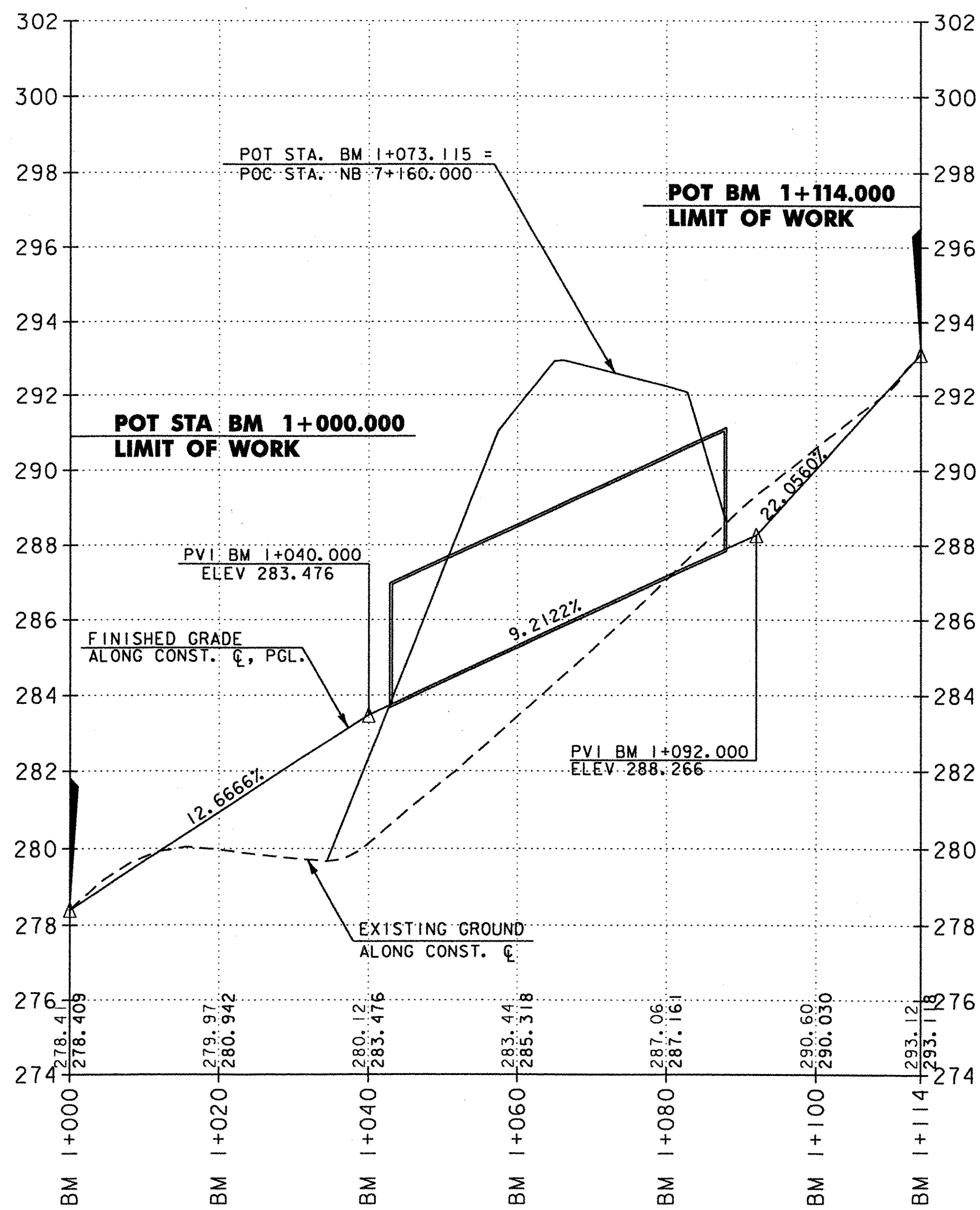

K:\AS160220 (Benn)\Highways\Proj\Files\BaldMtnTrail.PTF

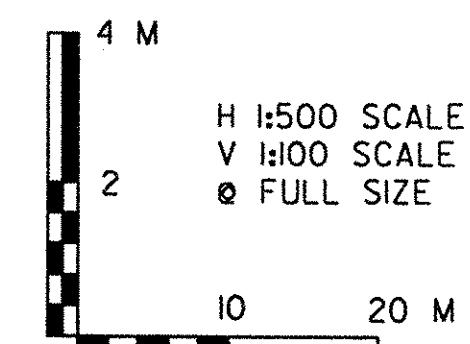

| | |
|---|--------------------------------|
| VERMONT AGENCY OF TRANSPORTATION | |
| | PROJECT NAME: BENNINGTON |
| | PROJECT NUMBER: NH F019-1(5) |
| | FILE NAME: ...\BALDMTTRAIL.PTF |
| DESIGN SUPERVISOR: GREG EDWARDS | PLOT DATE: 05/27/2003 |
| DESIGNED BY: BJM/MARC FOISY | DRAWN BY: DUFRESNE-HENRY |
| BALD MTN. TRAIL - PR-62 | CHECKED BY: GARY SANTY |
| | SHEET 50 OF 112 |

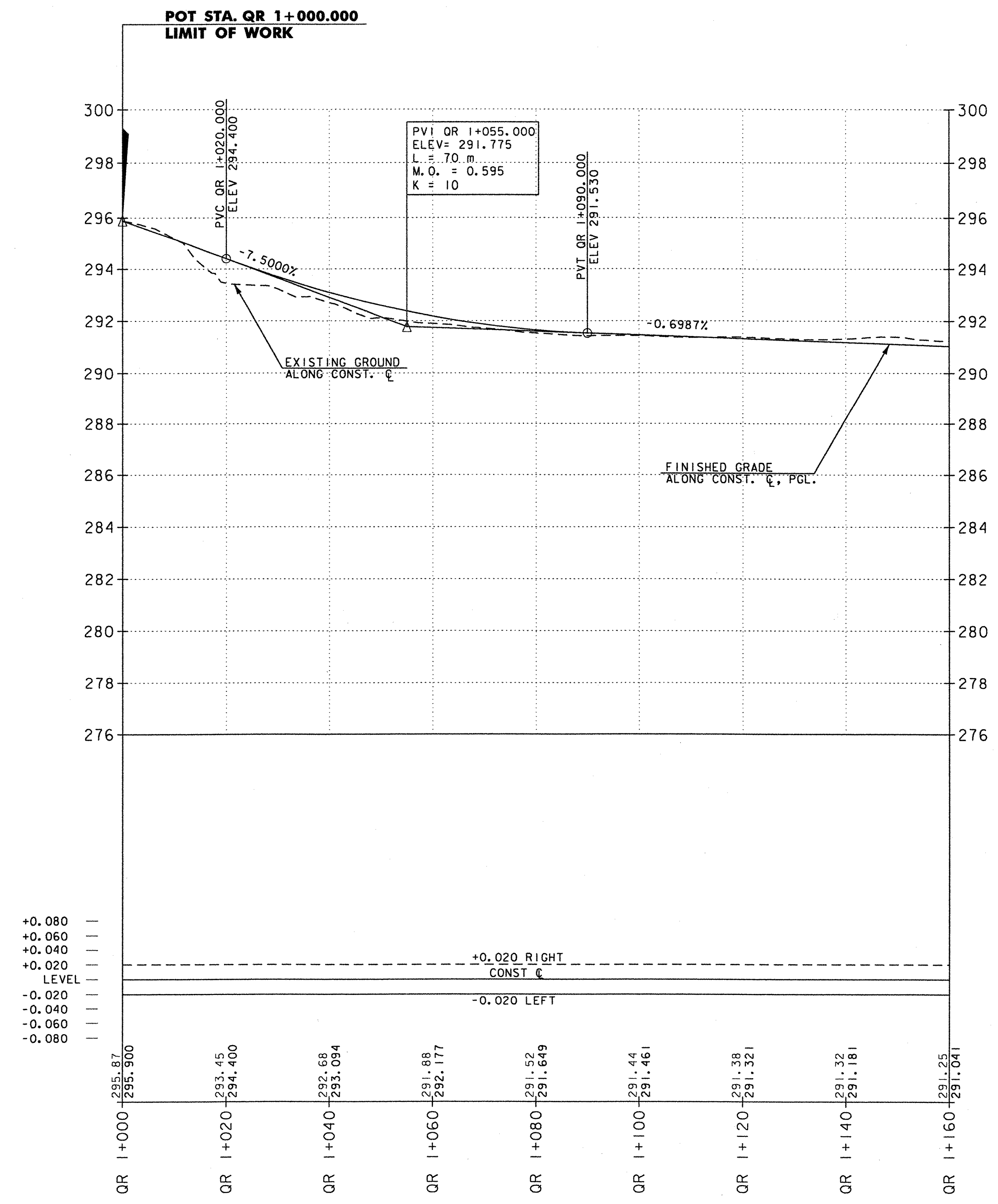

R:\380020 (Benn)\Highway\PlotFiles\Profiles\Quarry.prf

| | |
|---|-----------------------------|
| VERMONT AGENCY OF TRANSPORTATION | |
| | PROJECT NAME: BENNINGTON |
| | PROJECT NUMBER: NH FO19-(5) |
| | FILE NAME: ...Quarry.prf |
| | PLOT DATE: 05/27/2003 |
| DESIGN SUPERVISOR: GREG EDWARDS | DRAWN BY: DUFRESNE-HENRY |
| DESIGNED BY: BJM/MARC FOISY | CHECKED BY: GARY SANTY |
| QUARRY DRIVE - PR-63 | SHEET 51 OF 112 |

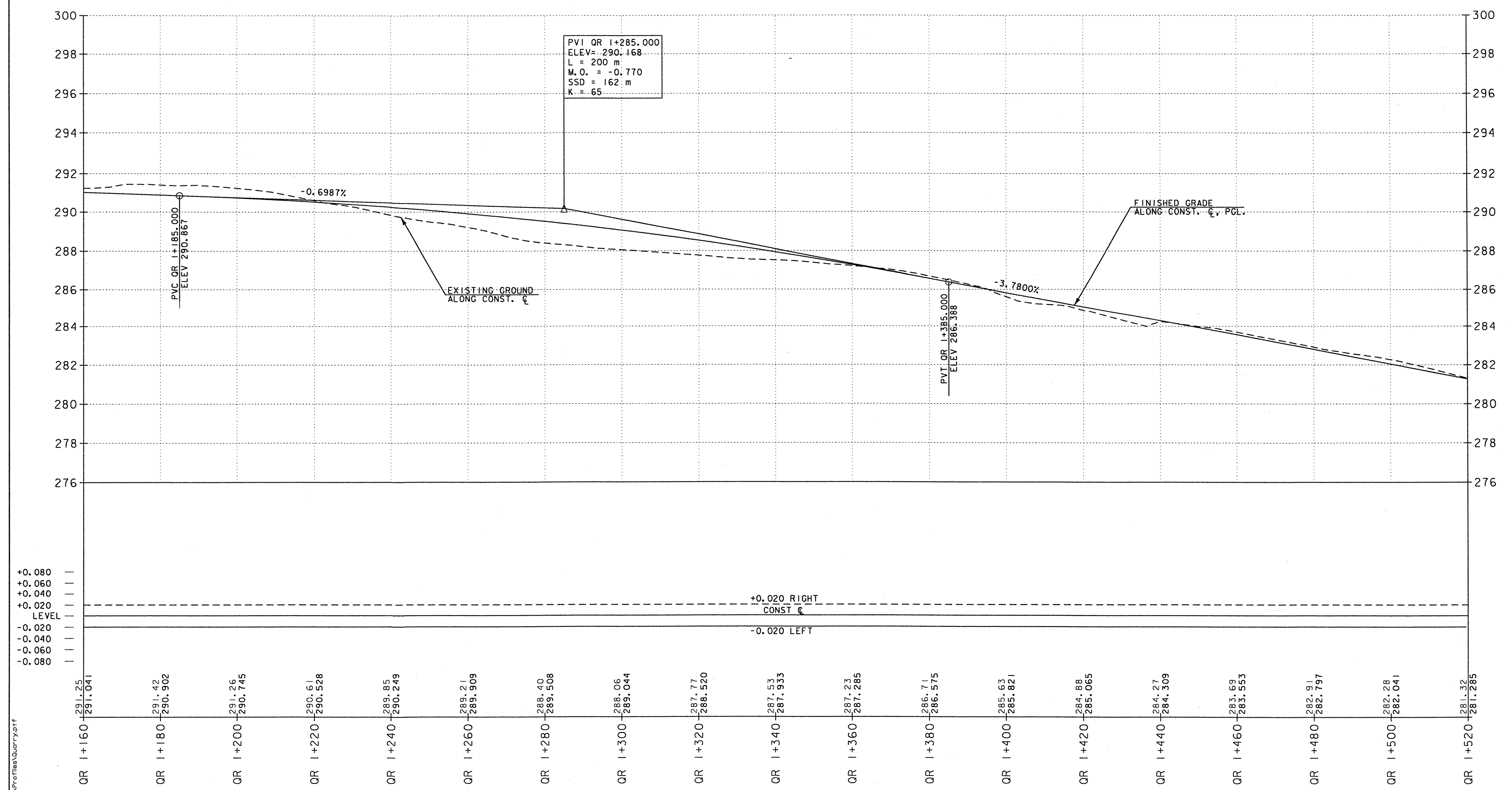

K:\E380020 (Bennington)Highway\PlotFiles\Profiles\Quarry.prf

| | |
|---|------------------------------|
| VERMONT AGENCY OF TRANSPORTATION | |
| | PROJECT NAME: BENNINGTON |
| | PROJECT NUMBER: NH FO19-(K5) |
| | FILE NAME: ...Quarry.prf |
| | PLOT DATE: 05/27/2003 |
| DESIGN SUPERVISOR: GREG EDWARDS | DRAWN BY: DUFRESNE-HENRY |
| DESIGNED BY: BJM/MARC FOISY | CHECKED BY: GARY SANTY |
| QUARRY DRIVE - PR-64 | SHEET 52 OF 112 |

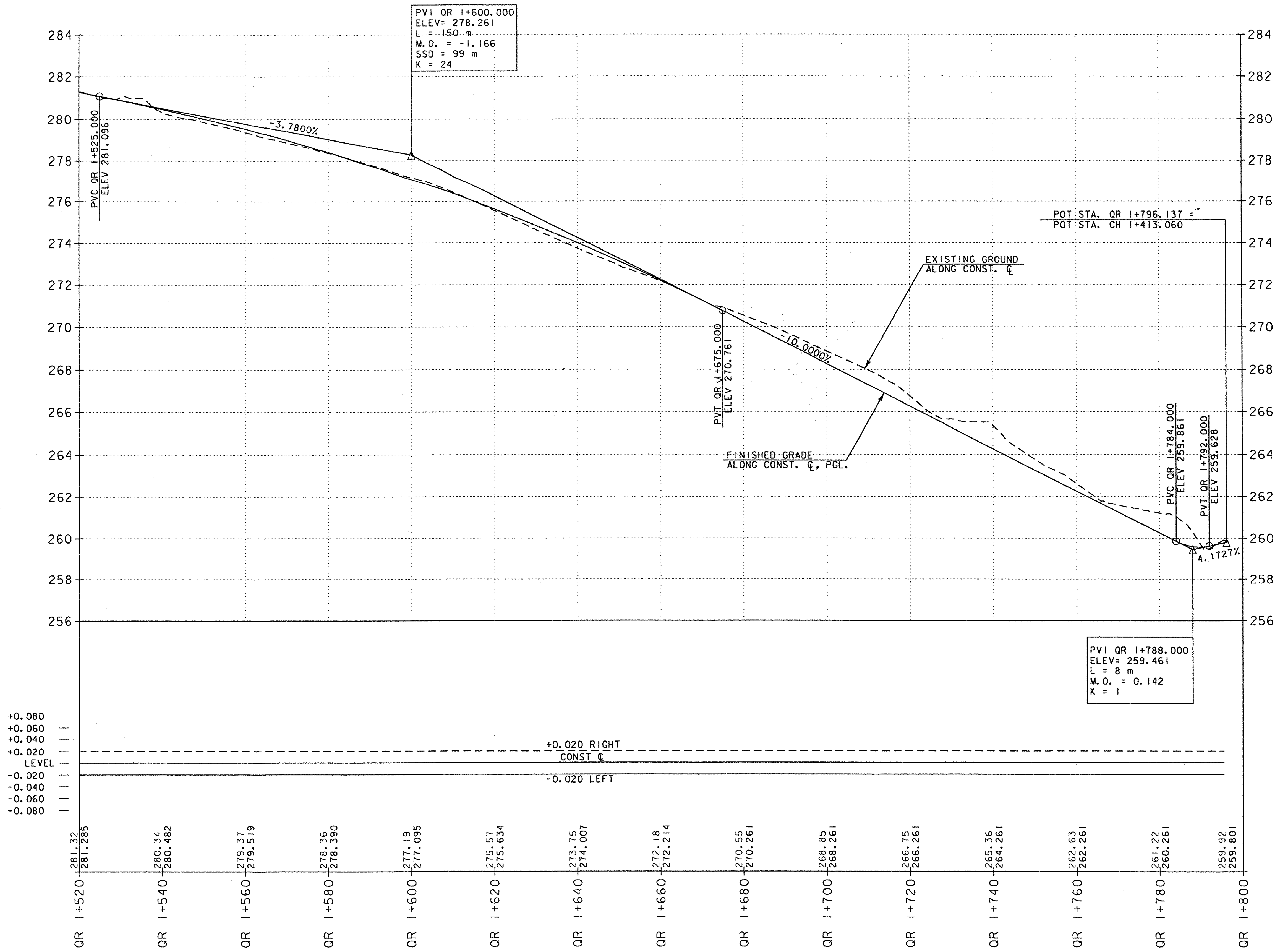

K:\6180020 (Benn)Highway\PlotFiles\ProFiles\Quarry.pbf

VERMONT AGENCY OF TRANSPORTATION



PROJECT NAME: BENNINGTON
 PROJECT NUMBER: NH FO19-(K5)
 FILE NAME: ...Quarry.pbf
 DESIGN SUPERVISOR: GREG EDWARDS
 DESIGNED BY: BJM/MARC FOISY
 PLOT DATE: 05/27/2003
 DRAWN BY: DUFRESNE-HENRY
 CHECKED BY: GARY SANTY
 QUARRY DRIVE - PR-65 SHEET 53 OF 112

RIGHT-OF-WAY PLANS ALPHABETICAL INDEX



| GRANTOR | SHEET NO. | PARCEL NO. |
|---|---|------------|
| A | | |
| APPLEGATE HOUSING LIMITED PARTNERSHIP | 19A | 63 |
| B | | |
| BABCOCK, GEORGE A. & SHIRLEY E. | 27 | 18 |
| BAKER, JOHN M. & DENISE M. | 7 | 46 |
| BARTLETT, WILLIAM J. | 27,28,31 | 43 |
| BENNINGTON COUNTY INDUSTRIAL CORPORATION | 13,14 | 58 |
| BENNINGTON SCHOOL DISTRICT, INC. | 17,22 | 65 |
| BENNINGTON, TOWN OF | 11,11A,12, 13,15,16,17, 22,27-29,30, 32,33 | 66 |
| BIRK, THE WALLY J. REVOCABLE TRUST, WALLY J. BIRK, TRUSTEE | 10,10A | 68 |
| BOUTIN, JESSICA A. | 29 | 29 |
| BUBIER, TODD J. & AMANDA M. | 30 | 38 |
| C | | |
| CANNISTRACI, ANTHONY A. & ANGELA J. | 11,11A | 54 |
| CENTRAL VERMONT PUBLIC SERVICE CORPORATION | 6,6A,7,8,9A, 10,12,13, 27,28 | 21 |
| CHENAILLE, WENDY | 29 | 32 |
| COLE, JANE REALTY, LLC | 7,8,9A,10, 10A,11A | 47 |
| CROSS, PETER K. & PAULA J. | 29 | 35 |
| D | | |
| DEEP, MICHAEL A. TRUSTEE | 6,7,8 | 45 |
| E | | |
| ELLIOTT, WILLIAM P. SR. | 30 | 39 |
| F | | |
| FORREST, SHIRLEY E. ESTATE | 11,11A | 52 |
| G | | |
| GARDNER, GARY | 29 | 32 |
| GARDNER, RICHARD C. JR. | 29 | 32 |
| GARDNER, RICHARD C., SR. & SHIRLEY B. LIFE ESTATE | 29 | 32 |
| GARDNER, SHARON | 29 | 32 |
| GEORGE, GERALD P. | 27 | 20 |
| GOODRICH, STEVEN H. & JANICE E., LESSOR | 28,29 | 28 |
| GREEN MOUNTAIN CLUB, INC. | 8,9,9A | 67 |
| GREENE, FRANCIS E. JR. | 10,11,11A | 50 |
| GREENE, JOSHUA H. | 10,11,11A | 50 |

| GRANTOR | SHEET NO. | PARCEL NO. |
|--|----------------------|------------|
| H | | |
| HADWEN, GEORGE E. TRUST, GEORGE E. HADWEN, TRUSTEE | 11,11A,12, 12A,13 | 55 |
| HALL, JOSEPH H. & MARY I. | 10,10A | 41 |
| HANSON, GAIL | 29 | 32 |
| HARRINGTON, CHRISTOPHER A. & LAURIE L. | 29,30 | 34 |
| HARRINGTON, MICHAEL L. & DEBRA L. | 30 | 37 |
| HARRINGTON, REUBEN A. LIFE ESTATE | 27,28,31 | 43 |
| HARRINGTON, TRACY L. | 27,28,31 | 43 |
| HAWKINS, DEBRA G. | 27 | 20 |
| HOLLAND COMPANY, INC. | 10A,11A | 51 |
| HOOD, THE PATRICIA REVOCABLE TRUST, PATRICIA HOOD & ALAN HOOD CO-TRUSTEES | 15,33 | 60 |
| I | | |
| J | | |
| JELLEY, KEITH R. & FRANCINE M. JEPSON, GERALD A. | 12,13 8,9,9A | 57 48 |
| K | | |
| KIPP, BRENT & RACHEL F. | 27 | 16 |
| L | | |
| LEMAIRE, LAURENCE P. JR. LIVINGSTON, KIM | 19A 29 | 64 32 |
| M | | |
| MAGUIRE, MARY H. & SCOTT R. | 10,10A | 41 |
| MOUNT ANTHONY UNION HIGH SCHOOL DISTRICT NO. 14 | 15 | 62 |
| MOUNTAIN MOZZARELLA, LLC | 33 | 59 |
| MOXLEY, HOWARD J. & TAMMY J. | 29 | 31 |

| GRANTOR | SHEET NO. | PARCEL NO. |
|--|------------|------------|
| N | | |
| NILES, MELODY V. & MARK J. | 28 | 26 |
| NILES, RANDALL C. & RITA C. | 28,32 | 14 |
| NORTH BRANCH REALTY TRUST, MICHAEL A. DEEP, TRUSTEE | 6,7,8 | 45 |
| O | | |
| P | | |
| PALMER, GREGORY R. & JOYCE M. PROUTY, GEORGE E. & JOANNE B. | 29 9,9A | 30 49 |
| Q | | |
| QUALITY PLUMBING & HEATING, INC. LESSEE | 28,29 | 28 |
| R | | |
| S | | |
| SEWARD, LILLIAN A. LIVING TRUST | 28 | 25 |
| SHERMAN, CARL W. & SANDRA L. | 30 | 40 |
| SLEEMAN, RICHARD A. ESTATE | 27,28 | 22 |
| SLEEMAN, ISABELL R. | 28,29,30 | 42 |
| SLEEMAN, ROSEMARY LIVING TRUST | 28 | 24 |
| SLOCUM, ALBERT J. & PATRICIA W. | 12 | 56 |
| SMITH, SCOTT O. ESTATE | 29 | 33 |
| STRICSEK, BARBARA G. | 27 | 20 |
| SWEET, DOUGLAS & LINDA | 28,29 | 27 |

| GRANTOR | SHEET NO. | PARCEL NO. |
|---|----------------------------|------------|
| T | | |
| THE GREEN MOUNTAIN CLUB, INC. | 8,9,9A | 67 |
| THOMAYER, HENRY & CYNTHIA (FORMERLY KNOWN AS CYNTHIA HAMILTON) | 27 | 17 |
| TOWNE, LINDA | 29 | 32 |
| U | | |
| V | | |
| VERIZON | 9,9A,10,11, 11A,12A | 69 |
| VERMONT TRANSCO LLC (VT TRANSCO) | 5A,6,7,8,9,9A, 10,11,12 | 44 |
| W | | |
| WALBRIDGE, J. EDWARD UNKNOWN HEIRS WATSON, CYNTHIA W. | 11,11A 12 | 53 23 |
| WILKINSON, ROY & CAROLYN | 15 | 61 |
| X | | |
| Y | | |
| Z | | |
| ZENO, LINDA L. | 19A | 64 |

PROJECT NAME: **Bennington**
 PROJECT NUMBER: **NH F019-1(5)**
 FILE NAME: **NORTHALPHA** PLOT DATE: **3/28/07**
 PROJECT LEADER: **VSE** DRAWN BY: **GAK**
 DESIGNED BY: **D-H** CHECKED BY: **JDP**
 ALPHABETICAL INDEX SHEET #1 SHEET **54** OF **112**

RIGHT - OF - WAY DETAIL SHEET



TABLE OF PROPERTY ACQUISITION

| PARCEL NO. | PROPERTY OWNER | SHEET NO. | BEGINNING STATION | ENDING STATION | TAKE AREA ± | REMAINDER AREA ± | RIGHT | | | RECORDING DATA | | | | REMARKS | |
|------------|------------------|-------------|-------------------|----------------|-------------|------------------|-------|---------------|--------|----------------|------------|-------------|------|---------|--|
| | | | | | | | TYPE | (T)/(P) | AREA ± | TITLE | DATE | TOWN / CITY | BOOK | | PAGE |
| 1A | STATE OF VERMONT | 4,AA | NB 5+651.03 LT | NB 5+764.19 LT | | | | | | WD | 10/12/2001 | BENNINGTON | 375 | 155 | FORMERLY RACICOT, SELINA M. |
| 1B | | 4,AA | NB 5+750.00 LT | NB 5+772.02 LT | | | | ALL R, T, & I | | | | | | | HWY EASE TH 504 |
| 2A | STATE OF VERMONT | 4,AA | NB 5+681.15 LT | NB 5+750.00 LT | | | | | | WD | 10/29/2003 | BENNINGTON | 402 | 105 | FORMERLY VANDER RIET, DEBORAH K. |
| 2B | | 4,AA | NB 5+739.01 LT | NB 5+757.83 LT | | | | ALL R, T, & I | | | | | | | HWY EASE TH 504 |
| 3 | NOT USED | | | | | | | | | | | | | | |
| 4 | NOT USED | | | | | | | | | | | | | | |
| 5A | STATE OF VERMONT | 4,5,AA | NB 5+746.94 RT | NB 5+811.50 RT | | | | | | WD | 10/2/2001 | BENNINGTON | 375 | 69 | FORMERLY PURDY, ROBERT |
| 5B | | 4,AA | NB 5+739.52 RT | NB 5+756.43 RT | | | | ALL R, T, & I | | | | | | | HWY EASE TH 504 |
| 6A | STATE OF VERMONT | 4,5,AA | NB 5+756.43 RT | NB 5+815.56 LT | | | | | | WD | 9/11/2001 | BENNINGTON | 374 | 142 | FORMERLY GATES, WINFIELD P. SR. & ISABELLE E. |
| 6B | | 4,AA | NB 5+749.02 CL | NB 5+765.69 LT | | | | ALL R, T, & I | | | | | | | HWY EASE TH 504 |
| 7A | STATE OF VERMONT | 4,5,AA | NB 5+765.69 LT | NB 5+822.20 LT | | | | | | WD | 1/10/2002 | BENNINGTON | 378 | 126 | FORMERLY SMITH, TIMOTHY D. |
| 7B | | 4,AA | NB 5+757.83 LT | NB 5+786.34 LT | | | | ALL R, T, & I | | | | | | | HWY EASE TH 504 |
| 8A | STATE OF VERMONT | 4,5,AA | NB 5+786.34 LT | NB 5+917.00 LT | | | | | | WD | 9/18/2001 | BENNINGTON | 374 | 188 | FORMERLY KNAPP, ELLEN G. |
| 8B | | 4,5,AA | NB 5+778.36 LT | NB 5+802.45 LT | | | | ALL R, T, & I | | | | | | | HWY EASE TH 504 |
| 9A | STATE OF VERMONT | 12,EE | NB 8+293.75 RT | NB 8+347.37 RT | 0.082± HA | | | | | WD | 5/11/2004 | BENNINGTON | 408 | 137 | 0.20± A LIMITED ACCESS FORMERLY PARK, JASON E. & TRACY D. |
| 9B | | 12,EE | NB 8+184.64 RT | NB 8+355.67 RT | 4.0± HA | | | | | | | | | | 9.8± A |
| 9C | | 12,EE | NB 8+337.50 RT | NB 8+361.97 RT | 0.046± HA | | | ALL R, T, & I | | | | | | | 0.11± A HWY EASE TH 16 |
| | | | | TOTAL | 4.128± HA | | | | | | | | | | 10.11± A |
| 10A | STATE OF VERMONT | 28,31,AA | VT 1+379.62 RT | VT 1+413.12 RT | 0.17± HA | | | | | WD | 10/21/2003 | BENNINGTON | 402 | 29 | 0.42± A FORMERLY LONG, ROBERT B. & KATHERINE B. |
| 10B | | 28,AA | VT 1+392.62 RT | VT 1+413.74 RT | 0.015± HA | | | ALL R, T, & I | | | | | | | 1614± SF HWY EASE TH 2 / VT RTE 9 |
| | | | | TOTAL | 0.185± HA | | | | | | | | | | 0.46± A |
| 11A | STATE OF VERMONT | 28,31,32,AA | VT 1+405.21 RT | VT 1+471.65 RT | 0.42± HA | | | | | WD | 9/17/2005 | BENNINGTON | 424 | 157 | 1.0± A FORMERLY FENDLER, REED H. |
| 11B | | 28,AA | VT 1+413.12 RT | VT 1+474.15 RT | 0.045± HA | | | ALL R, T, & I | | | | | | | 0.11± A HWY EASE TH 2 / VT RTE 9 |
| | | | | TOTAL | 0.465± HA | | | | | | | | | | 1.11± A |

TABLE OF REVISIONS

| REVISION NO. | SHEET NO. | DESCRIPTION | DATE |
|--------------|--------------------------|---|----------|
| 1 | 56,99 | PARCEL NO. 17 THOMAYER. REVISED TAKE LINE ON ROW SHEET 27 (99 OF 112) AND DETAIL SHEET 2 (56 OF 112) PER C.O. 9453 | 6/5/06 |
| 2 | 57,70 | PARCEL NO. 21 CENTRAL VERMONT PUBLIC SERVICE CORPORATION. REVISED TAKE LINE ON ROW SHEET 6 (70 OF 112) AND DETAIL SHEET 3 (57 OF 112) PER C.O. 9454 | 6/5/06 |
| 3 | 59,102 | PARCEL NO. 40 SHERMAN. CHANGED TAKE TO EASEMENT(P) ROW SHEET 30 (102 OF 112) AND DETAIL SHEET 5 (59 OF 112) PER C.O. 9455 | 6/5/06 |
| 4 | 60,76 | PARCEL NO. 48 JEPSON. REVISED PROPERTY LINE PER PROUTY SURVEY ON ROW SHEET 9 (76 OF 112) AND ADJUSTED CONST(T) AND DIT&DR(P) ON DETAIL SHEET 6 (60 OF 112) PER C.O. 9463 | 7/12/06 |
| 5 | 60,76 | PARCEL NO. 49 PROUTY. REVISED PROPERTY LINE PER PROUTY SURVEY ON ROW SHEET 9 (76 OF 112) AND ADJUSTED CONST(T) AND DIT&DR(P) ON DETAIL SHEET 6 (60 OF 112) PER C.O. 9464 | 7/12/06 |
| 6 | 62,88,94 | PARCEL NO. 65 BENNINGTON SCHOOL DISTRICT, INC. DRAINAGE DESIGN CHANGED ON ROW SHEET 17 (88 OF 112) AND ROW SHEET 22 (94 OF 112). REVISED CONST(T), SR(P), AND ELIMINATED DIT&DR(P), CUL(P), AND LANDSCAPE(T) ON DETAIL SHEET 8 (62 OF 112) PER C.O. 9469 | 7/12/06 |
| 7 | 54,57,69,100,104 | PARCEL NO. 26 NILES. OWNERS ARE MELODY V. NILES & MARK J. NILES. CHANGE OF NAME ISSUED BY BENNINGTON PROBATE COURT DATED 1/23/02. REVISED NAME ON ROW SHEET 8-A (69 OF 112), ROW SHEET 28 (100 OF 112), ROW SHEET 32 (104 OF 112), ALPHABETICAL INDEX #1 (54 OF 112) AND DETAIL SHEET 3 (57 OF 112) PER C.O. 9470 | 07/26/06 |
| 8 | 62,86 | PARCEL NO. 60 HOOD. REVISED LOCATION OF DRIVE AND DRIVE CULVERT ON ROW SHEET 15 (86 OF 112) AND REVISED STATIONS OF DRIVE(T) AND CUL(T) ON DETAIL SHEET 8 (62 OF 112) PER C.O. 9483 | 1/17/07 |
| 9 | 54,59,69,78,80,82,84,106 | PARCEL NO. 44 VT TRANSCO LLC. NAME CHANGED FROM VERMONT ELECTRIC POWER COMPANY, INC. (VELCO) TO VERMONT TRANSCO LLC (VT TRANSCO). NAME CHANGED ON ALPHABETICAL INDEX #1 (54 OF 112), DETAIL SHEET 5 (59 OF 112), ROW SHEETS 5A-10 (69-78 OF 112), ROW SHEET 11 (80 OF 112), ROW SHEET 12 (82 OF 112), ROW SHEET 13 (84 OF 112), AND ROW SHEET AA (106 OF 112) PER C.O. 9487 | 3/8/07 |
| 10 | 54,56,99,103,106 | PARCEL NO. 16 KIPP. NAME CHANGED FROM MAXFIELD, GARTH & SARAH TO KIPP, BRENT & RACHEL ON ALPHABETICAL INDEX #1 (54 OF 112), DETAIL SHEET 2 (56 OF 112), ROW SHEET 27 (99 OF 112), ROW SHEET 31 (103 OF 112) AND ROW SHEET AA (106 OF 112) PER C.O. 9488 | 3/12/07 |
| 11 | 54,56,99,106 | PARCEL NO. 17 THOMAYER. NAME CHANGED FROM THOMAYER, HENRY & HAMILTON, CYNTHIA TO THOMAYER, HENRY & CYNTHIA (FORMERLY KNOWN AS CYNTHIA HAMILTON) ON ALPHABETICAL INDEX #1 (54 OF 112), DETAIL SHEET 2 (56 OF 112), ROW SHEET 27 (99 OF 112) AND ROW SHEET AA (106 OF 112) PER C.O. 9489 | 3/12/07 |
| 12 | 54,57,99,100 | PARCEL NO. 22 SLEEMAN. NAME CHANGED FROM SLEEMAN, RICHARD TO SLEEMAN, RICHARD A. ESTATE ON ALPHABETICAL INDEX #1(54 OF 112), DETAIL SHEET 3 (57 OF 112), ROW SHEET 27 (99 OF 112) AND ROW SHEET 28 (100 OF 112) PER C.O. 9490 | 3/12/07 |
| 13 | 54,57,82,83,109,110 | PARCEL NO. 23 WATSON. NAME CHANGED FROM WATSON, RALPH E. & CYNTHIA W. TO WATSON, CYNTHIA W. ON ALPHABETICAL INDEX #1 (54 OF 112), DETAIL SHEET 3 (57 OF 112), ROW SHEET 12 (82 OF 112), ROW SHEET 12A (83 OF 112), ROW SHEET DD (109 OF 112), AND ROW SHEET EE (110 OF 112) PER C.O. 9491 | 3/12/07 |
| 14 | 54,59,100,101,102 | PARCEL NO. 42 SLEEMAN. NAME CHANGED FROM SLEEMAN, RICHARD A. & ISABELL R. TO SLEEMAN, ISABELL R. ON ALPHABETICAL INDEX #1 (54 OF 112), DETAIL SHEET 5 (59 OF 112), ROW SHEET 28 (100 OF 112), ROW SHEET 29 (101 OF 112) AND ROW SHEET 30 (102 OF 112) PER C.O. 9492 | 3/12/07 |
| 15 | 59 | PARCEL NO. 44 VERMONT TRANSCO LLC. REMOVED "BY OPTION ONLY" - ALL R, T, & I TO UTILITY EASEMENT AT NB 8+174.51 LT TO NB 8+297.6 LT ON DETAIL SHEET 5 (59 OF 112) PER C.O. 9493 | 3/12/07 |

PLAN LEGEND

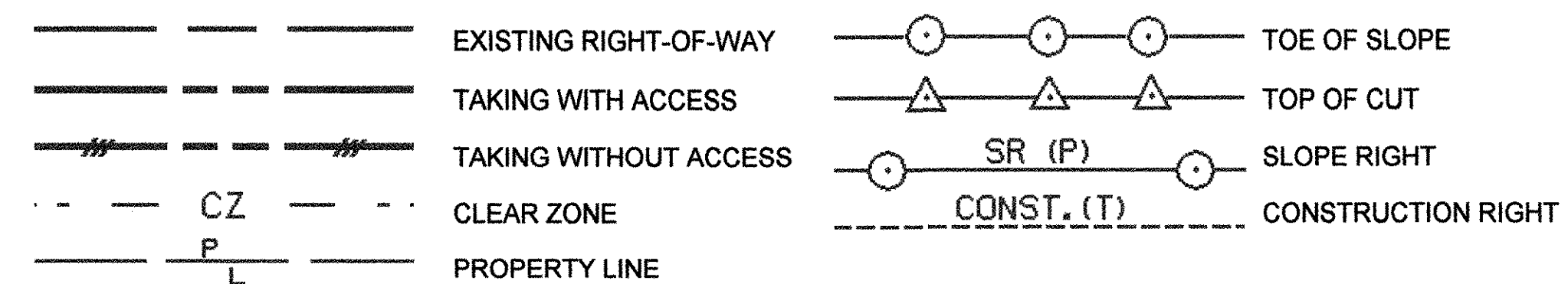

- (P) -PERMANENT
- (T) -TEMPORARY
- DR. -DRAINAGE RIGHT
- DIT. -DITCHING RIGHT
- CH. -CHANNEL RIGHT
- DRIVE -DRIVE RIGHT
- CUL. -CULVERT RIGHT
- C&T -CLEARING & TRIMMING RIGHT
- SR -SLOPE RIGHT
- UE -UTILITY EASEMENT

APPROVED: ROGER P. DUMAS DATE: 12-07-05
CHIEF, PLANS & TITLES

| | | |
|------------------------|---------------------|-------------------------------|
| PROJECT NAME: | Bennington | |
| PROJECT NUMBER: | NH F019-1(5) | |
| FILE NAME: | NORTH.XLS | PLOT DATE: 4/9/07 |
| PROJECT LEADER: | VSE | DRAWN BY: GAK |
| DESIGNED BY: | D-H | CHECKED BY: JDP |
| R.O.W. DETAIL SHEET #1 | | SHEET 55 OF 112 |

RIGHT - OF - WAY DETAIL SHEET



TABLE OF PROPERTY ACQUISITION

| PARCEL NO. | PROPERTY OWNER | SHEET NO. | BEGINNING STATION | ENDING STATION | TAKE AREA ± | REMAINDER AREA ± | RIGHT | | | RECORDING DATA | | | | REMARKS | |
|------------|--|-----------|-------------------|----------------|-------------|------------------|--------------------|---------|--------|----------------|------------|-------------|------|---------|---|
| | | | | | | | TYPE | (T)/(P) | AREA ± | TITLE | DATE | TOWN / CITY | BOOK | | PAGE |
| 12A | STATE OF VERMONT | 32,AA | VT 1+441.72 RT | VT 1+487.62 RT | 0.17± HA | | | | | WD | 8/28/2001 | BENNINGTON | 374 | 62 | 0.42± A FORMERLY PINSKER, RUTH |
| 12B | | 32,AA | VT 1+480.21 RT | VT 1+487.62 RT | 0.016± HA | | ALL R, T, & I | | | | | | | | 1722± SF HWY EASE TH 506 |
| | | | | | TOTAL | 0.186± HA | | | | | | | | | 0.46± A |
| 13A | STATE OF VERMONT | 28,32,AA | VT 1+456.65 RT | VT 1+497.82 RT | 0.14± HA | | | | | WD | 6/9/2005 | BENNINGTON | 421 | 58 | 0.35± A FORMERLY STEWART, JOHN S. |
| 13B | | 28,AA | VT 1+471.65 RT | VT 1+498.67 RT | 0.019± HA | | ALL R, T, & I | | | | | | | | 2045± SF HWY EASE TH 2 / VT RTE 9 |
| | | | | | TOTAL | 0.159± HA | | | | | | | | | 0.39± A |
| 14A | NILES, RANDALL C. & RITA C. | 28,AA | VT 1+497.28 RT | VT 1+517.45 RT | 71± SM | | | | | WD | 5/8/2007 | BENNINGTON | 443 | 117 | 764± SF REGRADE, SEED & MULCH EX GRAV DRIVE |
| | | 28,32 | VT 1+499.6 RT | NB 5+914.5 RT | | | REMOVE DRIVE | T | | | | | | | 3.6 m BIT |
| | | 28 | VT 1+502.5 RT | VT 1+517.45 RT | | | REMOVE & RESET | T | | | | | | | CHAINLINK FENCE |
| | | 28 | VT 1+497.8 RT | VT 1+517.20 RT | | | DISCON & RECON | T | | | | | | | WATER & SEWER SERVICES |
| | | 28 | VT 1+497.3 RT | VT 1+517.2 RT | | | LANDSCAPE | T | | | | | | | |
| 14B | | 28,AA | VT 1+497.82 RT | VT 1+518.24 RT | 0.015± HA | | ALL R, T, & I | | | | | | | | 1614± SF HWY EASE TH 2 / VT RTE 9 |
| | | | | | TOTAL | 0.022± HA | | | | | | | | | 2378± SF |
| 15A | STATE OF VERMONT | 27,31,AA | VT 1+328.67 RT | VT 1+368.76 RT | 0.18± HA | | | | | WD | 1/15/2002 | BENNINGTON | 378 | 172 | 0.45± A FORMERLY GUERARD, DEBORAH A. & BABCOCK, SHIRLEY F. |
| 15B | | 27,AA | VT 1+346.82 RT | VT 1+369.80 RT | 0.016± HA | | ALL R, T, & I | | | | | | | | 1722± SF HWY EASE TH 2 / VT RTE 9 |
| | | | | | TOTAL | 0.196± HA | | | | | | | | | 0.48± A |
| 16A | KIPP, BRENT & RACHEL | 27,AA | VT 1+289.00 RT | VT 1+346.82 RT | 0.032± HA | | | | | COND | 4/19/2007 | BENNINGTON | 443 | 5 | 3444± SF PROPERTY CORNER MONUMENT |
| | | 27 | VT 1+289.00 RT | VT 1+292.46 RT | | | REMOVE & REPLACE | T | | | | | | | GUY WIRE |
| | | 27 | VT 1+303.1 RT | | | | INSTALL & MAINTAIN | P | | | | | | | 3.6 m BIT |
| | | 27 | VT 1+310.0 RT | VT 1+345.70 RT | | | DRIVE | T | | | | | | | WATER & SEWER SERVICES |
| | | 27 | VT 1+289.00 RT | | | | DISCON & RECON | T | | | | | | | REGRADE, SEED, MULCH EXIST GRAV DR |
| | | 27 | VT 1+342.5 RT | | | | REMOVE | T | | | | | | | |
| | | 27 | VT 1+289.0 RT | VT 1+345.7 RT | | | LANDSCAPE | T | | | | | | | |
| 16B | | 27,AA | VT 1+292.30 RT | VT 1+348.28 LT | 0.040± HA | | ALL R, T, & I | | | | | | | | 4305± SF HWY EASE TH 2 / VT RTE 9 |
| | | | | | TOTAL | 0.072± HA | | | | | | | | | 0.18± A |
| 17A | THOMAYER, HENRY & CYNTHIA (FORMERLY KNOWN AS CYNTHIA HAMILTON) | 27,AA | VT 1+244.09 RT | VT 1+292.30 RT | 0.014± HA | | | | | COND | 4/19/2007 | BENNINGTON | 443 | 5 | 1507± SF 205± SF |
| | | 27 | VT 1+267.5 RT | VT 1+290.35 RT | | | SR | T | 19± SM | | | | | | |
| | | 27 | VT 1+250.0 RT | VT 1+289.0 RT | | | LANDSCAPE | T | | | | | | | PROPERTY CORNER MONUMENT |
| | | 27 | VT 1+289.00 RT | VT 1+292.46 RT | | | REMOVE & REPLACE | T | | | | | | | |
| 17B | | 27,AA | VT 1+224.74 RT | VT 1+296.57 LT | 0.051± HA | | ALL R, T, & I | | | | | | | | 0.13± A HWY EASE TH 2 / VT RTE 9 |
| | | | | | TOTAL | 0.065± HA | | | | | | | | | 0.16± A |
| 18 | BABCOCK, GEORGE A. & SHIRLEY E. | 27 | VT 1+218.0 RT | | | | DRIVE | T | | WD | 10/24/2006 | BENNINGTON | 437 | 142 | 5.6 m GRAVEL |
| | | 27,AA | VT 1+213.74 RT | VT 1+229.72 RT | 83± SM | | ALL R,T,&I | | | | | | | | 893± SF HWY EASE TH 2 / VT RTE 9 |
| | | | | | TOTAL | 83± SM | | | | | | | | | 893± SF |
| 19 | NOT USED | | | | | | | | | | | | | | |
| 20 | STRICSEK, BARBARA G., GEORGE, GERALD P., & HAWKINS, DEBRA G. | 27,AA | VT 1+200.00 LT | VT 1+227.54 LT | 0.019± HA | | ALL R, T, & I | | | COND | 4/19/2007 | BENNINGTON | 443 | 5 | 2045± SF HWY EASE TH 2 / VT RTE.9 |
| | | 27 | VT 1+217.4 LT | VT 1+227.9 LT | | | SR | T | 3± SM | | | | | | 32± SF |
| | | | | | TOTAL | 0.019± HA | | | | | | | | | 2045± SF |

TABLE OF REVISIONS

| REVISION NO. | SHEET NO. | DESCRIPTION | DATE |
|--------------|---------------------------|---|---------|
| 16 | 62, 88, 94, 94A, 112 | PARCEL NO. 65 BENNINGTON SCHOOL DISTRICT, INC. ALL RIGHTS ELIMINATED ON DETAIL SHEET 8 (62 OF 112), ROW SHEET 17 (88 OF 112), ROW SHEET 22 (94 OF 112), ROW SHEET 22A (94A OF 112), AND ROW SHEET GG (112 OF 112) PER C.O. 9484 | 3/22/07 |
| 17 | 57, 69, 70, 100, 101, 106 | PARCEL NO. 21 CENTRAL VERMONT PUBLIC SERVICE CORPORATION. ADDED PARCEL 21G ON DETAIL SHEET 3 (57 OF 112), ROW SHEET 5A (69 OF 112), ROW SHEET 6 (70 OF 112), ROW SHEET 28 (100 OF 112), AND ROW SHEET 29 (101 OF 112). CHANGED "EASEMENT" TO "FACILITIES" ON DETAIL SHEET 3 (57 OF 112). ELIMINATED PARCEL AT NB 8+211.0 LT - NB 8+316.47 LT, 0.20± HA (0.49±A) ON DETAIL SHEET 3 (57 OF 112) PER C.O. 9485 | 4/25/07 |
| 18 | 56-63 | ADDED RECORDING DATA TO DETAIL SHEETS 2-9 (56-63 OF 112) PER C.O. 9500 | 11/2/07 |

PLAN LEGEND

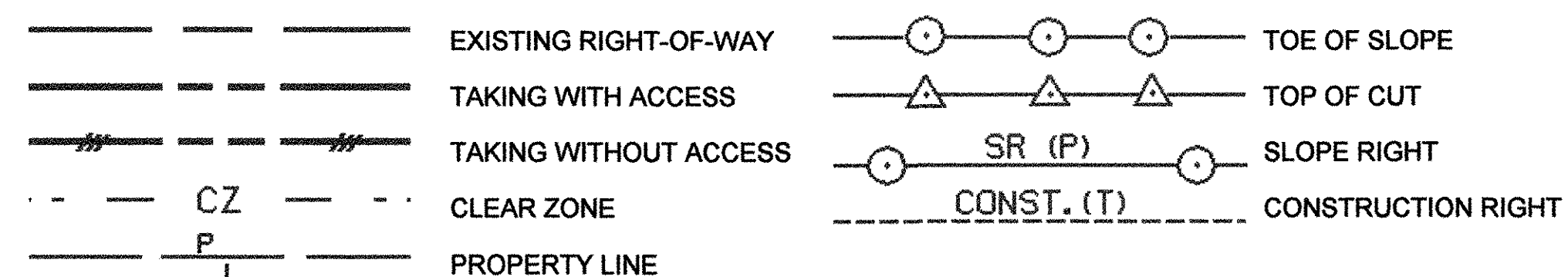

- (P) -PERMANENT
- (T) -TEMPORARY
- DR. -DRAINAGE RIGHT
- DIT. -DITCHING RIGHT
- CH. -CHANNEL RIGHT
- DRIVE -DRIVE RIGHT
- CUL. -CULVERT RIGHT
- C&T -CLEARING & TRIMMING RIGHT
- SR -SLOPE RIGHT
- UE -UTILITY EASEMENT

APPROVED: ROGER P. DUMAS DATE: 12-07-05
CHIEF, PLANS & TITLES

PROJECT NAME: **Bennington**
PROJECT NUMBER: **NH F019-1(5)**
FILE NAME: **NORTH.XLS** PLOT DATE: **11/02/07**
PROJECT LEADER: **VSE** DRAWN BY: **GAK**
DESIGNED BY: **D-H** CHECKED BY: **JDP**
R.O.W. DETAIL SHEET #2 SHEET **56** OF **112**

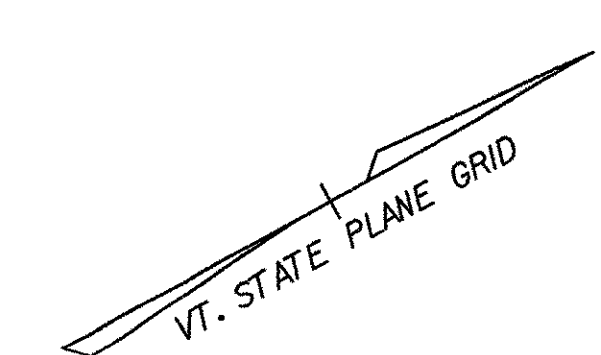

LINES SHOWN ON THIS PLAN AS EXISTING PROPERTY LINES P/L ARE BELIEVED TO BE ACCURATE BUT SHOULD NOT BE RELIED UPON FOR PURPOSES UNRELATED TO THE STATE OF VERMONT'S ACQUISITION OF LAND AND RIGHTS FOR THIS PROJECT.

THIS SHEET TO BE USED FOR RIGHT-OF-WAY INFORMATION ONLY

DATUM
 VERTICAL NAVD 88
 HORIZONTAL NAD 83 (1992)

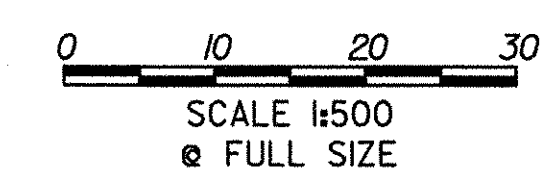

| | | |
|----------------------------------|--|----------------------------------|
| R.O.W. PLAN ROW-1 | PROJECT NAME: BENNINGTON BYPASS | PROJECT NUMBER: NH F019-1(5) |
| | DESIGN FILE NAME: c:\dh\bennington\row | PLOT DATE: 11-02-05 |
| | PROJECT LEADER: JDP | DRAWN BY: MBB CHECKED BY: GAK |
| | | SHEET: 64 OF 112 |

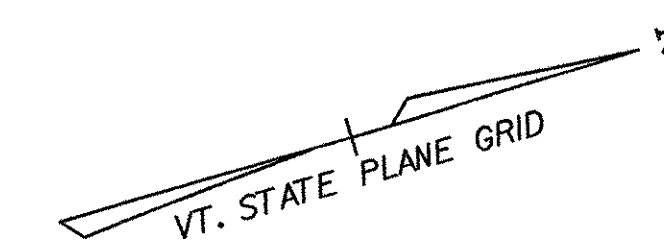

LINES SHOWN ON THIS PLAN AS EXISTING PROPERTY LINES P/L ARE BELIEVED TO BE ACCURATE BUT SHOULD NOT BE RELIED UPON FOR PURPOSES UNRELATED TO THE STATE OF VERMONT'S ACQUISITION OF LAND AND RIGHTS FOR THIS PROJECT.

THIS SHEET TO BE USED FOR RIGHT-OF-WAY INFORMATION ONLY

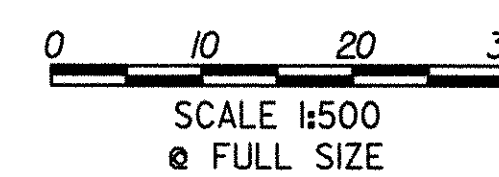

**R.O.W.
PLAN
ROW-2**

| | |
|--|---------------------------------|
| PROJECT NAME: BENNINGTON BYPASS | PROJECT NUMBER: NH FO19-1(5) |
| DESIGN FILE NAME: c:\dh\bennington\row | PLOT DATE: 11-02-05 |
| PROJECT LEADER: JDP | DRAWN BY: MBB |
| | CHECKED BY: GAK |
| SHEET: 65 OF 112 | |

DATUM
VERTICAL NAVD 88
HORIZONTAL NAD 83 (1992)

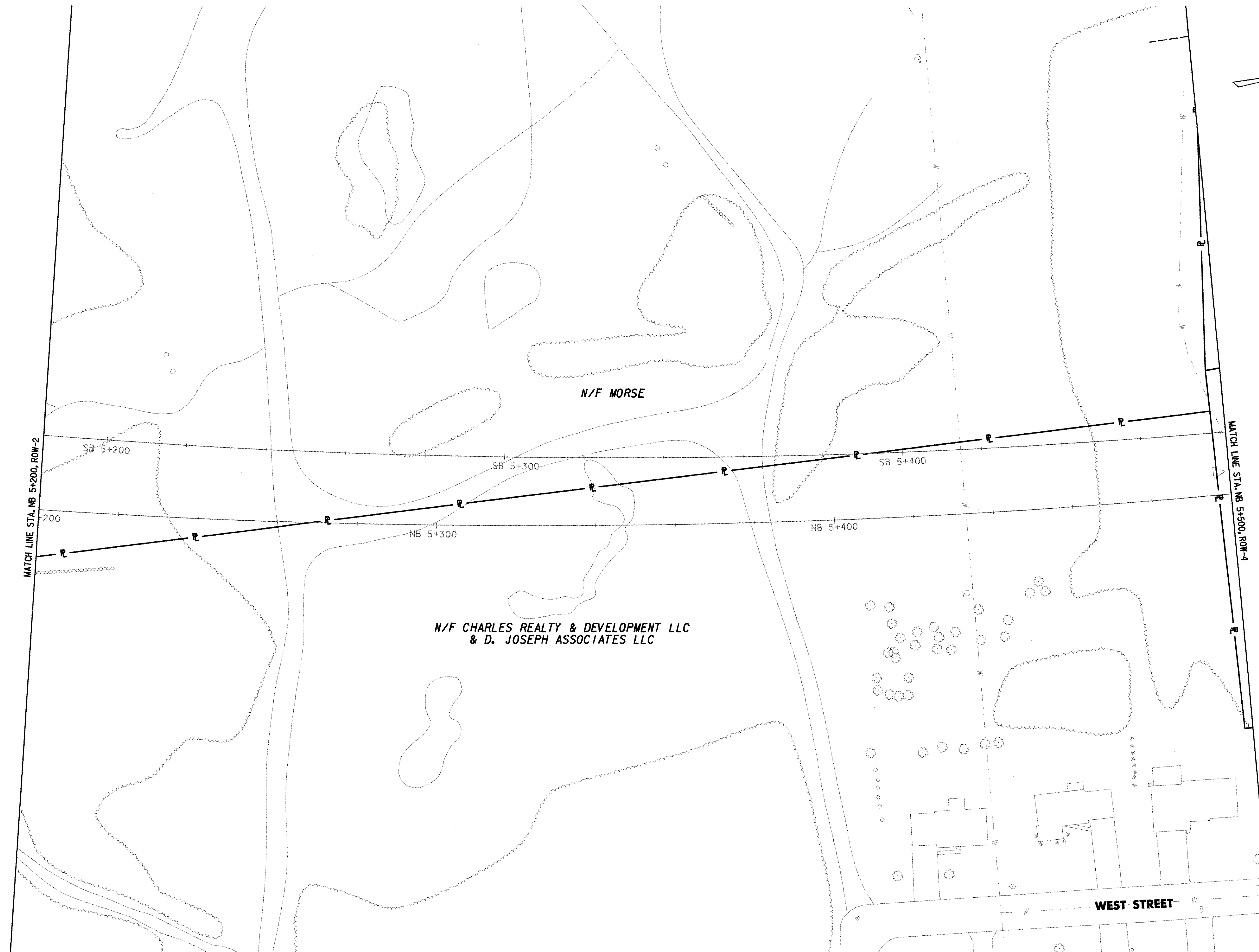

N/F MORSE
N/F CHARLES REALTY & DEVELOPMENT LLC
& D. JOSEPH ASSOCIATES LLC

DATUM
VERTICAL NAVD 88
HORIZONTAL NAD 83 (1992)

LINES SHOWN ON THIS PLAN AS EXISTING PROPERTY LINES P/L ARE BELIEVED TO BE ACCURATE BUT SHOULD NOT BE RELIED UPON FOR PURPOSES UNRELATED TO THE STATE OF VERMONT'S ACQUISITION OF LAND AND RIGHTS FOR THIS PROJECT.

THIS SHEET TO BE USED FOR RIGHT-OF-WAY INFORMATION ONLY

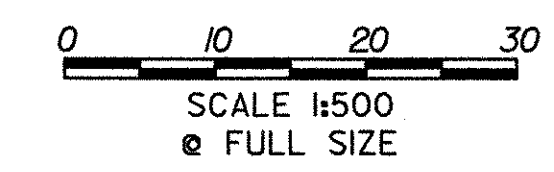

**R.O.W.
PLAN
ROW-3**

| | |
|---|--|
| PROJECT NAME: BENNINGTON BYPASS | PROJECT NUMBER: NH FO19-K(5) |
| DESIGN FILE NAME: c:\dh\bennington\row | PLOT DATE: 11-02-05 |
| PROJECT LEADER: JDP | DRAWN BY: MBB |
| | CHECKED BY: GAK |
| SHEET: 66 OF 112 | |

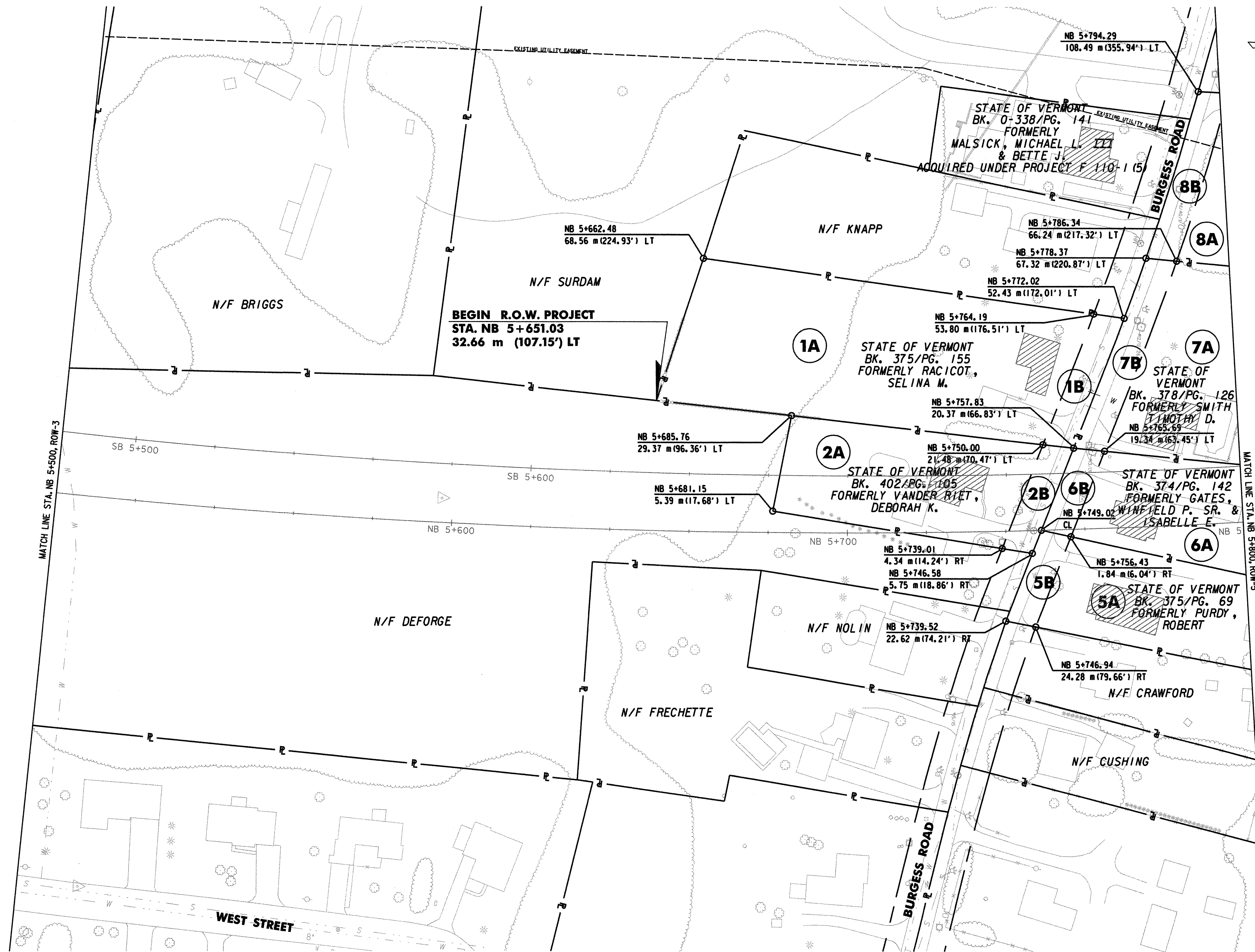

LINES SHOWN ON THIS PLAN AS EXISTING PROPERTY LINES P/L ARE BELIEVED TO BE ACCURATE BUT SHOULD NOT BE RELIED UPON FOR PURPOSES UNRELATED TO THE STATE OF VERMONT'S ACQUISITION OF LAND AND RIGHTS FOR THIS PROJECT.

THIS SHEET TO BE USED FOR RIGHT-OF-WAY INFORMATION ONLY

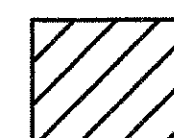
 SIGNIFIES DEMOLITION & REMOVAL OF STRUCTURES AND IMPROVEMENTS

0 10 20 30
SCALE 1:500
@ FULL SIZE

**R.O.W. PLAN
ROW-4**

PROJECT NAME: BENNINGTON BYPASS
DESIGN FILE NAME: c:\dh\bennington\row
PROJECT LEADER: JDP

PROJECT NUMBER: NH F019-1(5)

PLOT DATE: 11-02-05
DRAWN BY: MBB
CHECKED BY: GAK

SHEET: 67 OF 112

DATUM
VERTICAL NAVD 88
HORIZONTAL NAD 83 (1992)

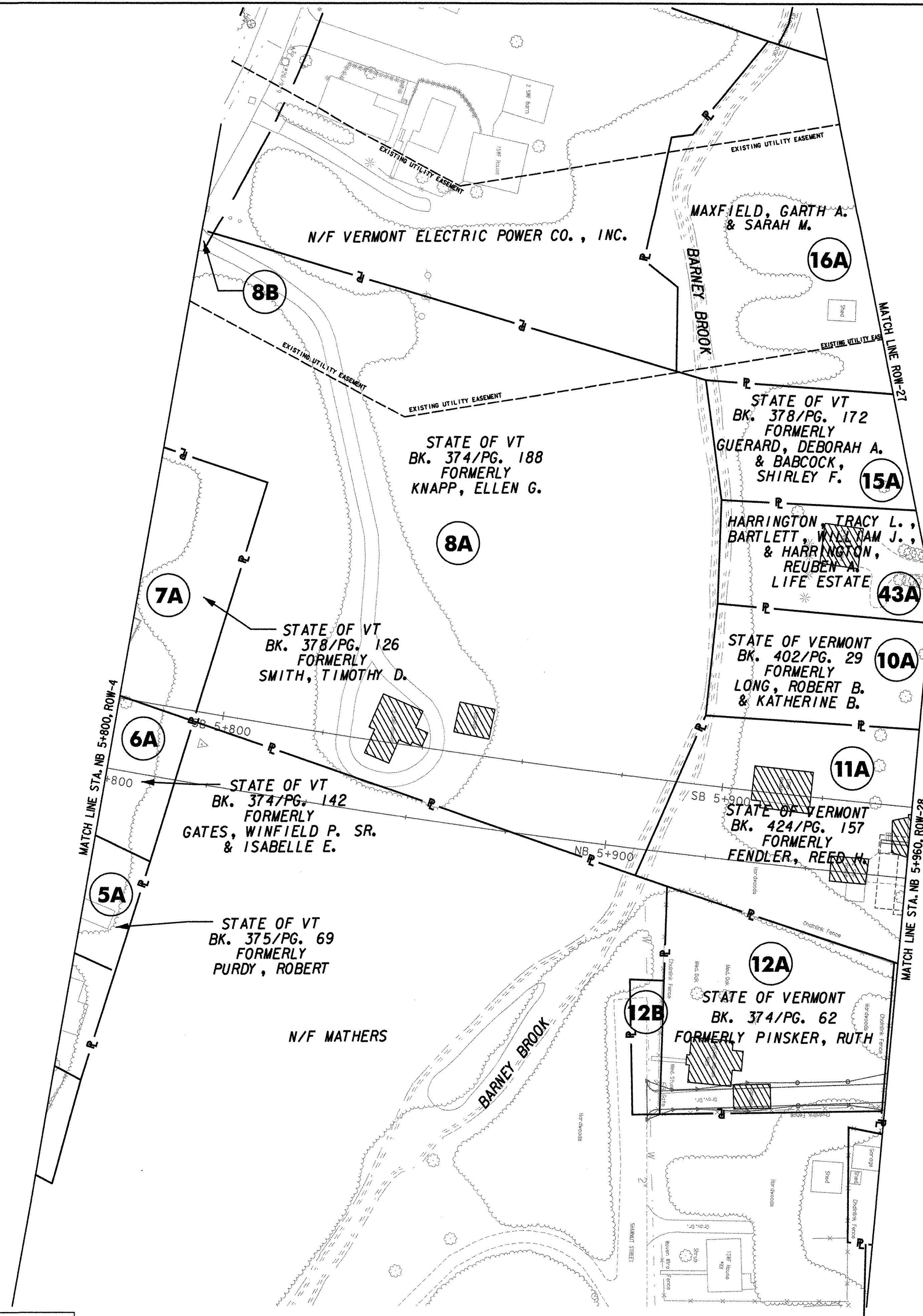
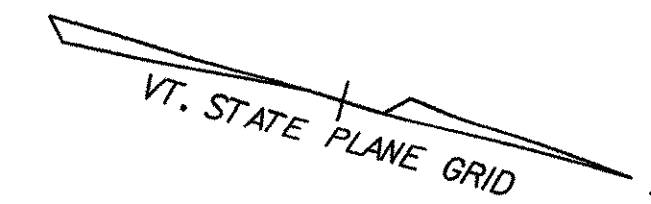

SEE SHEETS ROW-31 AND ROW-32 FOR DETAILED INFORMATION

LINES SHOWN ON THIS PLAN AS EXISTING PROPERTY LINES P/L ARE BELIEVED TO BE ACCURATE BUT SHOULD NOT BE RELIED UPON FOR PURPOSES UNRELATED TO THE STATE OF VERMONT'S ACQUISITION OF LAND AND RIGHTS FOR THIS PROJECT.

THIS SHEET TO BE USED FOR RIGHT-OF-WAY INFORMATION ONLY

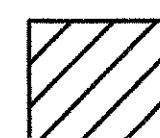

SIGNIFIES DEMOLITION & REMOVAL OF STRUCTURES AND IMPROVEMENTS

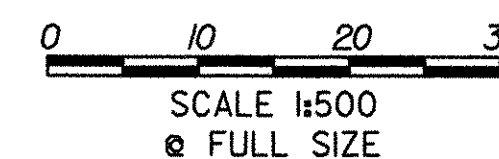

DATUM
 VERTICAL NAVD 88
 HORIZONTAL NAD 83 (1992)

**R.O.W. PLAN
 ROW-5**

PROJECT NAME: BENNINGTON BYPASS
 DESIGN FILE NAME: c:\nh\bennington\row
 PROJECT LEADER: JDP

PROJECT NUMBER: NH FO19-1(5)

PLOT DATE: 1-30-06
 DRAWN BY: MBB
 CHECKED BY: GAK

SHEET: 68 OF 112

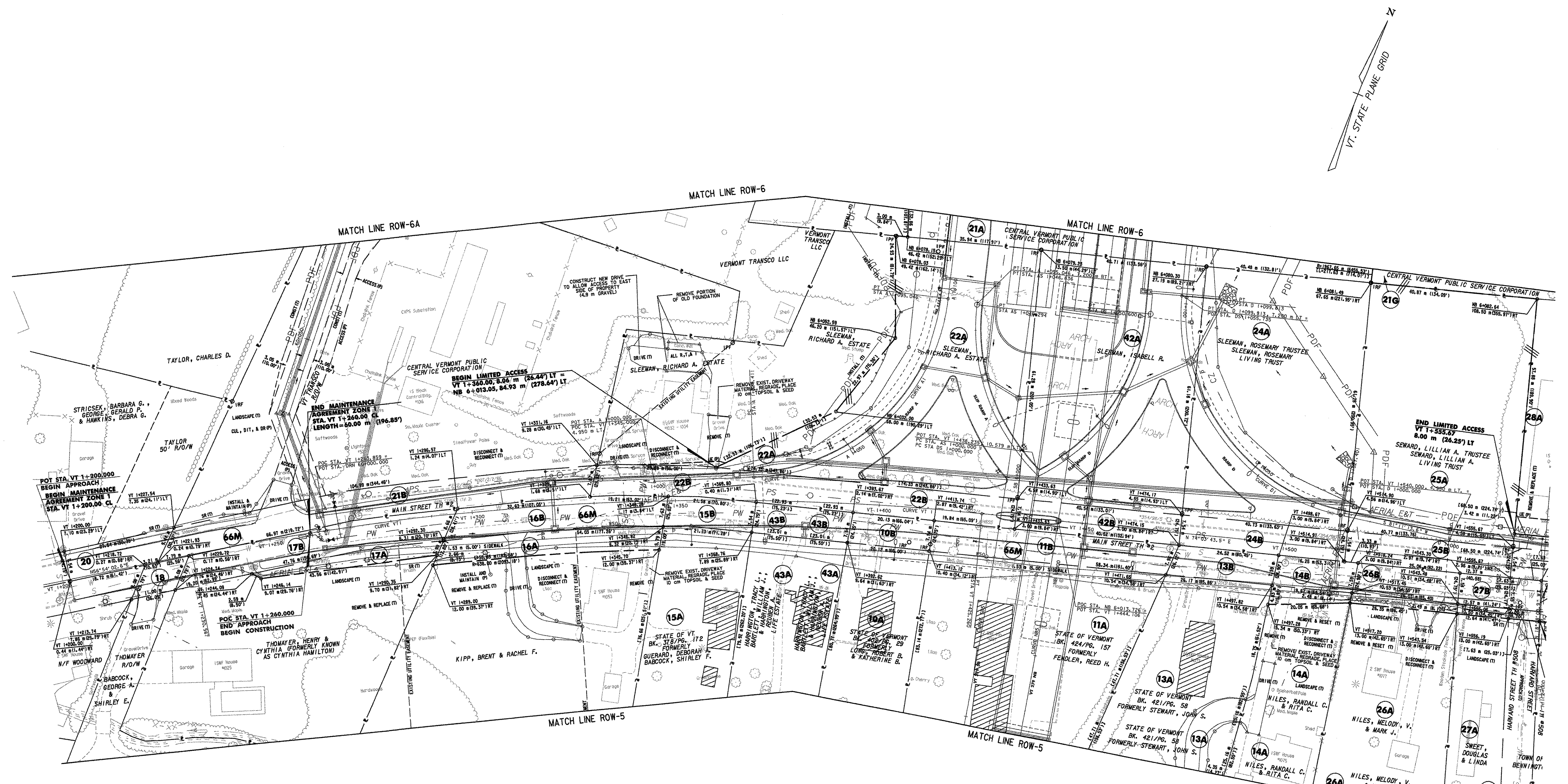

THIS SHEET HAS BEEN DEVELOPED TO PROVIDE AN OVERVIEW FOR THE APPRAISER. FOR DETAILED INFORMATION SEE SHEETS ROW-27 AND ROW-28

DATUM
 VERTICAL NAVD 88
 HORIZONTAL NAD 83 (1992)

LINES SHOWN ON THIS PLAN AS EXISTING PROPERTY LINES P/L ARE BELIEVED TO BE ACCURATE BUT SHOULD NOT BE RELIED UPON FOR PURPOSES UNRELATED TO THE STATE OF VERMONT'S ACQUISITION OF LAND AND RIGHTS FOR THIS PROJECT.

THIS SHEET TO BE USED FOR RIGHT-OF-WAY INFORMATION ONLY

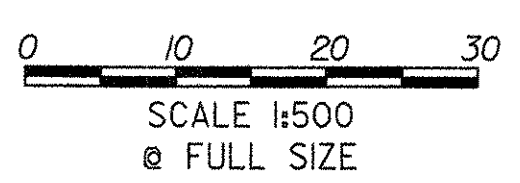

| | | |
|-----------------------------------|--|----------------------------------|
| R.O.W. PLAN ROW-5A | PROJECT NAME: BENNINGTON BYPASS | PROJECT NUMBER: NH FO19-(K5) |
| | DESIGN FILE NAME: c:\nh\bennington\row | PLOT DATE: 4-25-07 |
| | PROJECT LEADER: JDP | DRAWN BY: MBB CHECKED BY: GAK |
| | | SHEET: 69 OF 112 |

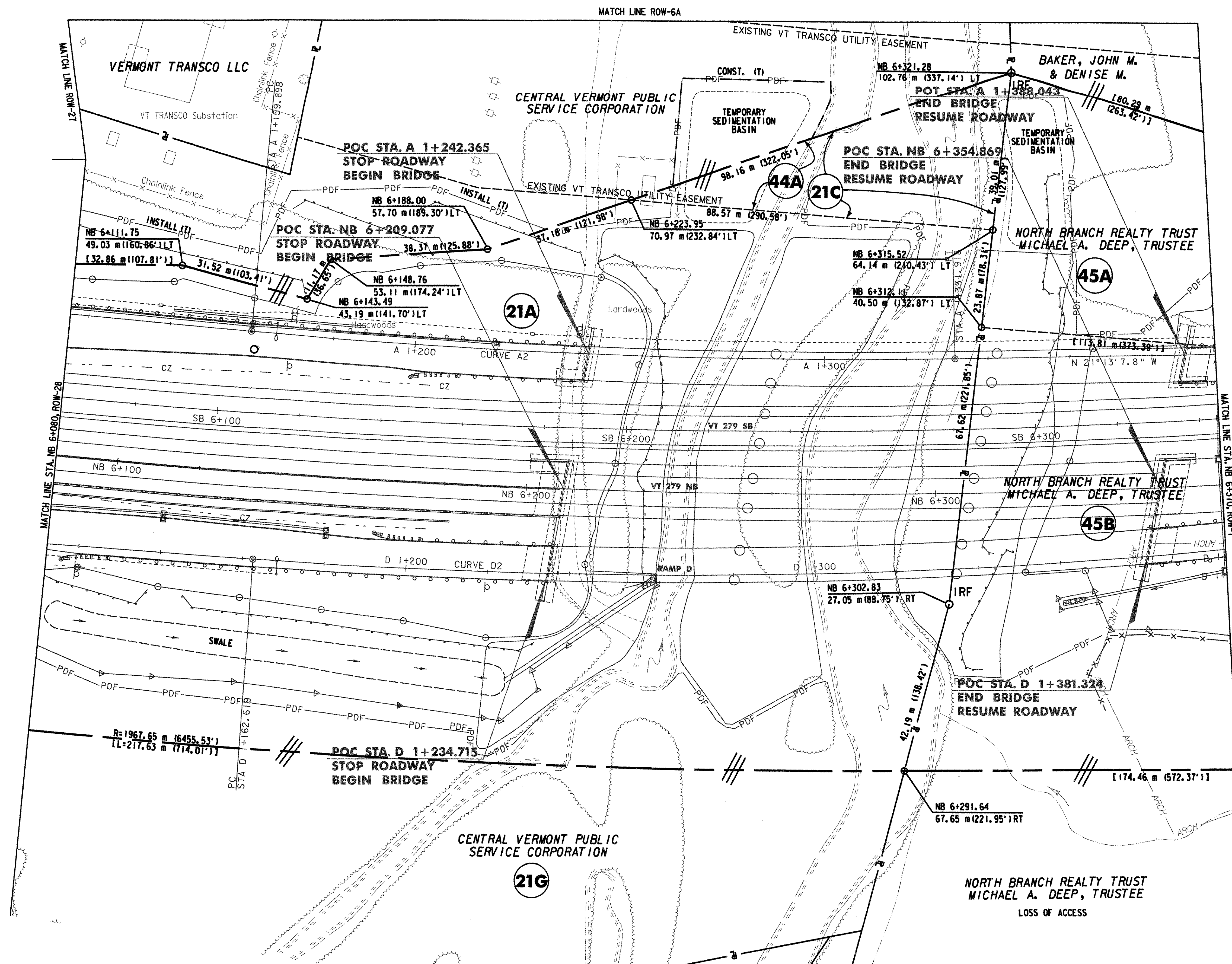

CURVE D2

Δ = 13° 35' 37.7" LT.
 R. = 1375.000m
 T. = 163.883m
 L. = 326.228m
 E. = 9.732m
 BANK = 0.020
 PI STA. D1+326.502
 N = 42897.6240
 E = 445165.6290
 PC N = 42739.9592
 E = 445210.3454
 PT N = 43040.3620
 E = 445085.1082

CURVE A2

Δ = 6° 34' 14.6" LT.
 R. = 1500.000m
 T. = 86.105m
 L. = 172.021m
 E. = 2.469m
 BANK = 0.020
 PI STA. A1+246.003
 N = 42803.8050
 E = 445136.2470
 PC N = 42720.4993
 E = 445158.0213
 PT N = 42884.0719
 E = 445105.0832

CURVE SB5

Δ = 60° 16' 16.5" LT.
 R. = 1820.000m
 T. = 1056.530m
 L. = 1914.516m
 E. = 284.437m
 BANK = 0.032
 PI STA. SB5+743.932
 N = 42277.9017
 E = 445532.0537
 PCC N = 41350.4354
 E = 445026.0287
 PT N = 43177.2504
 E = 444977.5929

CURVE NB5

Δ = 55° 24' 30.7" LT.
 R. = 1900.000m
 T. = 997.703m
 L. = 1837.417m
 E. = 246.022m
 BANK = 0.032
 PI STA. NB5+733.330
 N = 42266.8841
 E = 445508.4114
 PCC N = 41372.0092
 E = 445067.2651
 PT N = 43138.0842
 E = 445022.1796

DATUM
 VERTICAL NAVD 88
 HORIZONTAL NAD 83 (1992)

LINES SHOWN ON THIS PLAN AS EXISTING PROPERTY LINES P/L ARE BELIEVED TO BE ACCURATE BUT SHOULD NOT BE RELIED UPON FOR PURPOSES UNRELATED TO THE STATE OF VERMONT'S ACQUISITION OF LAND AND RIGHTS FOR THIS PROJECT.

THIS SHEET TO BE USED FOR RIGHT-OF-WAY INFORMATION ONLY

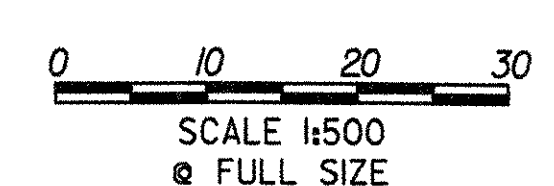

| | | |
|------------------------------|--|----------------------------------|
| R.O.W. PLAN ROW-6 | PROJECT NAME: BENNINGTON BYPASS | PROJECT NUMBER: NH FO19-1(5) |
| | DESIGN FILE NAME: c:\nh\bennington\row | PLOT DATE: 4-25-07 |
| | PROJECT LEADER: JDP | DRAWN BY: MBB CHECKED BY: GAK |
| SHEET: 70 OF 112 | | |

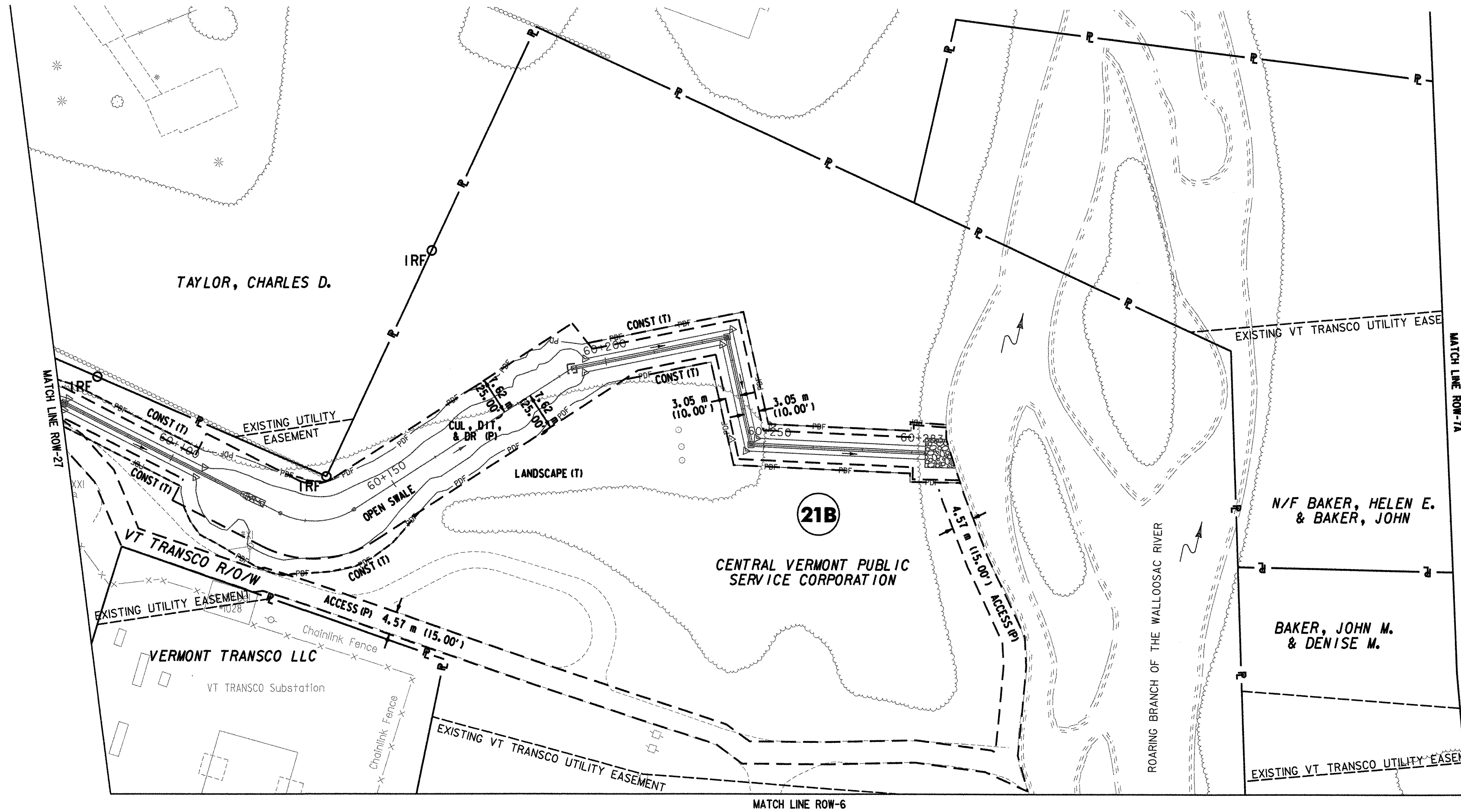
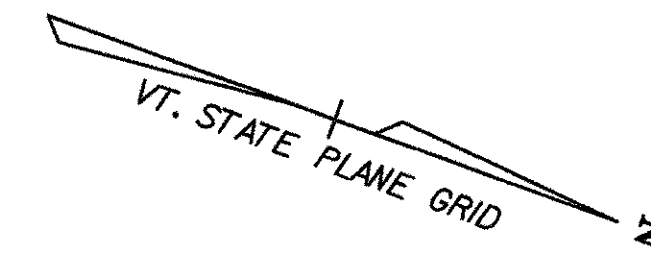

LINES SHOWN ON THIS PLAN AS EXISTING PROPERTY LINES P/L ARE BELIEVED TO BE ACCURATE BUT SHOULD NOT BE RELIED UPON FOR PURPOSES UNRELATED TO THE STATE OF VERMONT'S ACQUISITION OF LAND AND RIGHTS FOR THIS PROJECT.

THIS SHEET TO BE USED FOR RIGHT-OF-WAY INFORMATION ONLY

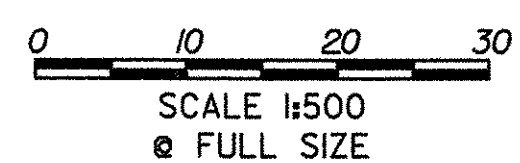

| | |
|--------------|---------------|
| DATUM | |
| VERTICAL | NAVD 88 |
| HORIZONTAL | NAD 83 (1992) |

| | | |
|-----------------------------------|--|---------------------------------|
| R.O.W. PLAN ROW-6A | PROJECT NAME: BENNINGTON BYPASS | PROJECT NUMBER: NH FO19-1(5) |
| | DESIGN FILE NAME: c:\dh\bennington\row | PLOT DATE: 3-26-07 |
| | PROJECT LEADER: JDP | DRAWN BY: MBB |
| | | CHECKED BY: GAK |
| | | SHEET: 71 OF 112 |

VT. STATE PLANE GRID

| CURVE NB5 | CURVE SB5 | CURVE A3 | CURVE D2 | CURVE VRI |
|--|---|---|---|--|
| Δ = 55°24'30.7" LT. R. = 1900.000m T. = 997.703m L. = 1837.417m E. = 246.022m BANK = 0.032 PI STA. NB5+733.330 N = 42266.8841 E = 445508.4114 PCC N = 41372.0092 E = 445067.2651 PT N = 43138.0842 E = 445022.1796 | Δ = 60°16'16.5" LT. R. = 1820.000m T. = 1056.530m L. = 1914.516m E. = 284.437m BANK = 0.032 PI STA. SB5+743.932 N = 42277.9017 E = 445532.0537 PCC N = 41350.4354 E = 445026.0287 PT N = 43177.2504 E = 444977.5929 | Δ = 5°39'26.0" LT. R. = 450.000m T. = 22.234m L. = 44.432m E. = 0.549m BANK = 0.020 PI STA. A1+644.917 N = 43175.8508 E = 444991.7992 PC N = 43155.1242 E = 444999.8463 PT N = 43195.6832 E = 444981.7481 | Δ = 13°35'37.7" LT. R. = 1375.000m T. = 163.883m L. = 326.228m E. = 9.732m BANK = 0.020 PI STA. D1+326.502 N = 42897.6240 E = 445165.6290 PC N = 42739.9592 E = 445210.3454 PT N = 43040.3620 E = 445085.1082 | Δ = 76°07'56.8" RT. R. = 15.000m T. = 11.747m L. = 19.931m E. = 4.052m BANK = N/A PI STA. VRI+030.968 N = 43224.4220 E = 445027.0230 PC N = 43228.7195 E = 445037.9559 PT N = 43234.0062 E = 445020.2304 |

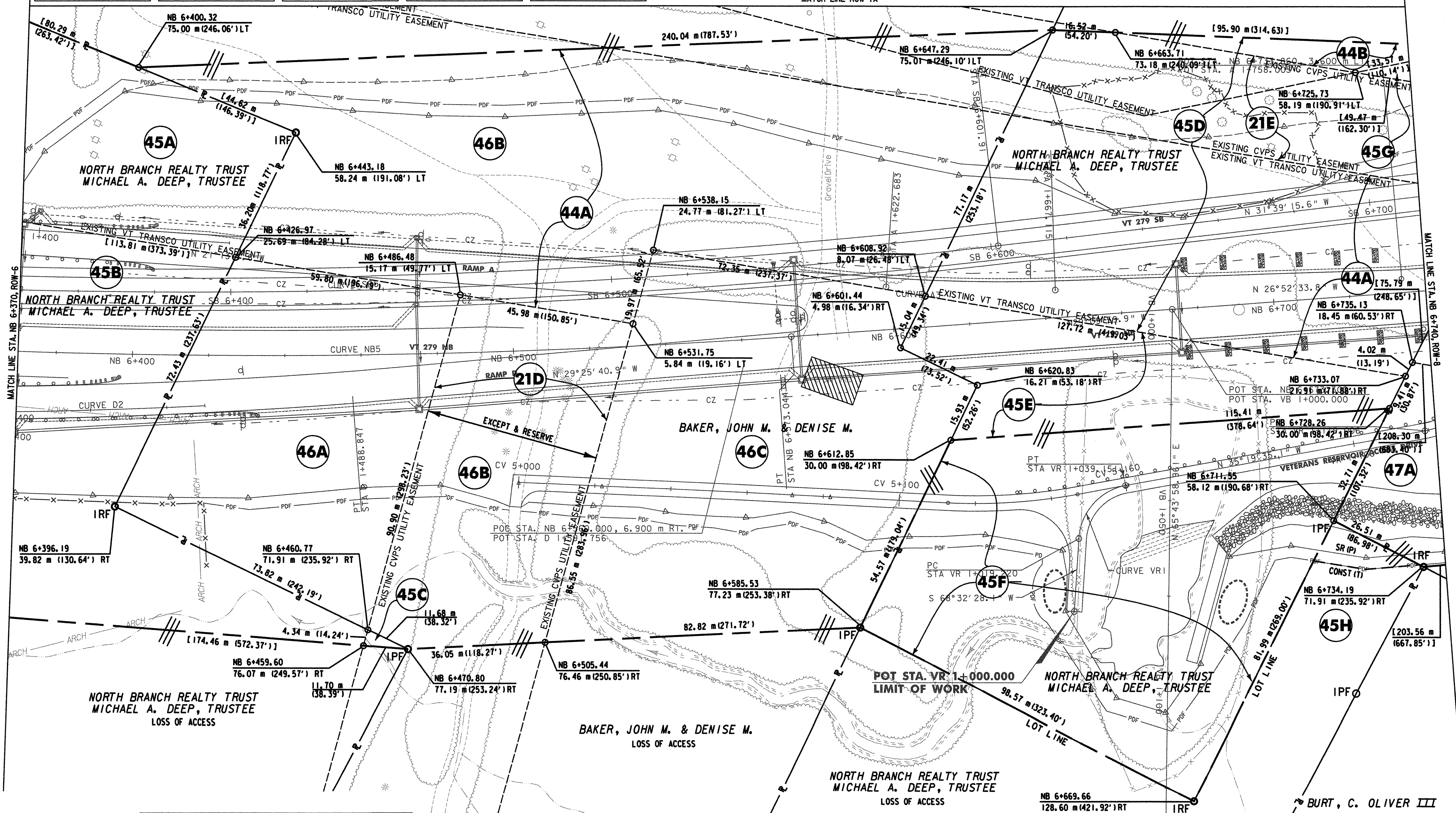

LINES SHOWN ON THIS PLAN AS EXISTING PROPERTY LINES P/L ARE BELIEVED TO BE ACCURATE BUT SHOULD NOT BE RELIED UPON FOR PURPOSES UNRELATED TO THE STATE OF VERMONT'S ACQUISITION OF LAND AND RIGHTS FOR THIS PROJECT.

THIS SHEET TO BE USED FOR RIGHT-OF-WAY INFORMATION ONLY

DATUM
VERTICAL NAVD 88
HORIZONTAL NAD 83 (1992)

0 10 20 30
SCALE 1:500
@ FULL SIZE

**R.O.W.
PLAN
ROW-7**

PROJECT NAME: BENNINGTON BYPASS
DESIGN FILE NAME: c:\dh\bennington\row
PROJECT LEADER: JDP

PROJECT NUMBER: NH FO19-(K5)
PLOT DATE: 3-26-07
DRAWN BY: MBB
CHECKED BY: GAK

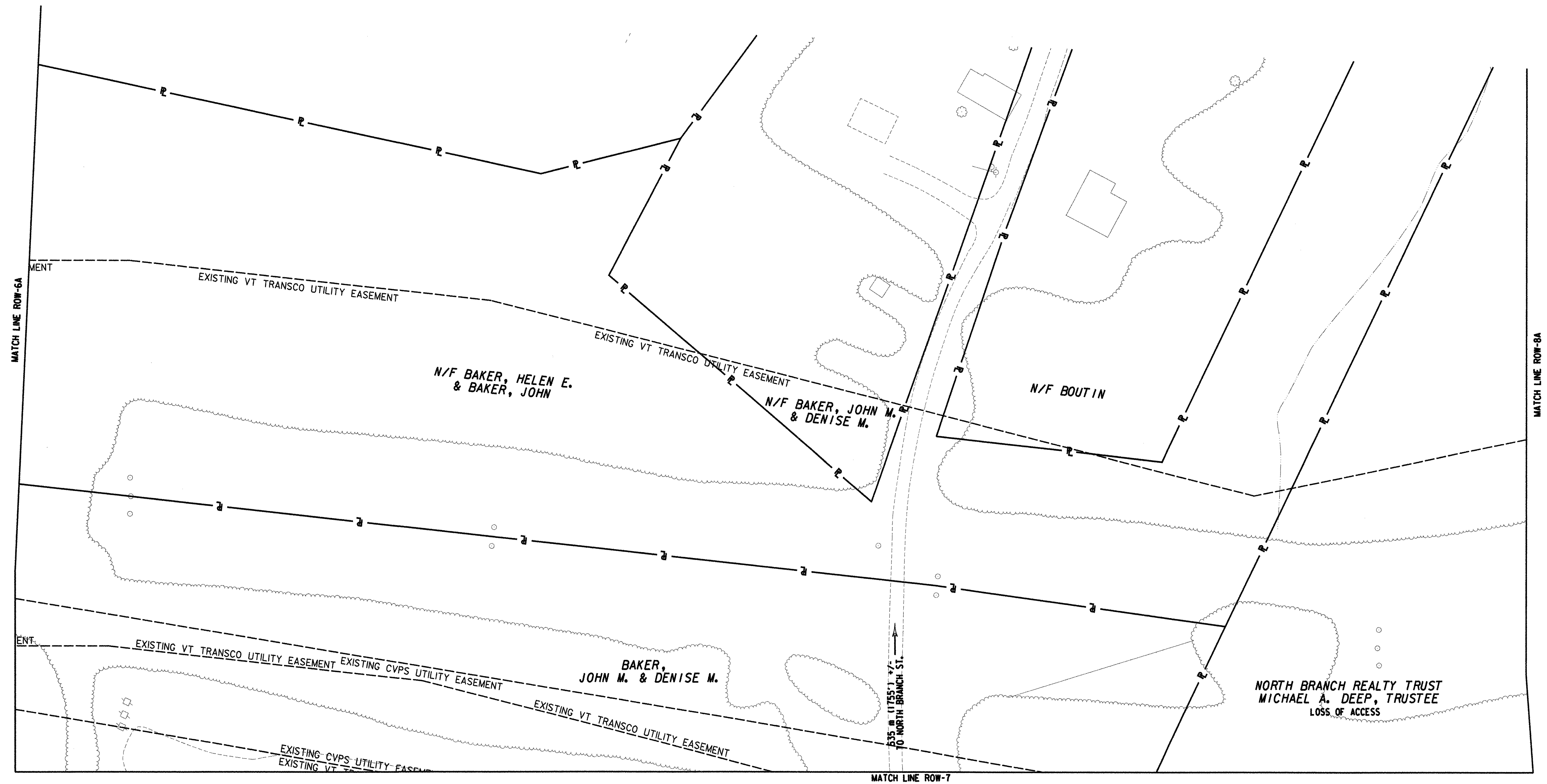
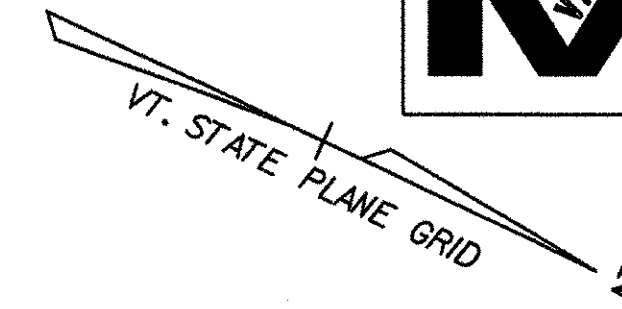

DATUM
 VERTICAL NAVD 88
 HORIZONTAL NAD 83 (1992)

LINES SHOWN ON THIS PLAN AS EXISTING PROPERTY LINES P/L ARE BELIEVED TO BE ACCURATE BUT SHOULD NOT BE RELIED UPON FOR PURPOSES UNRELATED TO THE STATE OF VERMONT'S ACQUISITION OF LAND AND RIGHTS FOR THIS PROJECT.

THIS SHEET TO BE USED FOR RIGHT-OF-WAY INFORMATION ONLY

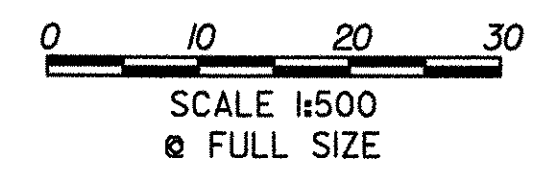

**R.O.W. PLAN
 ROW-7A**

PROJECT NAME: **BENNINGTON BYPASS**
 DESIGN FILE NAME: c:\nh\bennington\row
 PROJECT LEADER: JDP

PROJECT NUMBER: **NH FO19-1(5)**
 PLOT DATE: 3-26-07
 DRAWN BY: MBB
 CHECKED BY: GAK
 SHEET: **73** OF **112**

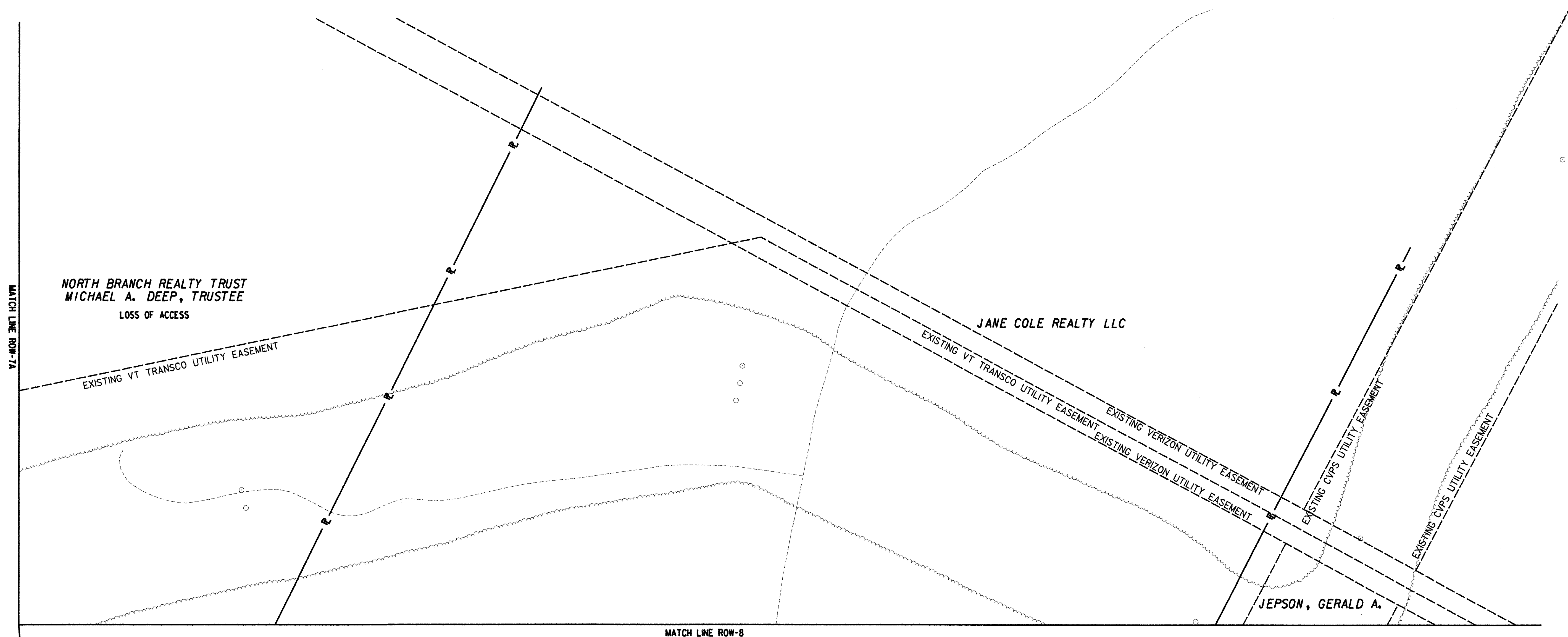
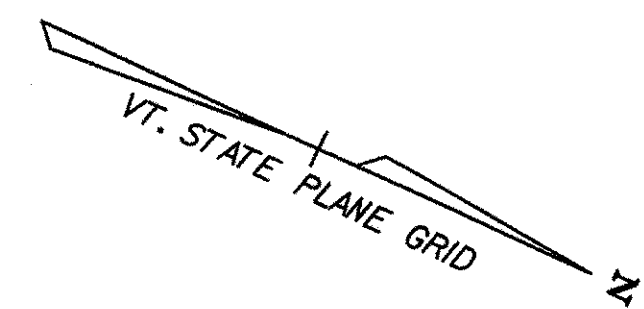

DATUM
 VERTICAL NAVD 88
 HORIZONTAL NAD 83 (1992)

LINES SHOWN ON THIS PLAN AS EXISTING PROPERTY LINES P/L ARE BELIEVED TO BE ACCURATE BUT SHOULD NOT BE RELIED UPON FOR PURPOSES UNRELATED TO THE STATE OF VERMONT'S ACQUISITION OF LAND AND RIGHTS FOR THIS PROJECT.

THIS SHEET TO BE USED FOR RIGHT-OF-WAY INFORMATION ONLY

0 10 20 30
 SCALE 1:500
 @ FULL SIZE

**R.O.W.
 PLAN
 ROW-8A**

PROJECT NAME: BENNINGTON BYPASS
 DESIGN FILE NAME: o:\dh\bennington\row
 PROJECT LEADER: JDP

PROJECT NUMBER: NH F019-1(5)

PLOT DATE: 3-26-07
 DRAWN BY: MBB
 CHECKED BY: GAK

SHEET: 75 OF 112

| CURVE Bm-3 | CURVE Bm-4 |
|------------------------------------|-----------------------------------|
| $\Delta = 89^{\circ}43'41.6''$ RT. | $\Delta = 18^{\circ}36'7.5''$ LT. |
| R. = 4.000m | R. = 30.000m |
| T. = 3.981m | T. = 4.913m |
| L. = 6.264m | L. = 9.740m |
| E. = 1.643m | E. = 0.400m |
| BANK= N/A | BANK= N/A |
| PI STA. Bm-0+090.662 | PI STA. Bm-0+130.763 |

| CURVE NB6 | CURVE SB6 | CURVE Bm1 | CURVE Bm2 |
|------------------------------------|------------------------------------|------------------------------------|------------------------------------|
| $\Delta = 29^{\circ}55'02.1''$ RT. | $\Delta = 32^{\circ}24'15.3''$ RT. | $\Delta = 71^{\circ}33'14.0''$ LT. | $\Delta = 81^{\circ}08'46.7''$ RT. |
| R. = 1100.000m | R. = 1175.000m | R. = 15.000m | R. = 5.000m |
| T. = 293.893m | T. = 341.416m | T. = 10.809 m | T. = 4.281 m |
| L. = 574.370m | L. = 664.534m | L. = 18.733 m | L. = 7.081 m |
| E. = 38.584m | E. = 48.597m | E. = 3.489 m | E. = 1.583 m |
| BANK= 0.045 | BANK= 0.046 | BANK= N/A | BANK= N/A |
| PI STA. NB7+198.684 | PI STA. SB7+151.341 | PI STA. Bm1+011.492 | PI STA. Bm2+038.643 |
| N = 43684.3970 | N = 43644.9355 | N = 43623.3510 | N = 43653.1631 |
| E = 444717.2730 | E = 444689.2599 | E = 444732.0530 | E = 444728.3892 |
| PC N = 43427.7680 | PC N = 43354.3120 | PC N = 43618.7056 | PC N = 43648.9137 |
| E = 444860.5020 | E = 444868.4320 | E = 444722.2929 | E = 444728.9114 |
| PT N = 43978.2646 | PT N = 43986.3230 | PT N = 43634.0795 | PT N = 43654.3332 |
| E = 444721.1230 | E = 444693.7290 | E = 444730.7345 | E = 444732.5077 |

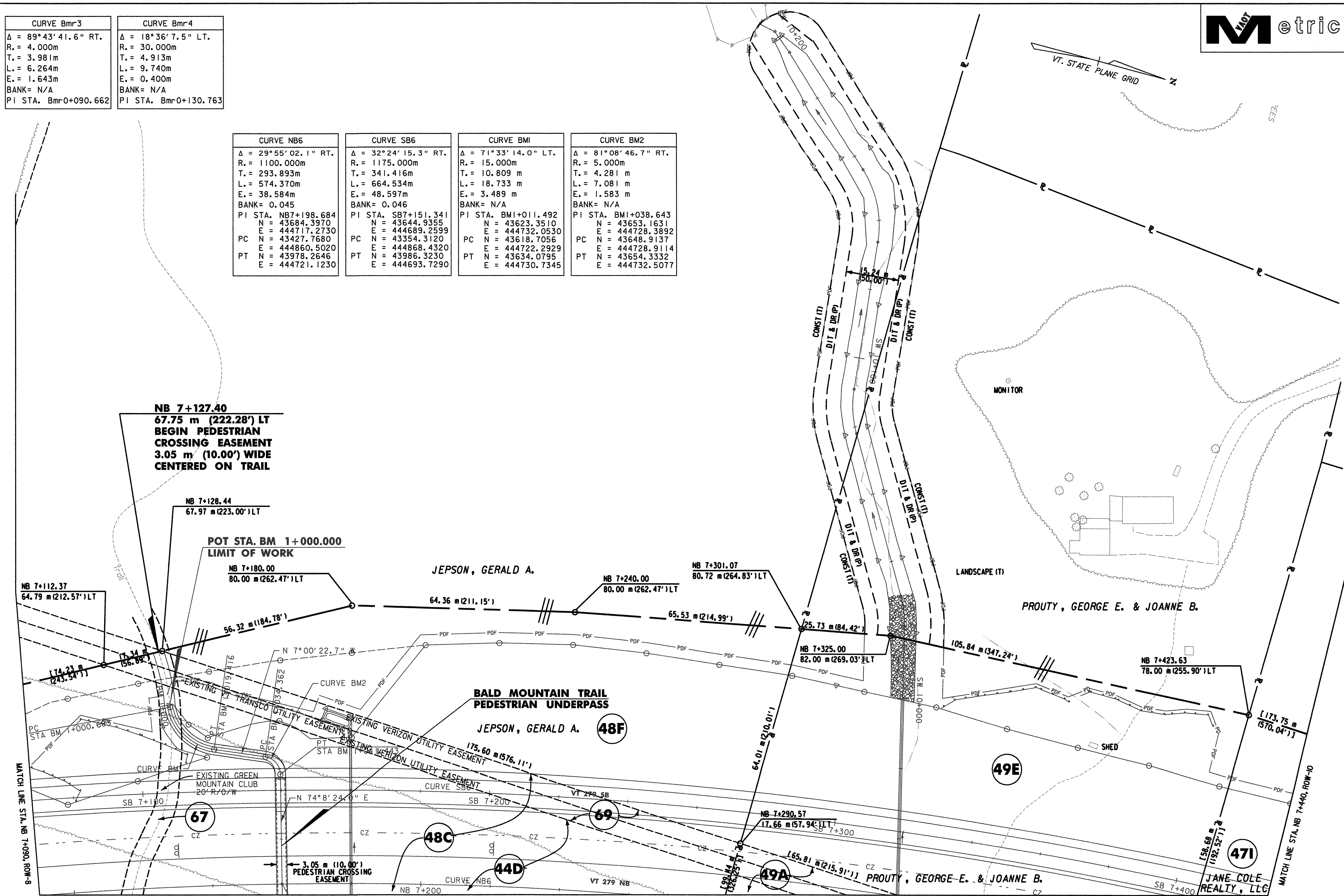

NB 7+127.40
67.75 m (222.28') LT
BEGIN PEDESTRIAN
CROSSING EASEMENT
3.05 m (10.00') WIDE
CENTERED ON TRAIL

NB 7+128.44
67.97 m (223.00') LT
POT STA. BM 1+000.000
LIMIT OF WORK

NB 7+180.00
80.00 m (262.47') LT

NB 7+112.37
64.79 m (212.57') LT

JEPSON, GERALD A.

NB 7+240.00
80.00 m (262.47') LT

NB 7+301.07
80.72 m (264.83') LT

NB 7+325.00
82.00 m (269.03') LT

NB 7+423.63
78.00 m (255.90') LT

BALD MOUNTAIN TRAIL
PEDESTRIAN UNDERPASS

JEPSON, GERALD A. 48F

PROUTY, GEORGE E. & JOANNE B.

MATCH LINE STA. NB 7+090, ROW-8

MATCH LINE STA. NB 7+440, ROW-10

LINES SHOWN ON THIS PLAN AS EXISTING PROPERTY LINES P/L ARE BELIEVED TO BE ACCURATE BUT SHOULD NOT BE RELIED UPON FOR PURPOSES UNRELATED TO THE STATE OF VERMONT'S ACQUISITION OF LAND AND RIGHTS FOR THIS PROJECT.

THIS SHEET TO BE USED FOR RIGHT-OF-WAY INFORMATION ONLY

DATUM
 VERTICAL NAVD 88
 HORIZONTAL NAD 83 (1992)

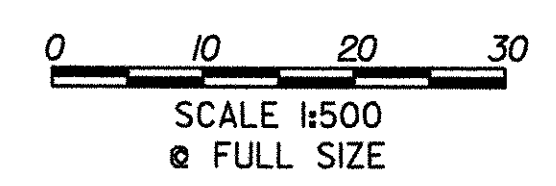

| | | |
|------------------------------------|--|---------------------------------|
| R.O.W. PLAN ROW-9 | PROJECT NAME: BENNINGTON BYPASS | PROJECT NUMBER: NH FO19-1(5) |
| | DESIGN FILE NAME: c:\dh\bennington\row | PLOT DATE: 3-26-07 |
| | PROJECT LEADER: JDP | DRAWN BY: MBB |
| | | CHECKED BY: GAK |
| | | SHEET: 76 OF 112 |

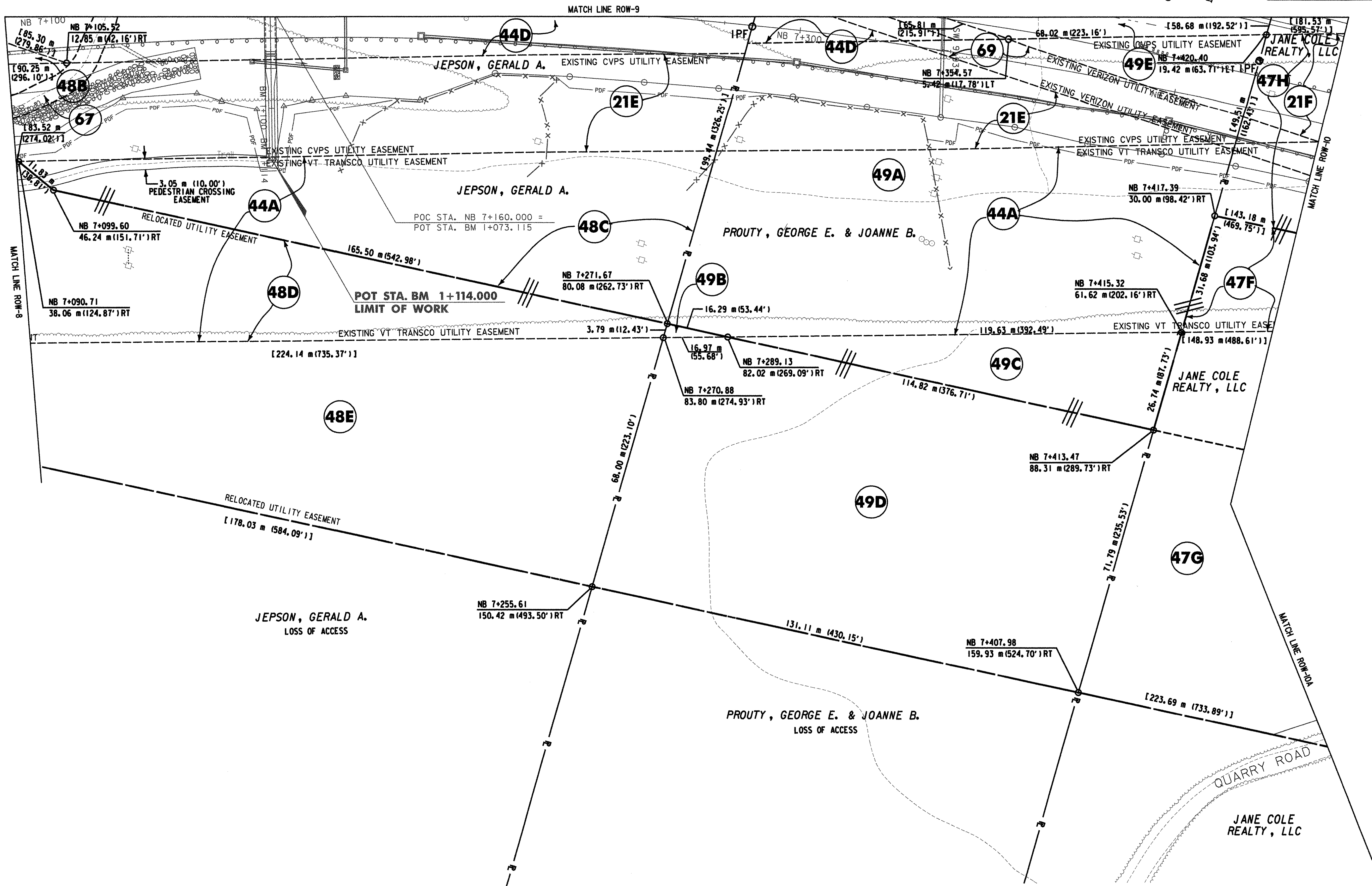

THIS SHEET TO BE USED FOR RIGHT-OF-WAY INFORMATION ONLY

DATUM
 VERTICAL NAVD 88
 HORIZONTAL NAD 83 (1992)

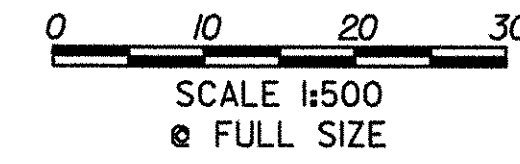

| | | |
|-----------------------------------|--|----------------------------------|
| R.O.W. PLAN ROW-9A | PROJECT NAME: BENNINGTON BYPASS | PROJECT NUMBER: NH FO19-1(5) |
| | DESIGN FILE NAME: c:\dh\bennington\row | PLOT DATE: 3-26-07 |
| | PROJECT LEADER: JDP | DRAWN BY: MBB CHECKED BY: GAK |
| SHEET: 77 OF 112 | | |

| CURVE NB6 | CURVE SB6 |
|------------------------------------|------------------------------------|
| $\Delta = 29^{\circ}55'02.1''$ RT. | $\Delta = 32^{\circ}24'15.3''$ RT. |
| R. = 1100.000m | R. = 1175.000m |
| T. = 293.893m | T. = 341.416m |
| L. = 574.370m | L. = 664.534m |
| E. = 38.584m | E. = 48.597m |
| BANK = 0.045 | BANK = 0.046 |
| PI STA. NB7+198.684 | PI STA. SB7+151.341 |
| N = 43684.3970 | N = 43644.9355 |
| E = 444717.2730 | E = 444689.2599 |
| PC N = 43427.7680 | PC N = 43354.3120 |
| E = 444860.5020 | E = 444868.4320 |
| PT N = 43978.2646 | PT N = 43986.3230 |
| E = 444721.1230 | E = 444693.7290 |

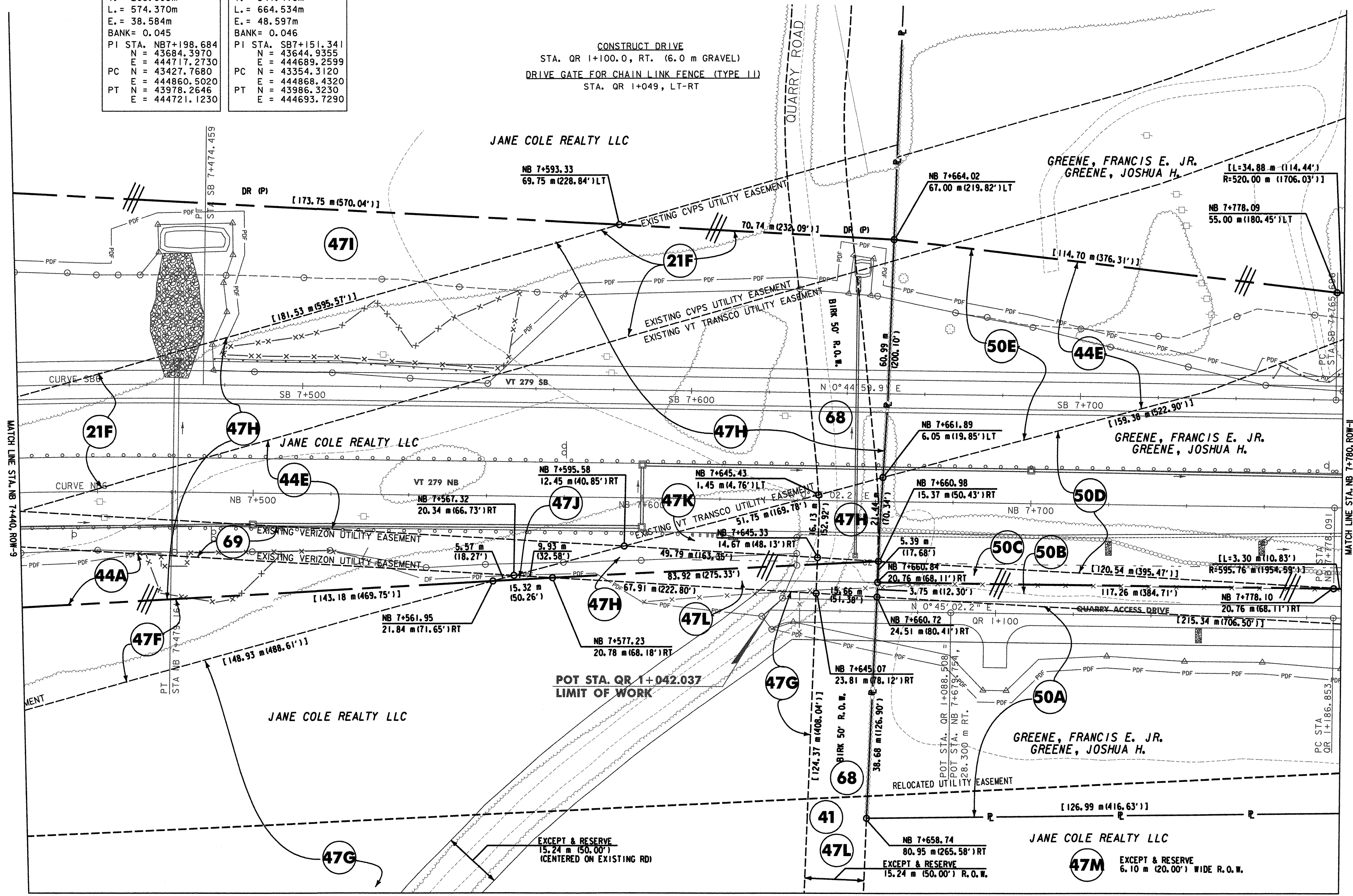

LINES SHOWN ON THIS PLAN AS EXISTING PROPERTY LINES P/L ARE BELIEVED TO BE ACCURATE BUT SHOULD NOT BE RELIED UPON FOR PURPOSES UNRELATED TO THE STATE OF VERMONT'S ACQUISITION OF LAND AND RIGHTS FOR THIS PROJECT.

THIS SHEET TO BE USED FOR RIGHT-OF-WAY INFORMATION ONLY

DATUM
 VERTICAL NAVD 88
 HORIZONTAL NAD 83 (1992)

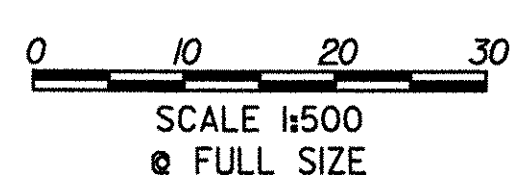

| | | |
|-------------------------------------|--|----------------------------------|
| R.O.W. PLAN ROW-10 | PROJECT NAME: BENNINGTON BYPASS | PROJECT NUMBER: NH FO19-1(5) |
| | DESIGN FILE NAME: c:\dh\bennington\row | PLOT DATE: 3-26-07 |
| | PROJECT LEADER: JDP | DRAWN BY: MBB CHECKED BY: GAK |
| | | SHEET: 78 OF 112 |

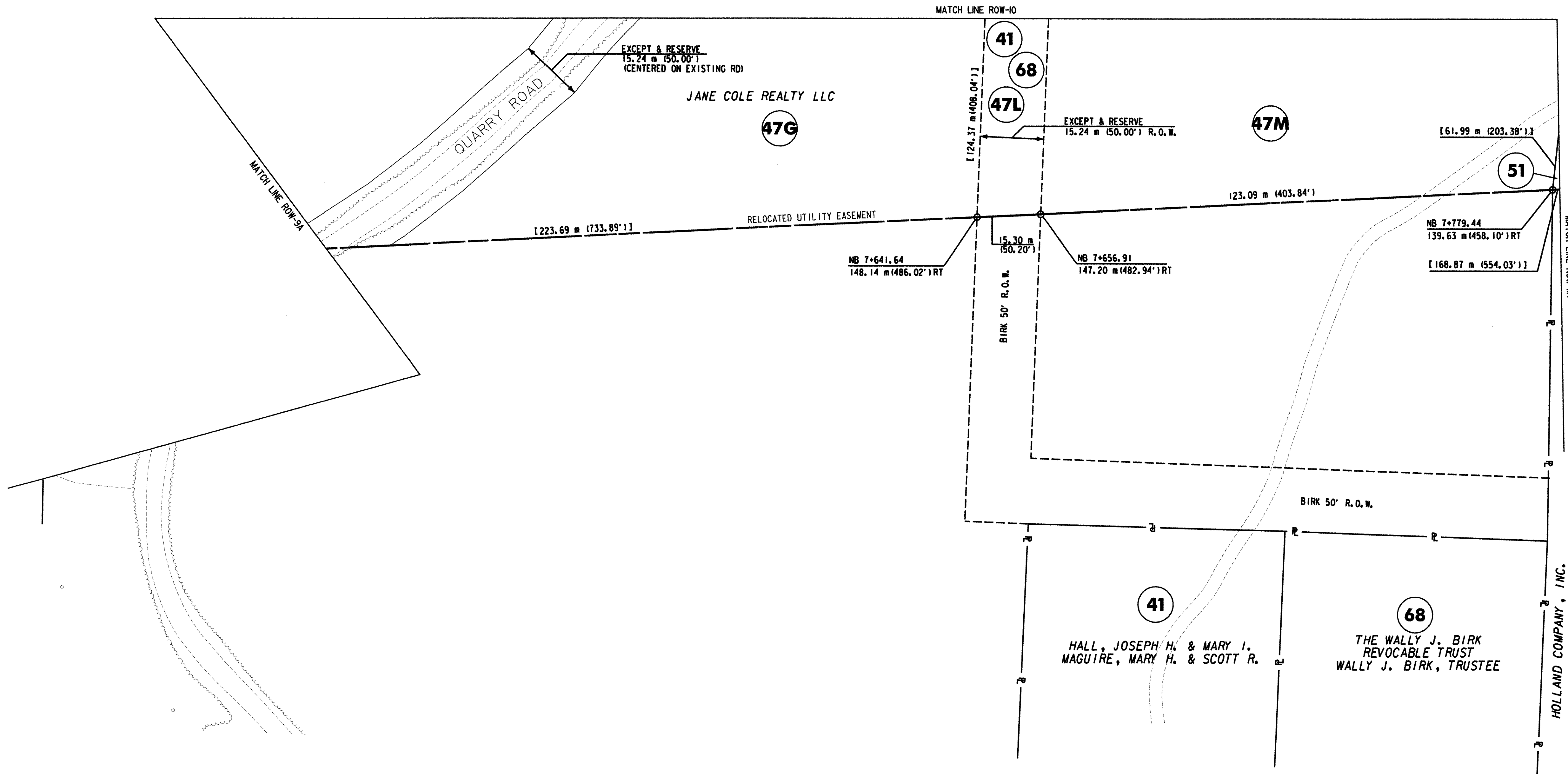

DATUM
 VERTICAL NAVD 88
 HORIZONTAL NAD 83 (1992)

LINES SHOWN ON THIS PLAN AS EXISTING PROPERTY LINES P/L ARE BELIEVED TO BE ACCURATE BUT SHOULD NOT BE RELIED UPON FOR PURPOSES UNRELATED TO THE STATE OF VERMONT'S ACQUISITION OF LAND AND RIGHTS FOR THIS PROJECT.

THIS SHEET TO BE USED FOR RIGHT-OF-WAY INFORMATION ONLY

0 10 20 30
 SCALE 1:500
 @ FULL SIZE

| | | |
|--|--|----------------------------------|
| R.O.W. PLAN ROW-10A | PROJECT NAME: BENNINGTON BYPASS | PROJECT NUMBER: NH F019-1(5) |
| | DESIGN FILE NAME: c:\dh\bennington\row | PLOT DATE: 1-30-06 |
| | PROJECT LEADER: JDP | DRAWN BY: MBB CHECKED BY: GAK |
| | | SHEET: 79 OF 112 |

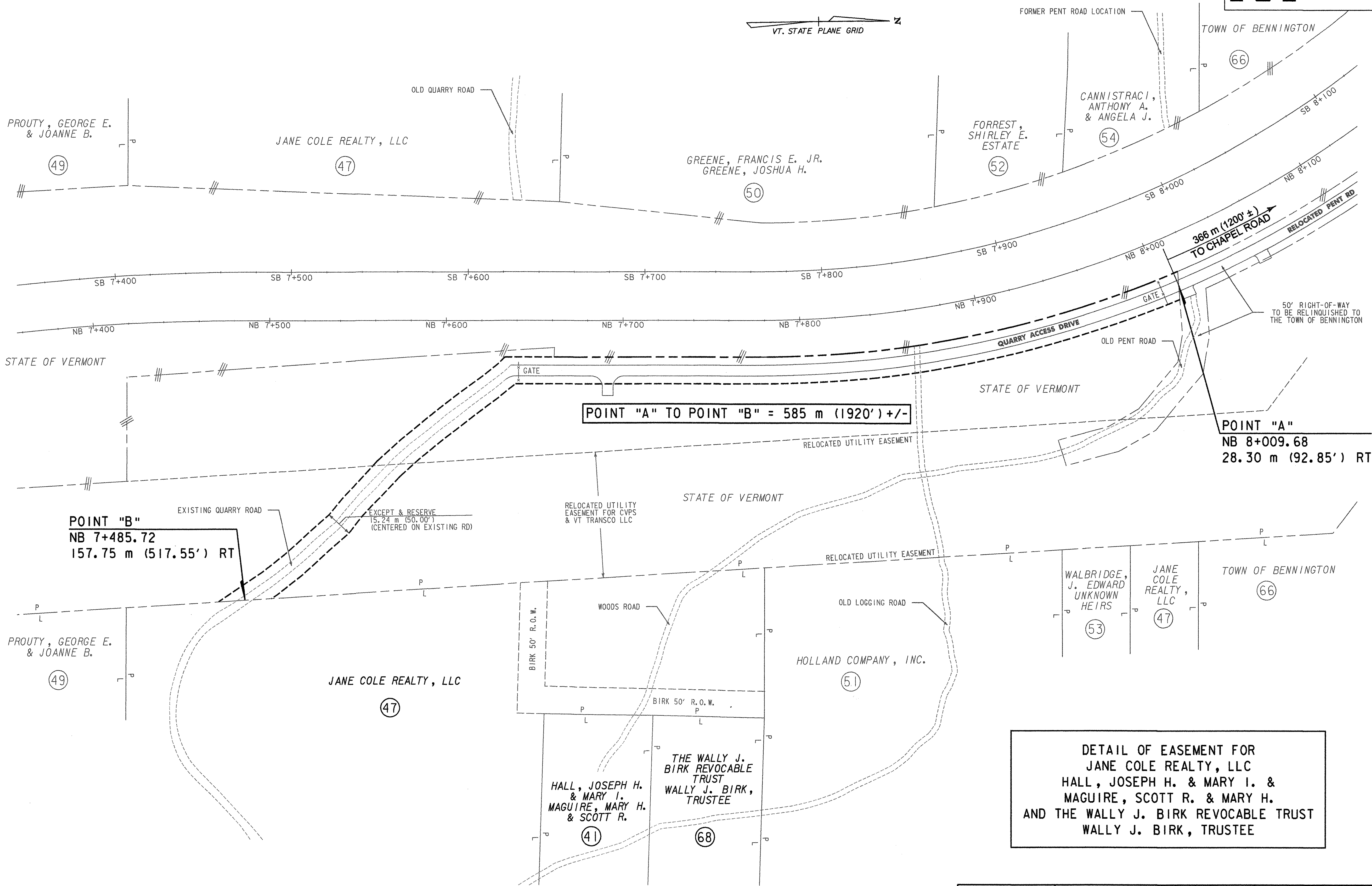

POINT "B"
 NB 7+485.72
 157.75 m (517.55') RT

POINT "A" TO POINT "B" = 585 m (1920') +/-

POINT "A"
 NB 8+009.68
 28.30 m (92.85') RT

**DETAIL OF EASEMENT FOR
 JANE COLE REALTY, LLC
 HALL, JOSEPH H. & MARY I. &
 MAGUIRE, SCOTT R. & MARY H.
 AND THE WALLY J. BIRK REVOCABLE TRUST
 WALLY J. BIRK, TRUSTEE**

LINES SHOWN ON THIS PLAN AS EXISTING PROPERTY LINES P/L ARE BELIEVED TO BE ACCURATE BUT SHOULD NOT BE RELIED UPON FOR PURPOSES UNRELATED TO THE STATE OF VERMONT'S ACQUISITION OF LAND AND RIGHTS FOR THIS PROJECT.

THIS SHEET TO BE USED FOR RIGHT-OF-WAY INFORMATION ONLY

DATUM
 VERTICAL NAVD 88
 HORIZONTAL NAD 83 (1992)

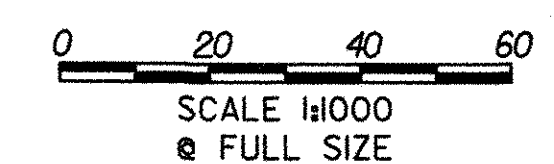

| | | |
|------------------------------------|--|----------------------------------|
| R.O.W. PLAN ROW-10B | PROJECT NAME: BENNINGTON | PROJECT NUMBER: NH FO19-1(5) |
| | DESIGN FILE NAME: c:\dh\bennington\row | PLOT DATE: 6-8-07 |
| | PROJECT LEADER: JDP | DRAWN BY: MBB CHECKED BY: GAK |
| SHEET: 79-A OF 112 | | |

| CURVE NB7 | |
|-----------|-----------------|
| Δ | = 90° 45' 02.2" |
| R. | = 575.000m |
| T. | = 582.583m |
| L. | = 910.741m |
| E. | = 243.552m |
| BANK | = 0.078 |
| PI STA. | NB8+360.674 |
| N | = 44859.7020 |
| E | = 444732.6710 |
| PC N | = 44277.1693 |
| E | = 444725.0391 |
| PT N | = 44859.7019 |
| E | = 444150.0883 |

| CURVE SB7 | |
|-----------|----------------|
| Δ | = 90° 45' 0.1" |
| R. | = 547.500m |
| T. | = 554.714m |
| L. | = 867.178m |
| E. | = 231.900m |
| BANK | = N/A |
| PI STA. | SB8+320.410 |
| N | = 44832.2019 |
| E | = 444704.8017 |
| PC N | = 44277.5357 |
| E | = 444697.5410 |
| PT N | = 44832.2019 |
| E | = 444150.0879 |

| CURVE QR1 | |
|-----------|-----------------|
| Δ | = 57° 51' 50.8" |
| R. | = 603.300m |
| T. | = 333.480m |
| L. | = 609.284m |
| E. | = 86.033m |
| BANK | = N/A |
| PI STA. | QR1+520.333 |
| N | = 44610.2574 |
| E | = 444757.7022 |
| PC N | = 44276.8060 |
| E | = 444753.3381 |
| PT N | = 44791.3254 |
| E | = 444477.6607 |

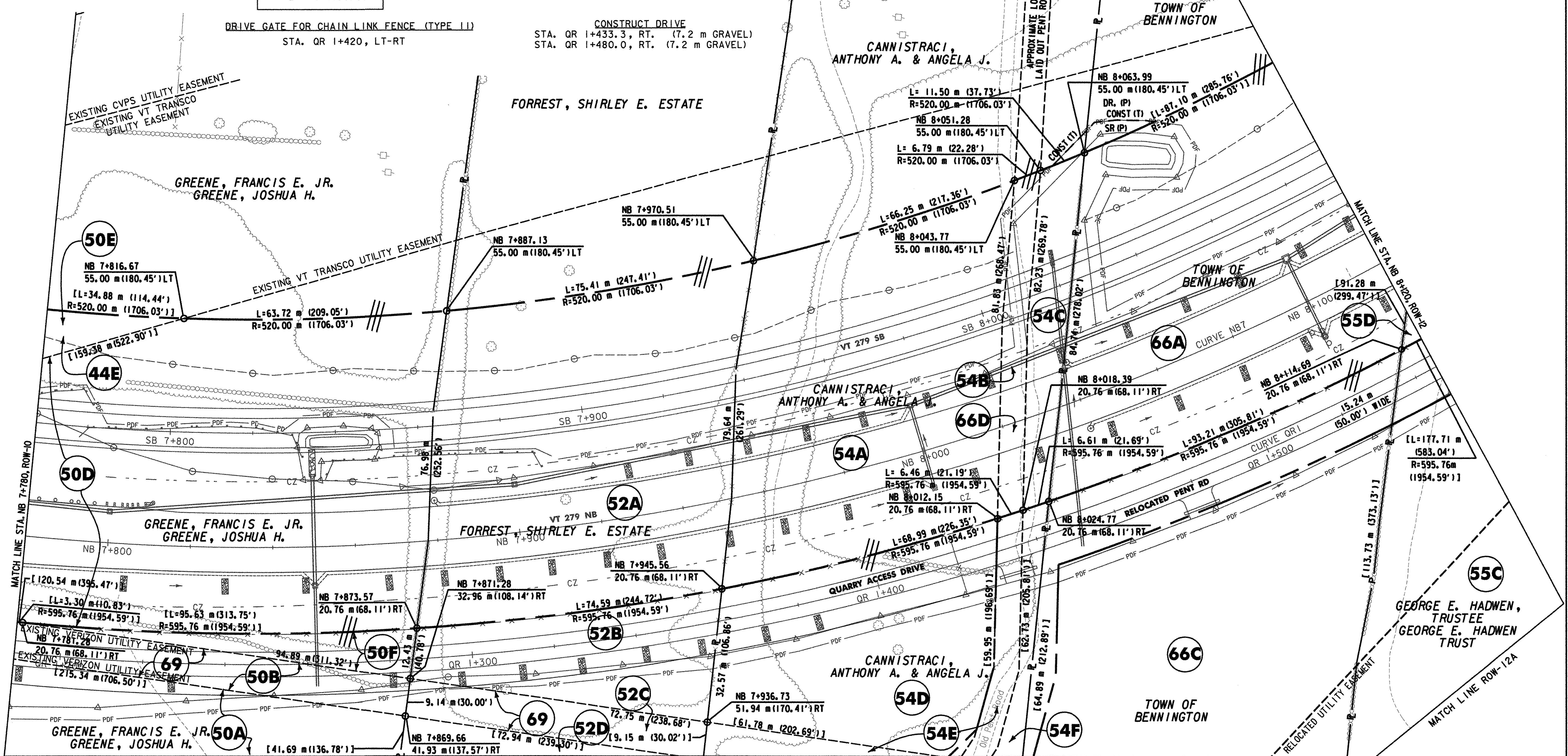

DATUM
 VERTICAL NAVD 88
 HORIZONTAL NAD 83 (1992)

LINES SHOWN ON THIS PLAN AS EXISTING PROPERTY LINES P/L ARE BELIEVED TO BE ACCURATE BUT SHOULD NOT BE RELIED UPON FOR PURPOSES UNRELATED TO THE STATE OF VERMONT'S ACQUISITION OF LAND AND RIGHTS FOR THIS PROJECT.

THIS SHEET TO BE USED FOR RIGHT-OF-WAY INFORMATION ONLY

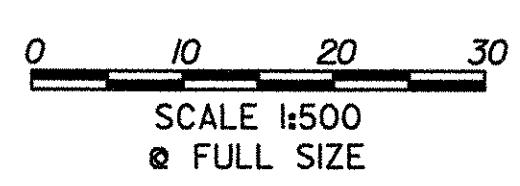

R.O.W. PLAN
ROW-11

PROJECT NAME: BENNINGTON BYPASS
 DESIGN FILE NAME: c:\rdh\bennington\row
 PROJECT LEADER: JDP

PROJECT NUMBER: NH F019-(K5)
 PLOT DATE: 3-26-07
 DRAWN BY: MBB
 CHECKED BY: GAK
 SHEET: 80 OF 112

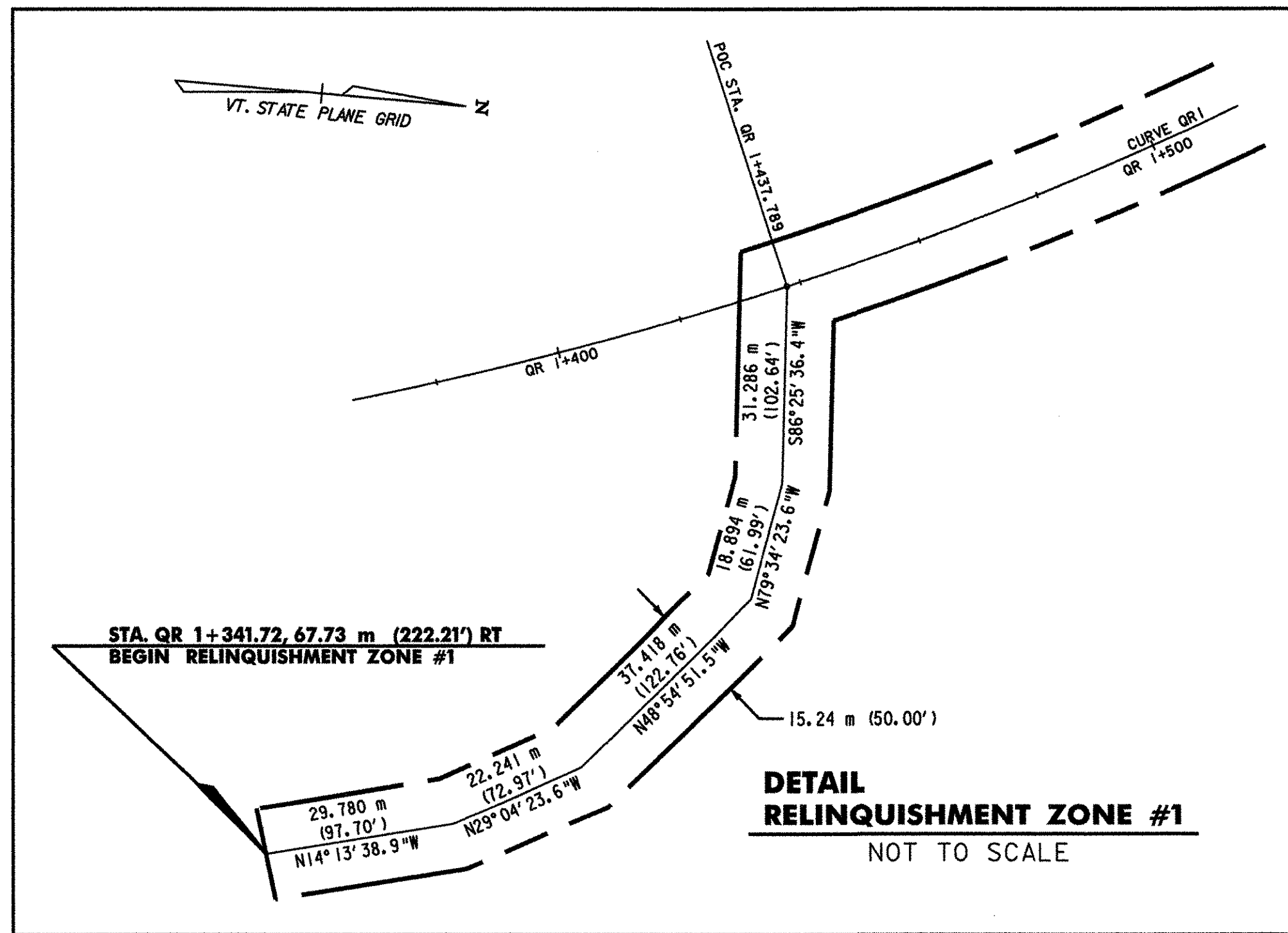
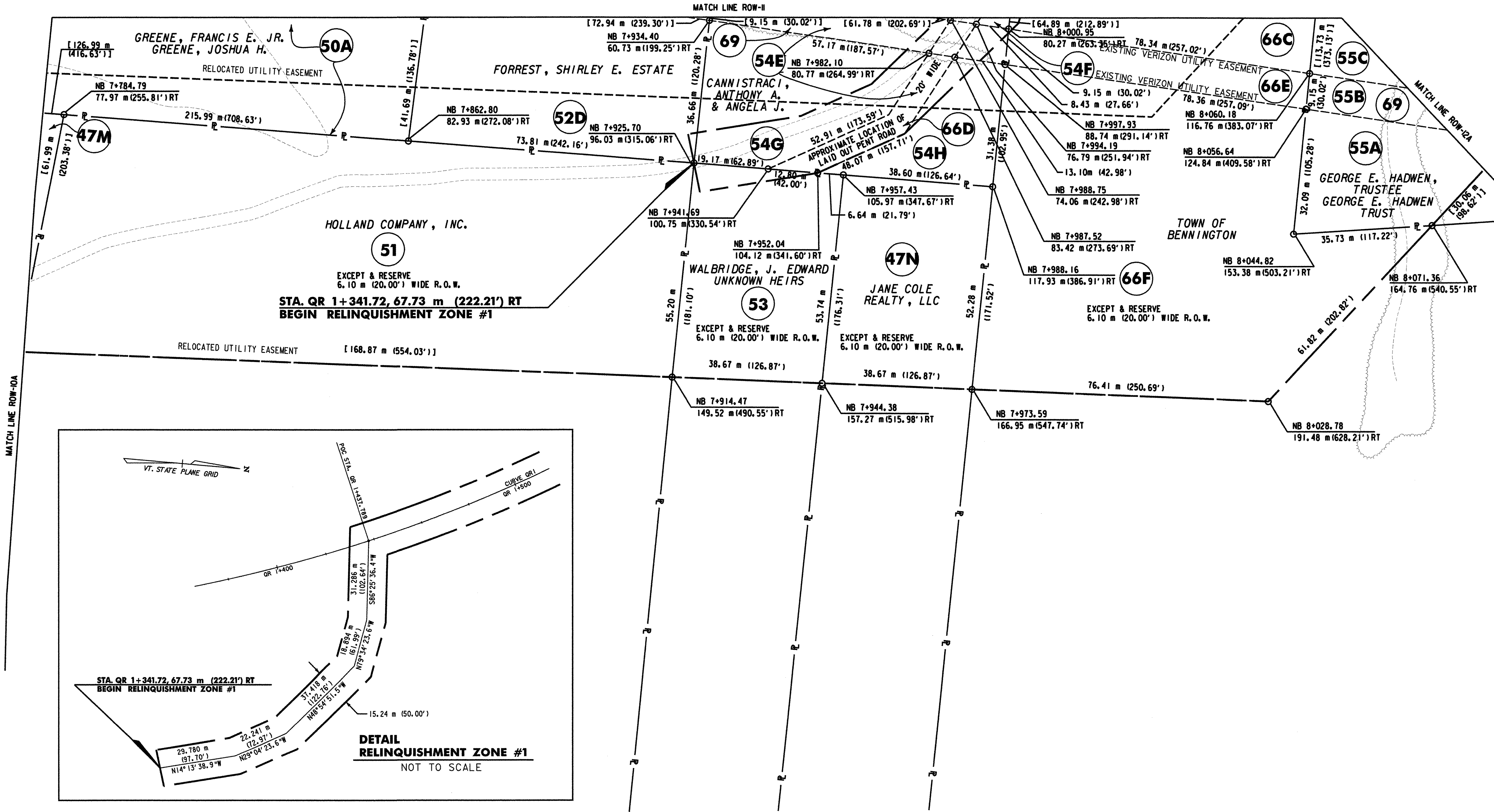

LINES SHOWN ON THIS PLAN AS EXISTING PROPERTY LINES P/L ARE BELIEVED TO BE ACCURATE BUT SHOULD NOT BE RELIED UPON FOR PURPOSES UNRELATED TO THE STATE OF VERMONT'S ACQUISITION OF LAND AND RIGHTS FOR THIS PROJECT.

THIS SHEET TO BE USED FOR RIGHT-OF-WAY INFORMATION ONLY

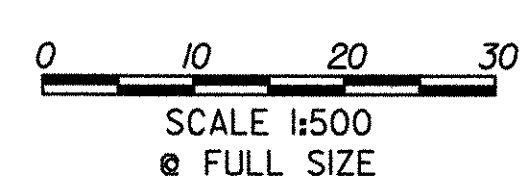

DATUM
VERTICAL NAVD 88
HORIZONTAL NAD 83 (1992)

| | | |
|------------------------------------|--|----------------------------------|
| R.O.W. PLAN ROW-11A | PROJECT NAME: BENNINGTON BYPASS | PROJECT NUMBER: NH FO19-1(5) |
| | DESIGN FILE NAME: c:\dh\bennington\row | PLOT DATE: 1-30-06 |
| | PROJECT LEADER: JDP | DRAWN BY: MBB CHECKED BY: GAK |
| SHEET: 81 OF 112 | | |

| CURVE CHI | CURVE NB7 |
|--------------------------------|--------------------------------|
| $\Delta = 13^{\circ}20'29.3''$ | $\Delta = 90^{\circ}45'02.2''$ |
| R. = 315.411m | R. = 575.000m |
| T. = 36.889m | T. = 582.583m |
| L. = 73.444m | L. = 910.741m |
| E. = 2.150m | E. = 243.552m |
| BANK = 0.044 | BANK = 0.078 |
| PI STA. CH 1+348.535 | PI STA. NB8+360.674 |
| N = 44729.2251 | N = 44859.7020 |
| E = 444458.9346 | E = 444732.6710 |
| PC N = 44692.4025 | PC N = 44277.1693 |
| E = 444456.7224 | E = 444725.0391 |
| PT N = 44764.5435 | PT N = 44859.7019 |
| E = 444469.5841 | E = 444150.0883 |

| CURVE SBT | CURVE QRI |
|-------------------------------|--------------------------------|
| $\Delta = 90^{\circ}45'0.1''$ | $\Delta = 57^{\circ}51'50.8''$ |
| R. = 547.500m | R. = 603.300m |
| T. = 554.714m | T. = 333.480m |
| L. = 867.178m | L. = 609.284m |
| E. = 231.900m | E. = 86.033m |
| BANK = N/A | BANK = N/A |
| PI STA. SB8+320.410 | PI STA. QRI+520.333 |
| N = 44832.2019 | N = 44610.2574 |
| E = 444704.8017 | E = 444757.7022 |
| PC N = 44277.5357 | PC N = 44276.8060 |
| E = 444697.5410 | E = 444753.3381 |
| PT N = 44832.2019 | PT N = 44791.3254 |
| E = 444150.0879 | E = 444477.6607 |

DRIVE GATE FOR CHAIN LINK FENCE (TYPE 11)
 STA. CH 1+412.3, RT. (QUARRY ACCESS ROAD)
 STA. CH 1+320.4, LT.

CONSTRUCT DRIVE
 STA. CH 1+261.6, LT. (7.2 m GRAVEL)
 STA. CH 1+320.4, LT. (3.6 m GRAVEL)
 STA. CH 1+430.6, RT. (4.5 m GRAVEL)

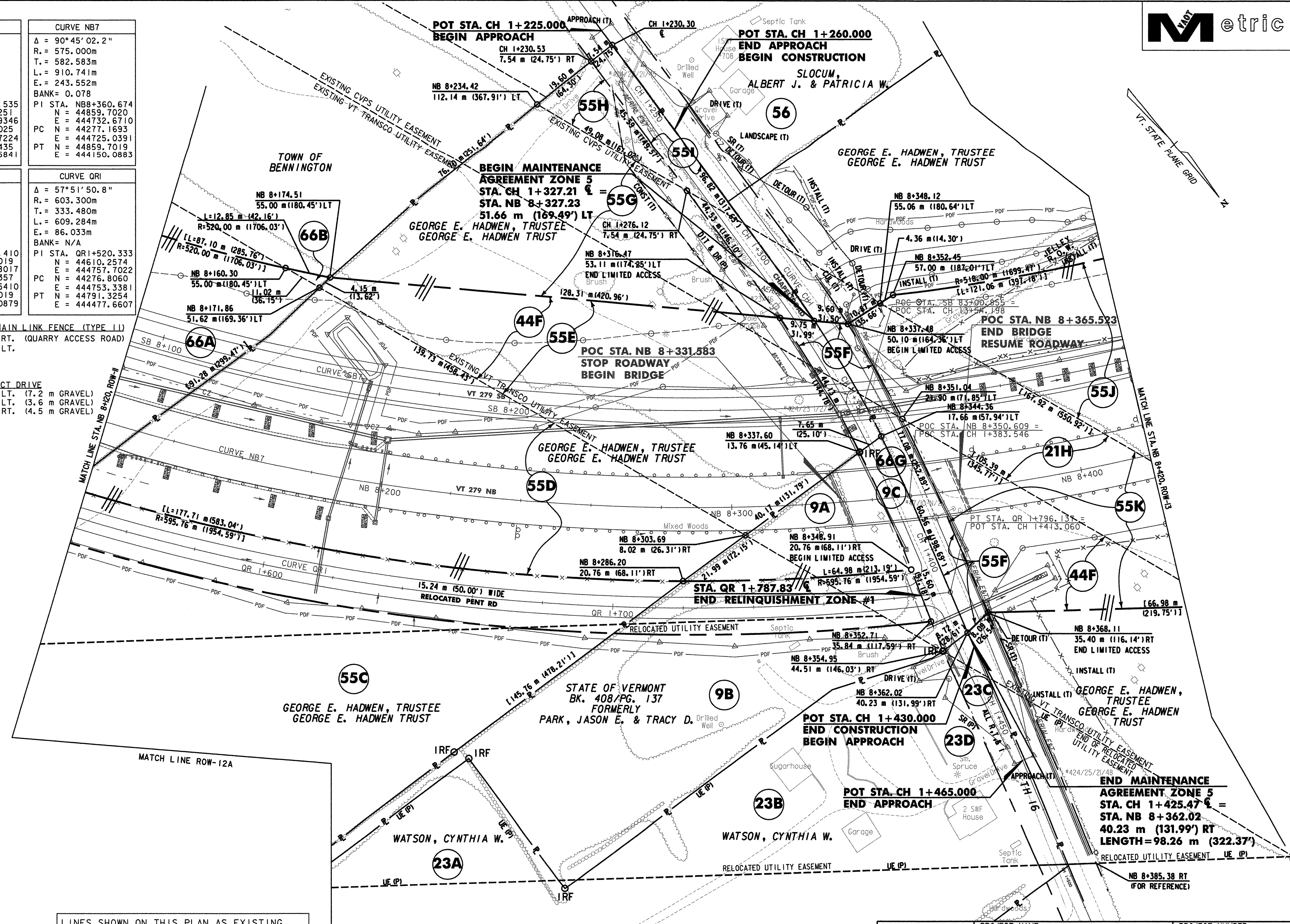

| DATUM | |
|------------|---------------|
| VERTICAL | NAVD 88 |
| HORIZONTAL | NAD 83 (1992) |

LINES SHOWN ON THIS PLAN AS EXISTING PROPERTY LINES P/L ARE BELIEVED TO BE ACCURATE BUT SHOULD NOT BE RELIED UPON FOR PURPOSES UNRELATED TO THE STATE OF VERMONT'S ACQUISITION OF LAND AND RIGHTS FOR THIS PROJECT.

THIS SHEET TO BE USED FOR RIGHT-OF-WAY INFORMATION ONLY

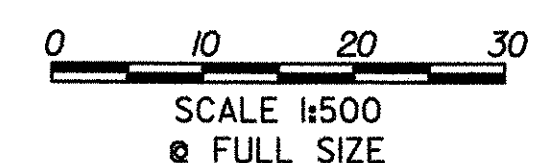

R.O.W. PLAN
ROW-12

| PROJECT NAME: | PROJECT NUMBER: |
|---|--------------------|
| BENNINGTON BYPASS | NH FO19-1(5) |
| DESIGN FILE NAME: c:\ndh\bennington\row | PLOT DATE: 3-26-07 |
| PROJECT LEADER: JDP | DRAWN BY: MBB |
| | CHECKED BY: GAK |
| | SHEET: 82 OF 112 |

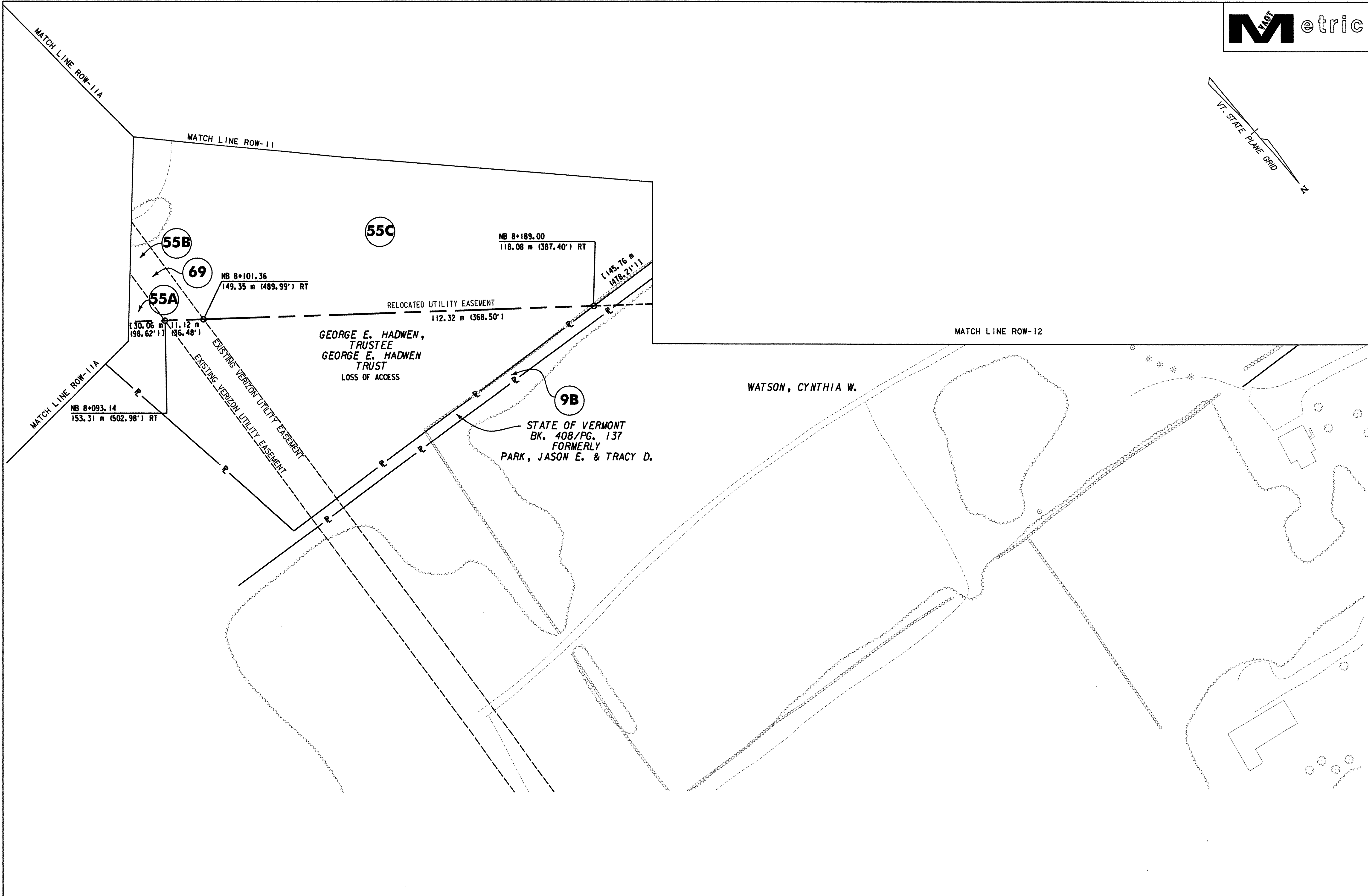
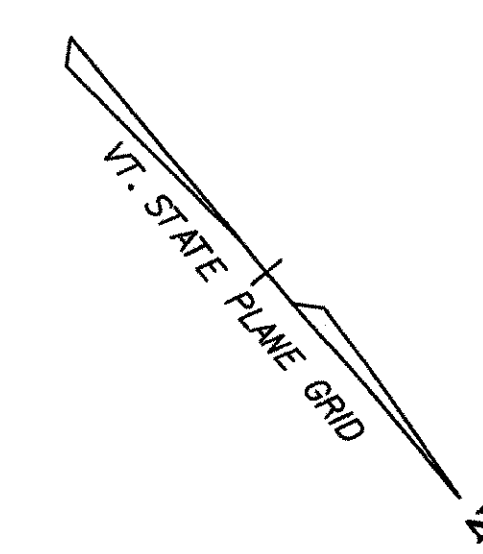

DATUM
 VERTICAL NAVD 88
 HORIZONTAL NAD 83 (1992)

LINES SHOWN ON THIS PLAN AS EXISTING PROPERTY LINES P/L ARE BELIEVED TO BE ACCURATE BUT SHOULD NOT BE RELIED UPON FOR PURPOSES UNRELATED TO THE STATE OF VERMONT'S ACQUISITION OF LAND AND RIGHTS FOR THIS PROJECT.

THIS SHEET TO BE USED FOR RIGHT-OF-WAY INFORMATION ONLY

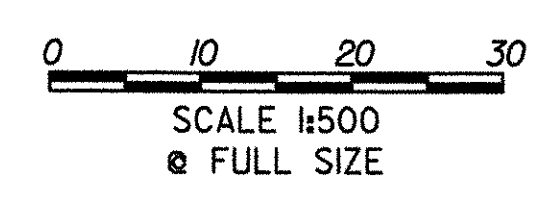

| | | |
|------------------------------------|--|----------------------------------|
| R.O.W. PLAN ROW-12A | PROJECT NAME: BENNINGTON BYPASS | PROJECT NUMBER: NH FO19-1(5) |
| | DESIGN FILE NAME: c:\dh\bennington\row | PLOT DATE: 3-26-07 |
| | PROJECT LEADER: JDP | DRAWN BY: MBB CHECKED BY: GAK |
| SHEET: 83 OF 112 | | |

CONSTRUCT DRIVE
 STA. NB 8+457.0 - NB 8+475.0 LT. (4.8 m GRAVEL)
 STA. NB 8+475.0 - NB 8+477.0 LT. (4.8 m GRAVEL)

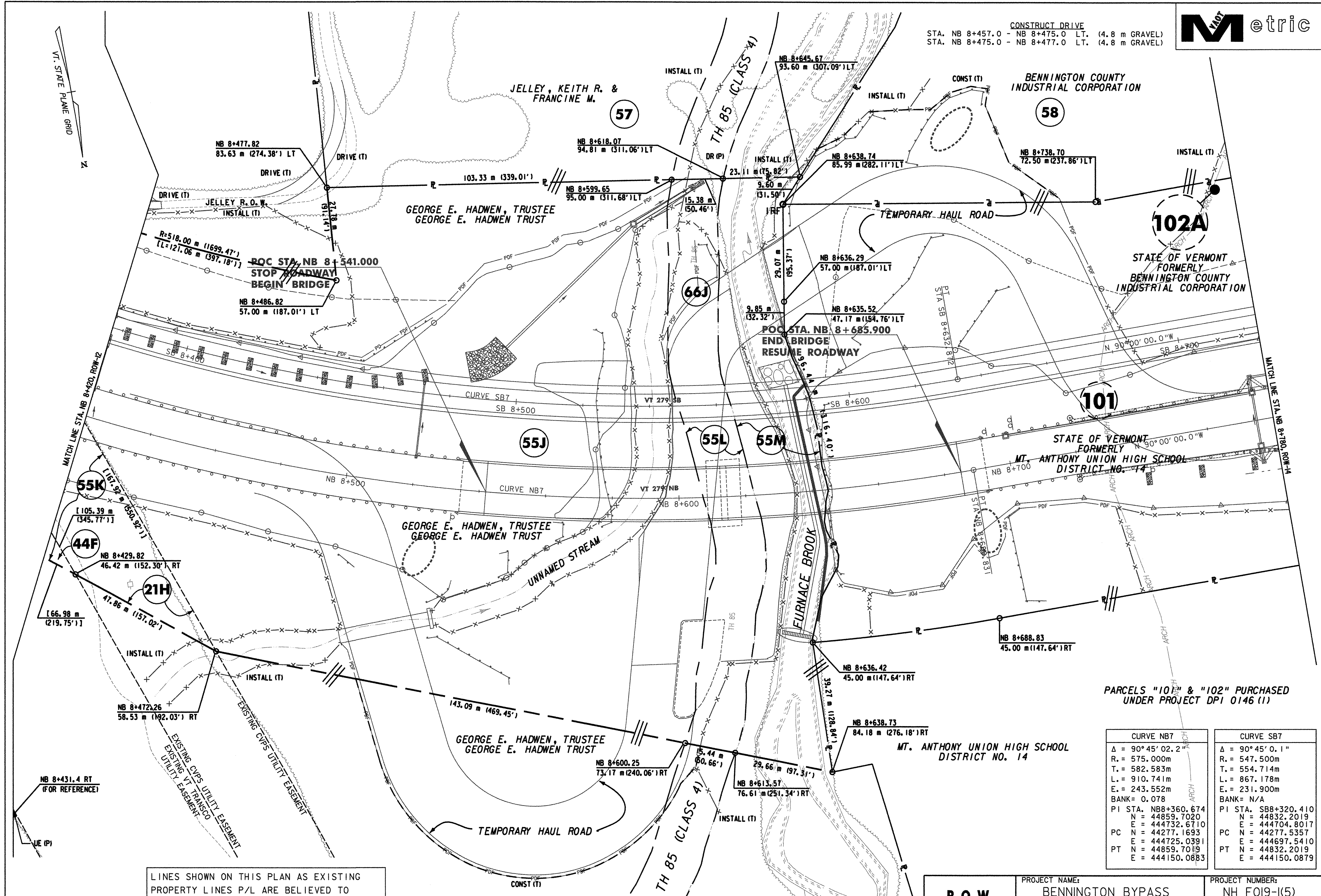

LINES SHOWN ON THIS PLAN AS EXISTING PROPERTY LINES P/L ARE BELIEVED TO BE ACCURATE BUT SHOULD NOT BE RELIED UPON FOR PURPOSES UNRELATED TO THE STATE OF VERMONT'S ACQUISITION OF LAND AND RIGHTS FOR THIS PROJECT.

THIS SHEET TO BE USED FOR RIGHT-OF-WAY INFORMATION ONLY

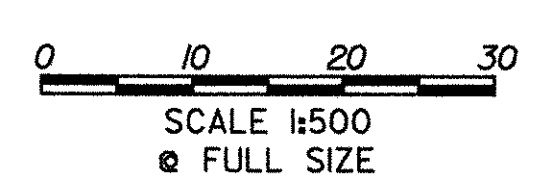

| CURVE NB7 | CURVE SB7 |
|--------------------------------|-------------------------------|
| $\Delta = 90^\circ 45' 02.2''$ | $\Delta = 90^\circ 45' 0.1''$ |
| R. = 575.000m | R. = 547.500m |
| T. = 582.583m | T. = 554.714m |
| L. = 910.741m | L. = 867.178m |
| E. = 243.552m | E. = 231.900m |
| BANK = 0.078 | BANK = N/A |
| PI STA. NB8+360.674 | PI STA. SB8+320.410 |
| N = 44859.7020 | N = 44832.2019 |
| E = 444732.6710 | E = 444704.8017 |
| PC N = 44277.1693 | PC N = 44277.5357 |
| E = 444725.0391 | E = 444697.5410 |
| PT N = 44859.7019 | PT N = 44832.2019 |
| E = 444150.0883 | E = 444150.0879 |

R.O.W. PLAN
ROW-13

PROJECT NAME: BENNINGTON BYPASS
 DESIGN FILE NAME: c:\dh\bennington\row
 PROJECT LEADER: JDP

PROJECT NUMBER: NH FO19-1(K5)
 PLOT DATE: 3-26-07
 DRAWN BY: MBB
 CHECKED BY: GAK

SHEET: 84 OF 112

DATUM
 VERTICAL NAVD 88
 HORIZONTAL NAD 83 (1992)

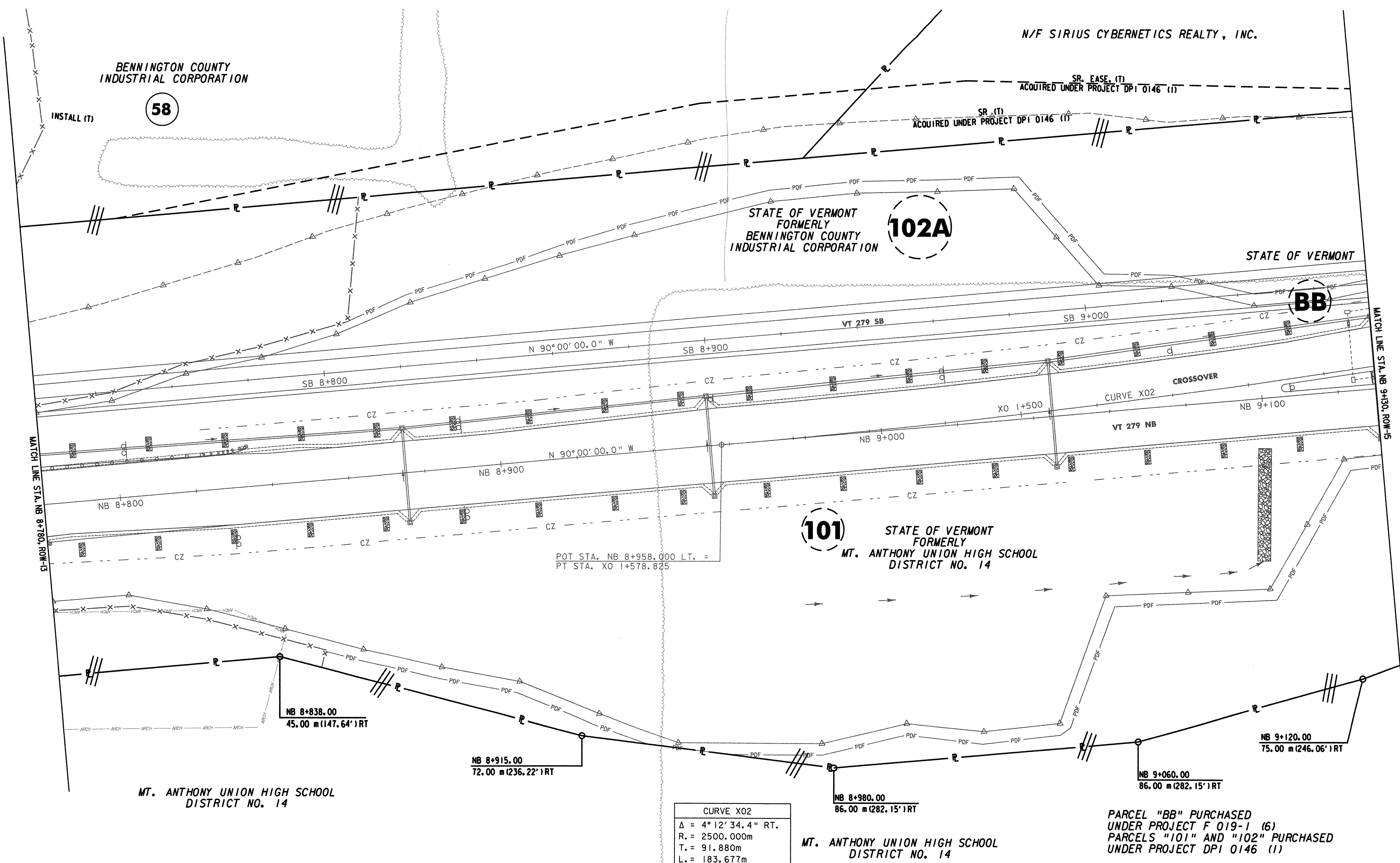
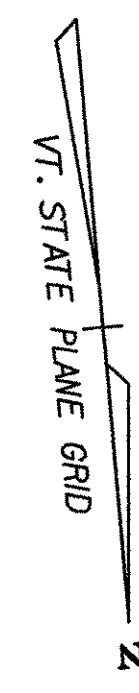

BENNINGTON COUNTY INDUSTRIAL CORPORATION

58

STATE OF VERMONT FORMERLY BENNINGTON COUNTY INDUSTRIAL CORPORATION

102A

STATE OF VERMONT

BB

STATE OF VERMONT FORMERLY MT. ANTHONY UNION HIGH SCHOOL DISTRICT NO. 14

101

MT. ANTHONY UNION HIGH SCHOOL DISTRICT NO. 14

NB 8+838.00
45.00 m (147.64') RT

NB 8+915.00
72.00 m (236.22') RT

NB 8+980.00
86.00 m (282.15') RT

NB 9+060.00
86.00 m (282.15') RT

NB 9+120.00
75.00 m (246.06') RT

PARCEL "BB" PURCHASED UNDER PROJECT F 019-1 (6)
PARCELS "101" AND "102" PURCHASED UNDER PROJECT DPI 0146 (1)

| CURVE X02 | |
|-----------|--------------------|
| Δ | = 4° 12' 34.4" RT. |
| R. | = 2500.000m |
| T. | = 91.880m |
| L. | = 183.677m |
| E. | = 1.688m |
| BANK | = 0.021 |
| PI STA. | X01+487.027 |
| N | = 44859.7018 |
| E | = 443789.0399 |
| PC N | = 44852.9574 |
| E | = 443697.4078 |
| PT N | = 44859.7018 |
| E | = 443880.9198 |

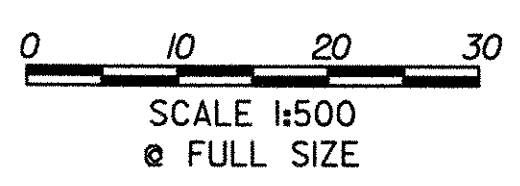

| | | |
|-----------------------------------|--|----------------------------------|
| R.O.W. PLAN ROW-14 | PROJECT NAME: BENNINGTON BYPASS | PROJECT NUMBER: NH F019-(K5) |
| | DESIGN FILE NAME: c:\dh\bennington\row | PLOT DATE: 1-30-06 |
| | PROJECT LEADER: JDP | DRAWN BY: MBB CHECKED BY: GAK |
| SHEET: 85 OF 112 | | |

LINES SHOWN ON THIS PLAN AS EXISTING PROPERTY LINES P/L ARE BELIEVED TO BE ACCURATE BUT SHOULD NOT BE RELIED UPON FOR PURPOSES UNRELATED TO THE STATE OF VERMONT'S ACQUISITION OF LAND AND RIGHTS FOR THIS PROJECT.

THIS SHEET TO BE USED FOR RIGHT-OF-WAY INFORMATION ONLY

| | |
|------------|---------------|
| DATUM | |
| VERTICAL | NAVD 88 |
| HORIZONTAL | NAD 83 (1992) |



| CURVE NB8 | CURVE X02 |
|-----------------------------------|-----------------------------------|
| $\Delta = 7^{\circ}15'00.0''$ RT. | $\Delta = 4^{\circ}12'34.4''$ RT. |
| R. = 2380.000m | R. = 2500.000m |
| T. = 150.780m | T. = 91.880m |
| L. = 301.157m | L. = 183.677m |
| E. = 4.771m | E. = 1.688m |
| BANK = 0.021 | BANK = 0.021 |
| PI STA. NB9+411.766 | PI STA. X01+487.027 |
| N = 44859.7018 | N = 44859.7018 |
| E = 443427.1540 | E = 443789.0399 |
| PC N = 44859.7018 | PC N = 44852.9574 |
| E = 443577.9337 | E = 443697.4078 |
| PT N = 44878.7300 | PT N = 44859.7018 |
| E = 443277.5798 | E = 443880.9198 |

| CURVE CD3 | CURVE X01 |
|------------------------------------|------------------------------------|
| $\Delta = 12^{\circ}01'40.6''$ LT. | $\Delta = 11^{\circ}27'34.4''$ RT. |
| R. = 395.000m | R. = 1595.000m |
| T. = 41.614m | T. = 160.040m |
| L. = 82.921m | L. = 317.012m |
| E. = 2.186m | E. = 8.009m |
| BANK = 0.000 | BANK = 0.021 |
| PI STA. CD2+304.767 | PI STA. X01+160.040 |
| N = 44824.4065 | N = 44835.6210 |
| E = 443375.0412 | E = 443461.8693 |
| PC N = 44829.6580 | PC N = 44855.8178 |
| E = 443333.7603 | E = 443303.1092 |
| PT N = 44827.8727 | PT N = 44847.3686 |
| E = 443416.5101 | E = 443621.4772 |

| CURVE ERI |
|------------------------------------|
| $\Delta = 16^{\circ}42'48.2''$ LT. |
| R. = 800.000m |
| T. = 117.516m |
| L. = 233.363m |
| E. = 8.585m |
| BANK = 0.000 |
| PI STA. ER 1+121.710 |
| N = 44784.9998 |
| E = 443552.3856 |
| PC N = 44677.5126 |
| E = 443504.8830 |
| PT N = 44901.6072 |
| E = 443566.9699 |

**R.O.W. PLAN
ROW-15**

PROJECT NAME:
BENNINGTON BYPASS

DESIGN FILE NAME: c:\dh\bennington\row

PROJECT LEADER: JDP

PROJECT NUMBER:
NH F019-1(K5)

PLOT DATE: 1-17-07
DRAWN BY: MBB
CHECKED BY: GAK

SHEET: **86** OF **112**

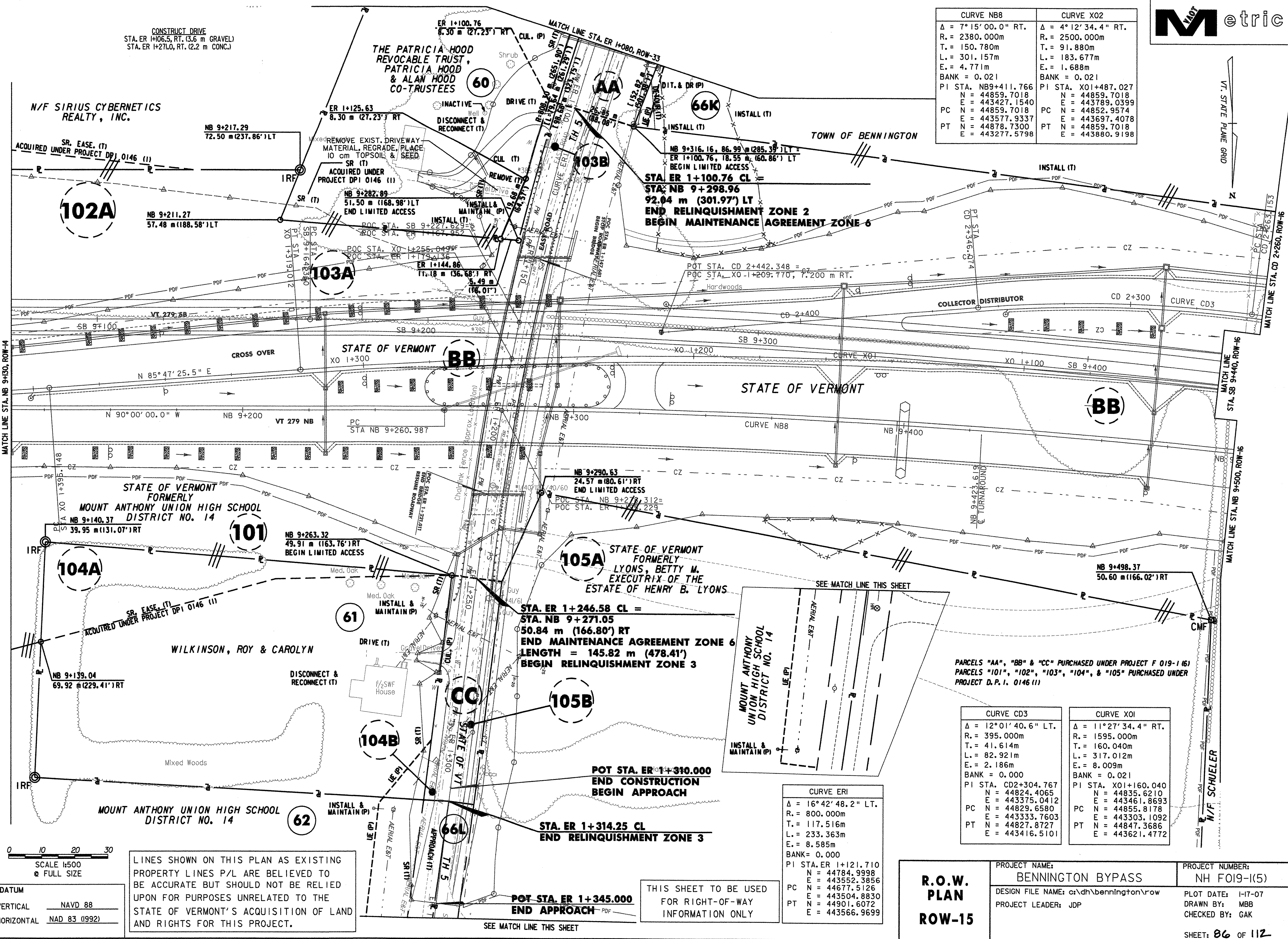

CONSTRUCT DRIVE
STA. ER 1+106.5, RT. (3.6 m GRAVEL)
STA. ER 1+271.0, RT. (2.2 m CONC.)

N/F SIRIUS CYBERNETICS
REALTY, INC.

THE PATRICIA HOOD
REVOCABLE TRUST,
PATRICIA HOOD
& ALAN HOOD
CO-TRUSTEES

TOWN OF BENNINGTON

STATE OF VERMONT

STATE OF VERMONT

STATE OF VERMONT
FORMERLY
MOUNT ANTHONY UNION HIGH SCHOOL
DISTRICT NO. 14

STATE OF VERMONT
FORMERLY
LYONS, BETTY M.
EXECUTRIX OF THE
ESTATE OF HENRY B. LYONS

WILKINSON, ROY & CAROLYN

MOUNT ANTHONY UNION HIGH SCHOOL
DISTRICT NO. 14

SCALE 1:500
FULL SIZE

LINES SHOWN ON THIS PLAN AS EXISTING
PROPERTY LINES P/L ARE BELIEVED TO
BE ACCURATE BUT SHOULD NOT BE RELIED
UPON FOR PURPOSES UNRELATED TO THE
STATE OF VERMONT'S ACQUISITION OF LAND
AND RIGHTS FOR THIS PROJECT.

DATUM
VERTICAL NAVD 88
HORIZONTAL NAD 83 (1992)

THIS SHEET TO BE USED
FOR RIGHT-OF-WAY
INFORMATION ONLY

SEE MATCH LINE THIS SHEET

| CURVE NB8 | CURVE EI | CURVE NI | CURVE XO1 |
|--|---|--|---|
| $\Delta = 7^{\circ}15'00.0''$ RT. R. = 2380.000m T. = 150.780m L. = 301.157m E. = 4.771m BANK = 0.021 PI STA. NB9+411.767 N = 44859.7018 E = 443427.1540 PC N = 44859.7018 E = 443577.9337 PT N = 44878.7300 E = 443277.5798 | $\Delta = 47^{\circ}02'33.6''$ RT. R. = 340.000m T. = 147.987m L. = 276.157m E. = 30.810m BANK = 0.060 PI STA EI+152.477 N = 44931.1345 E = 442951.2506 PC N = 44912.4568 E = 443098.0539 PT N = 45051.3022 E = 442864.8804 | $\Delta = 93^{\circ}41'00.4''$ RT. R. = 318.482m T. = 339.644m L. = 520.745m E. = 147.124m BANK = 0.060 PI STA NI+339.644 N = 44878.5329 E = 442883.0050 PC N = 44539.5464 E = 442861.8761 PT N = 44835.6697 E = 443219.9338 | $\Delta = 4^{\circ}12'34.4''$ RT. R. = 2500.000m T. = 91.880m L. = 183.677m E. = 1.688m BANK = 0.000 PI STA XO 1+487.027 N = 44859.7018 E = 443789.0399 PC N = 44852.9574 E = 443697.4078 PT N = 44859.7018 E = 443880.9198 |

TOWN OF BENNINGTON

66K

VT STATE PLANE GRID

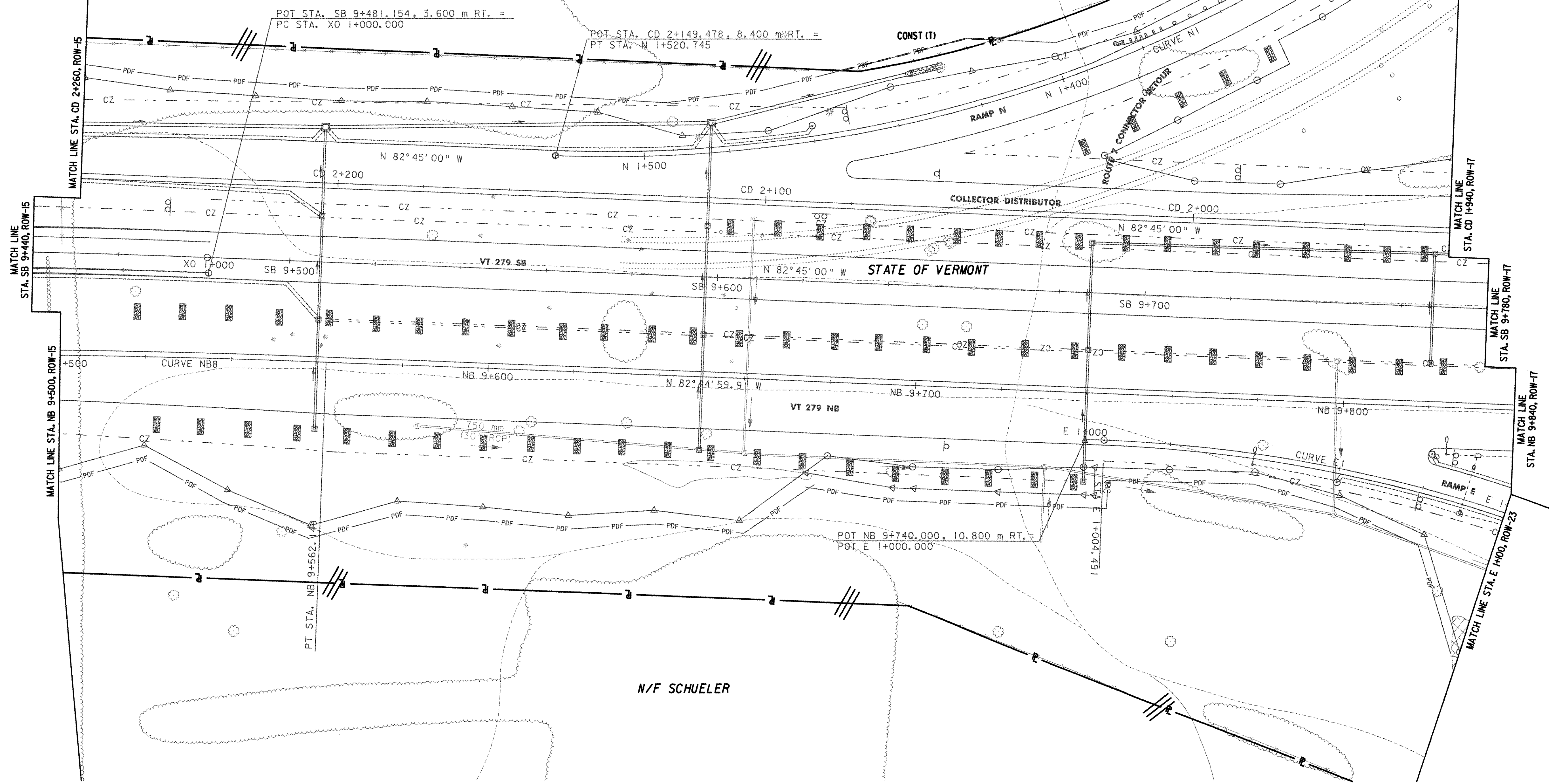

LINES SHOWN ON THIS PLAN AS EXISTING PROPERTY LINES P/L ARE BELIEVED TO BE ACCURATE BUT SHOULD NOT BE RELIED UPON FOR PURPOSES UNRELATED TO THE STATE OF VERMONT'S ACQUISITION OF LAND AND RIGHTS FOR THIS PROJECT.

THIS SHEET TO BE USED FOR RIGHT-OF-WAY INFORMATION ONLY

DATUM
VERTICAL NAVD 88
HORIZONTAL NAD 83 (1992)

0 10 20 30
SCALE 1:500
@ FULL SIZE

R.O.W. PLAN
ROW-16

PROJECT NAME: BENNINGTON BYPASS
DESIGN FILE NAME: c:\dh\bennington\row
PROJECT LEADER: JDP

PROJECT NUMBER: NH FO19-1(5)
PLOT DATE: 12-06-05
DRAWN BY: MBB
CHECKED BY: GAK
SHEET: 87 OF 112

TOWN OF BENNINGTON

66K

BENNINGTON SCHOOL DISTRICT INC.

65

| CURVE CNI | |
|-----------|----------------|
| Δ | = 91°05'41.6" |
| R. | = 465.700m |
| T. | = 474.685 |
| L. | = 740.419m |
| E. | = 199.283 |
| BANK | = 0.069 |
| Ls | = 61.000m |
| θ | = 03°45'08.9" |
| Ts | = 572.307m |
| Lt | = 40.676m |
| St | = 20.342m |
| PI STA. | CN2+187.328 |
| N | = 45343.9089 |
| E | = 442869.5951 |
| TS | N = 44808.2875 |
| E | = 442868.6700 |
| SC | N = 44869.2261 |
| E | = 442871.1345 |
| CS | N = 45333.2994 |
| E | = 442395.0283 |
| ST | N = 45329.2762 |
| E | = 442334.1728 |

| CURVE FI | |
|----------|--------------------|
| Δ | = 242°12'47.6" RT. |
| R. | = 55.000m |
| T. | = N/A |
| L. | = 232.508m |
| E. | = N/A |
| BANK | = 0.060 |
| PC N | = 44961.0456 |
| E | = 442541.0127 |
| PT N | = 45035.4530 |
| E | = 442828.9462 |

| CURVE KI | |
|----------|-------------------|
| Δ | = 79°07'24.3" RT. |
| R. | = 400.000m |
| T. | = 330.459 |
| L. | = 552.386m |
| E. | = 118.848 |
| BANK | = 0.060 |
| PI STA. | N1+330.459 |
| N | = 44845.4016 |
| E | = 442861.0274 |
| PC | N = 44927.8249 |
| E | = 442541.0127 |
| PT | N = 44515.5828 |
| E | = 442840.4696 |

| CURVE LI | |
|----------|--------------------|
| Δ | = 274°03'49.1" LT. |
| R. | = 55.000m |
| T. | = N/A |
| L. | = 263.082m |
| E. | = N/A |
| BANK | = 0.060 |
| PC N | = 44831.1487 |
| E | = 442860.0699 |
| PT N | = 44888.7677 |
| E | = 442812.0978 |

| CURVE MI | |
|----------|--------------------|
| Δ | = 266°08'11.5" RT. |
| R. | = 55.000m |
| T. | = N/A |
| L. | = 255.473m |
| E. | = N/A |
| BANK | = 0.060 |
| PC N | = 44872.3329 |
| E | = 442941.2524 |
| PT N | = 44821.0215 |
| E | = 442879.4076 |

| CURVE NI | |
|----------|-------------------|
| Δ | = 93°41'00.4" RT. |
| R. | = 318.482m |
| T. | = 339.644m |
| L. | = 520.745m |
| E. | = 147.124m |
| BANK | = 0.060 |
| PI STA. | N1+339.644 |
| N | = 44878.5329 |
| E | = 442883.0050 |
| PC | N = 44539.5464 |
| E | = 442861.8761 |
| PT | N = 44835.6697 |
| E | = 443219.9338 |

LINES SHOWN ON THIS PLAN AS EXISTING PROPERTY LINES P/L ARE BELIEVED TO BE ACCURATE BUT SHOULD NOT BE RELIED UPON FOR PURPOSES UNRELATED TO THE STATE OF VERMONT'S ACQUISITION OF LAND AND RIGHTS FOR THIS PROJECT.

THIS SHEET TO BE USED FOR RIGHT-OF-WAY INFORMATION ONLY

| | |
|------------|---------------|
| DATUM | |
| VERTICAL | NAVD 88 |
| HORIZONTAL | NAD 83 (1992) |

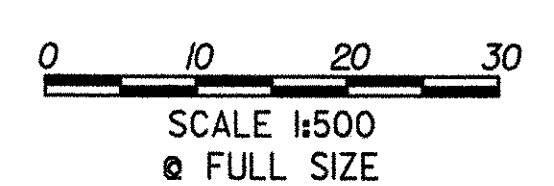

| | | |
|-----------------------------------|--|----------------------------------|
| R.O.W. PLAN ROW-17 | PROJECT NAME: BENNINGTON BYPASS | PROJECT NUMBER: NH F019-1(5) |
| | DESIGN FILE NAME: c:\dh\bennington\row | PLOT DATE: 3-26-07 |
| | PROJECT LEADER: JDP | DRAWN BY: MBB CHECKED BY: GAK |
| | | SHEET: 88 OF 112 |

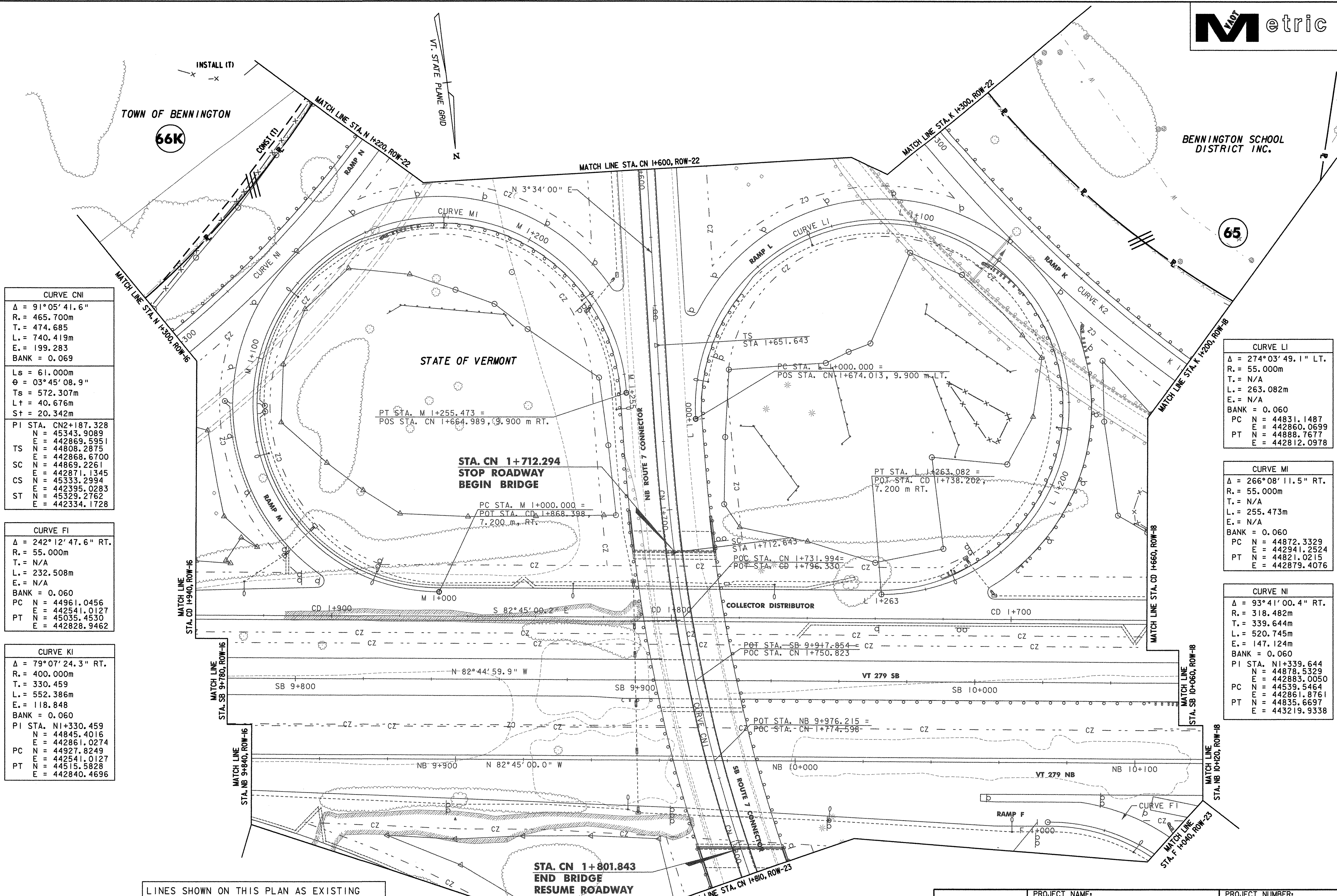

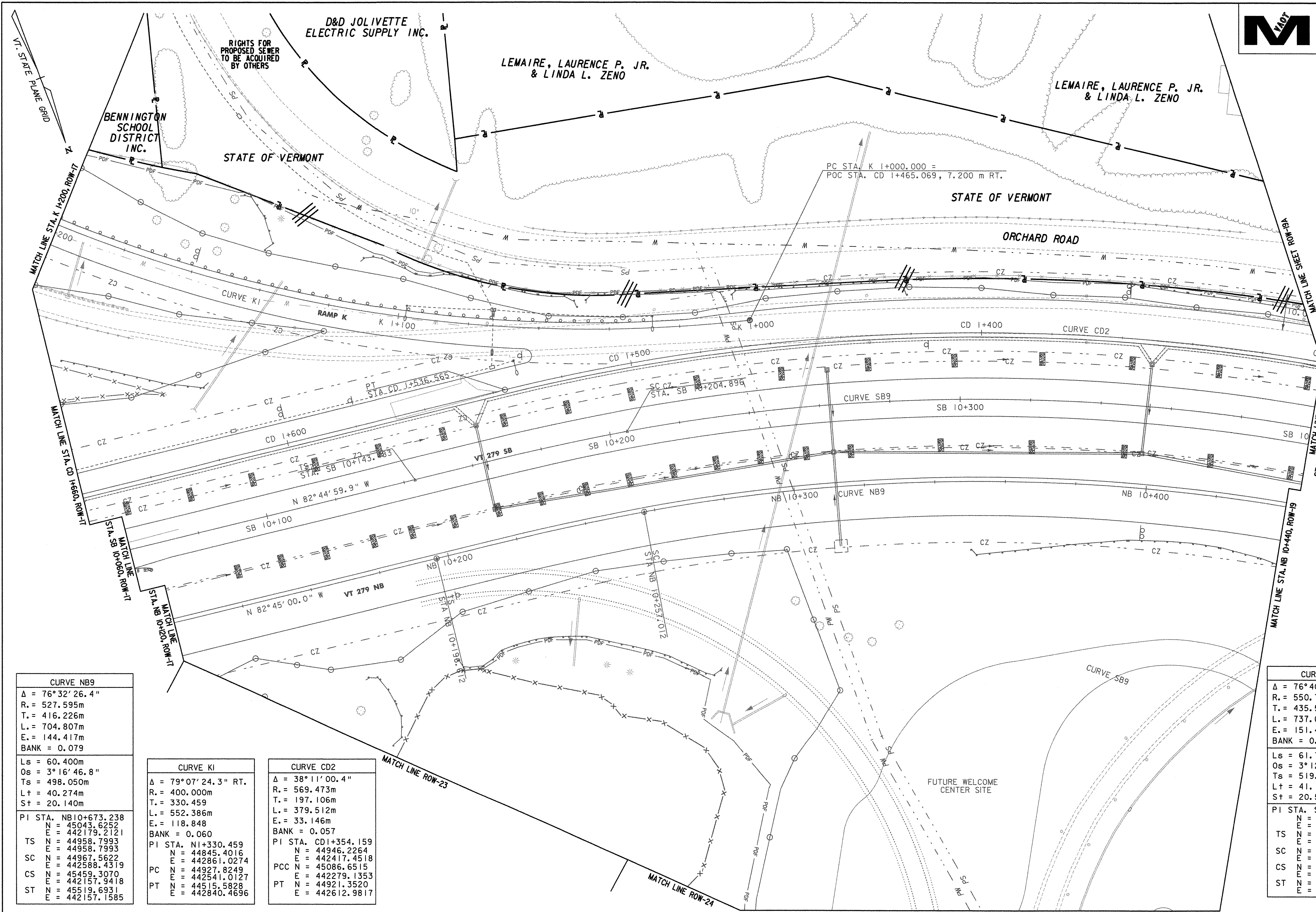

| CURVE NB9 | |
|-----------|-----------------|
| Δ | = 76° 32' 26.4" |
| R. | = 527.595m |
| T. | = 416.226m |
| L. | = 704.807m |
| E. | = 144.417m |
| BANK | = 0.079 |
| Ls | = 60.400m |
| Os | = 3° 16' 46.8" |
| Ts | = 498.050m |
| Lt | = 40.274m |
| St | = 20.140m |
| PI STA. | NB10+673.238 |
| N | = 45043.6252 |
| E | = 442179.2121 |
| TS | N = 44958.7993 |
| E | = 44958.7993 |
| SC | N = 44967.5622 |
| E | = 442588.4319 |
| CS | N = 45459.3070 |
| E | = 442157.9418 |
| ST | N = 45519.6931 |
| E | = 442157.1585 |

| CURVE KI | |
|----------|---------------------|
| Δ | = 79° 07' 24.3" RT. |
| R. | = 400.000m |
| T. | = 330.459 |
| L. | = 552.386m |
| E. | = 118.848 |
| BANK | = 0.060 |
| PI STA. | NI+330.459 |
| N | = 44845.4016 |
| E | = 442861.0274 |
| PC | N = 44927.8249 |
| E | = 442541.0127 |
| PT | N = 44515.5828 |
| E | = 442840.4696 |

| CURVE CD2 | |
|-----------|-----------------|
| Δ | = 38° 11' 00.4" |
| R. | = 569.473m |
| T. | = 197.106m |
| L. | = 379.512m |
| E. | = 33.146m |
| BANK | = 0.057 |
| PI STA. | CDI+354.159 |
| N | = 44946.2264 |
| E | = 442417.4518 |
| PCC | N = 45086.6515 |
| E | = 442279.1353 |
| PT | N = 44921.3520 |
| E | = 442612.9817 |

| CURVE SB9 | |
|-----------|-----------------|
| Δ | = 76° 40' 45.2" |
| R. | = 550.702m |
| T. | = 435.537m |
| L. | = 737.007m |
| E. | = 151.413m |
| BANK | = 0.079 |
| Ls | = 61.713m |
| Os | = 3° 12' 37.3" |
| Ts | = 519.185m |
| Lt | = 41.149m |
| St | = 20.577m |
| PI STA. | SB10+640.432 |
| N | = 45023.7967 |
| E | = 442156.5660 |
| TS | N = 44935.7938 |
| E | = 442645.9195 |
| SC | N = 44944.7226 |
| E | = 4425844.8645 |
| CS | N = 45458.7909 |
| E | = 442134.8315 |
| ST | N = 45520.4904 |
| E | = 442134.0560 |

LINES SHOWN ON THIS PLAN AS EXISTING PROPERTY LINES P/L ARE BELIEVED TO BE ACCURATE BUT SHOULD NOT BE RELIED UPON FOR PURPOSES UNRELATED TO THE STATE OF VERMONT'S ACQUISITION OF LAND AND RIGHTS FOR THIS PROJECT.

THIS SHEET TO BE USED FOR RIGHT-OF-WAY INFORMATION ONLY

| | |
|------------|---------------|
| DATUM | |
| VERTICAL | NAVD 88 |
| HORIZONTAL | NAD 83 (1992) |

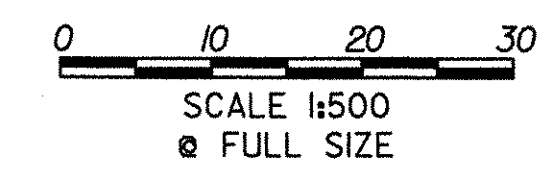

| | | |
|-----------------------------------|--|----------------------------------|
| R.O.W. PLAN ROW-18 | PROJECT NAME: BENNINGTON BYPASS | PROJECT NUMBER: NH F019-1(5) |
| | DESIGN FILE NAME: c:\dh\bennington\row | PLOT DATE: 12-06-05 |
| | PROJECT LEADER: JDP | DRAWN BY: MBB CHECKED BY: GAK |
| | | SHEET: 89 OF 112 |

| CURVE G1 | |
|----------------------|--|
| Δ = 236°03'34.7" RT. | |
| R. = 90.000m | |
| T. = N/A | |
| L. = 370.802m | |
| E. = N/A | |
| BANK = 0.060 | |
| PI STA. G1+396.514 | |
| N = 45179.3415 | |
| E = 442268.2761 | |
| PC N = 45305.8601 | |
| E = 442346.1949 | |
| PCC N = 45159.4245 | |
| E = 442284.5381 | |
| PT N = 45200.7744 | |
| E = 442254.0714 | |

| CURVE NB9 | |
|----------------------|--|
| Δ = 76°32'26.4" | |
| R. = 527.595m | |
| T. = 416.226m | |
| L. = 704.807m | |
| E. = 144.417m | |
| BANK = 0.079 | |
| Ls = 60.400m | |
| Os = 3°16'46.8" | |
| Ts = 498.050m | |
| Lt = 40.274m | |
| St = 20.140m | |
| PI STA. NB10+673.238 | |
| NZ = 45043.6252 | |
| EZ = 442179.2121 | |
| TS N = 44958.7993 | |
| EZ = 44958.7993 | |
| SC N = 44967.5622 | |
| EZ = 442588.4319 | |
| CS N = 45459.3070 | |
| EZ = 442157.9418 | |
| ST N = 45519.6931 | |
| EZ = 442157.1585 | |

| CURVE SB9 | |
|----------------------|--|
| Δ = 76°40'45.2" | |
| R. = 550.702m | |
| T. = 435.537m | |
| L. = 737.007m | |
| E. = 151.413m | |
| BANK = 0.079 | |
| Ls = 61.713m | |
| Os = 3°12'37.3" | |
| Ts = 519.185m | |
| Lt = 41.149m | |
| St = 20.577m | |
| PI STA. SB10+640.432 | |
| N = 45023.7967 | |
| E = 442156.5660 | |
| TS N = 44935.7938 | |
| E = 442645.9195 | |
| SC N = 44944.7226 | |
| E = 4425844.8645 | |
| CS N = 45458.7909 | |
| E = 442134.8315 | |
| ST N = 45520.4904 | |
| E = 442134.0560 | |

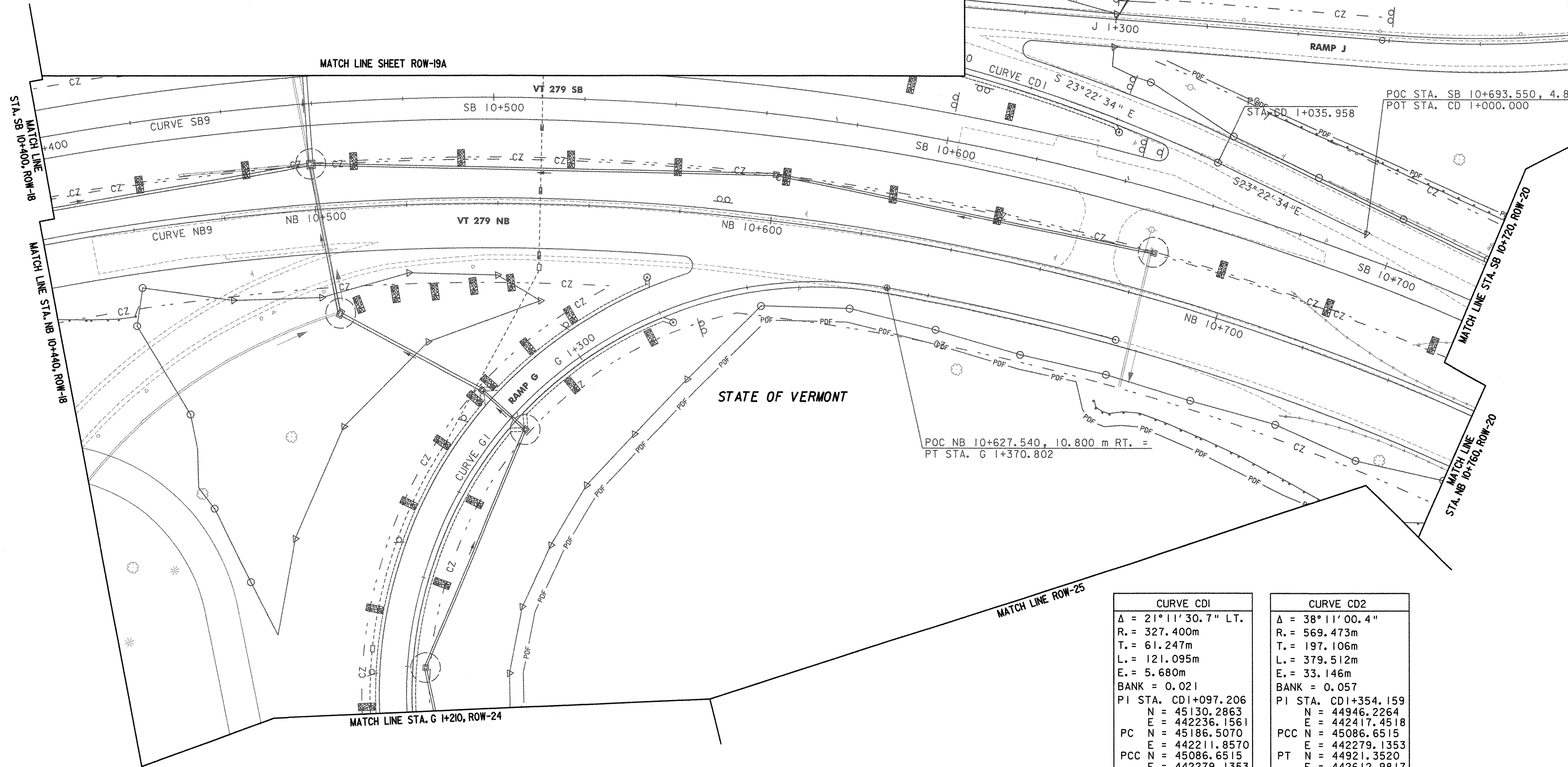
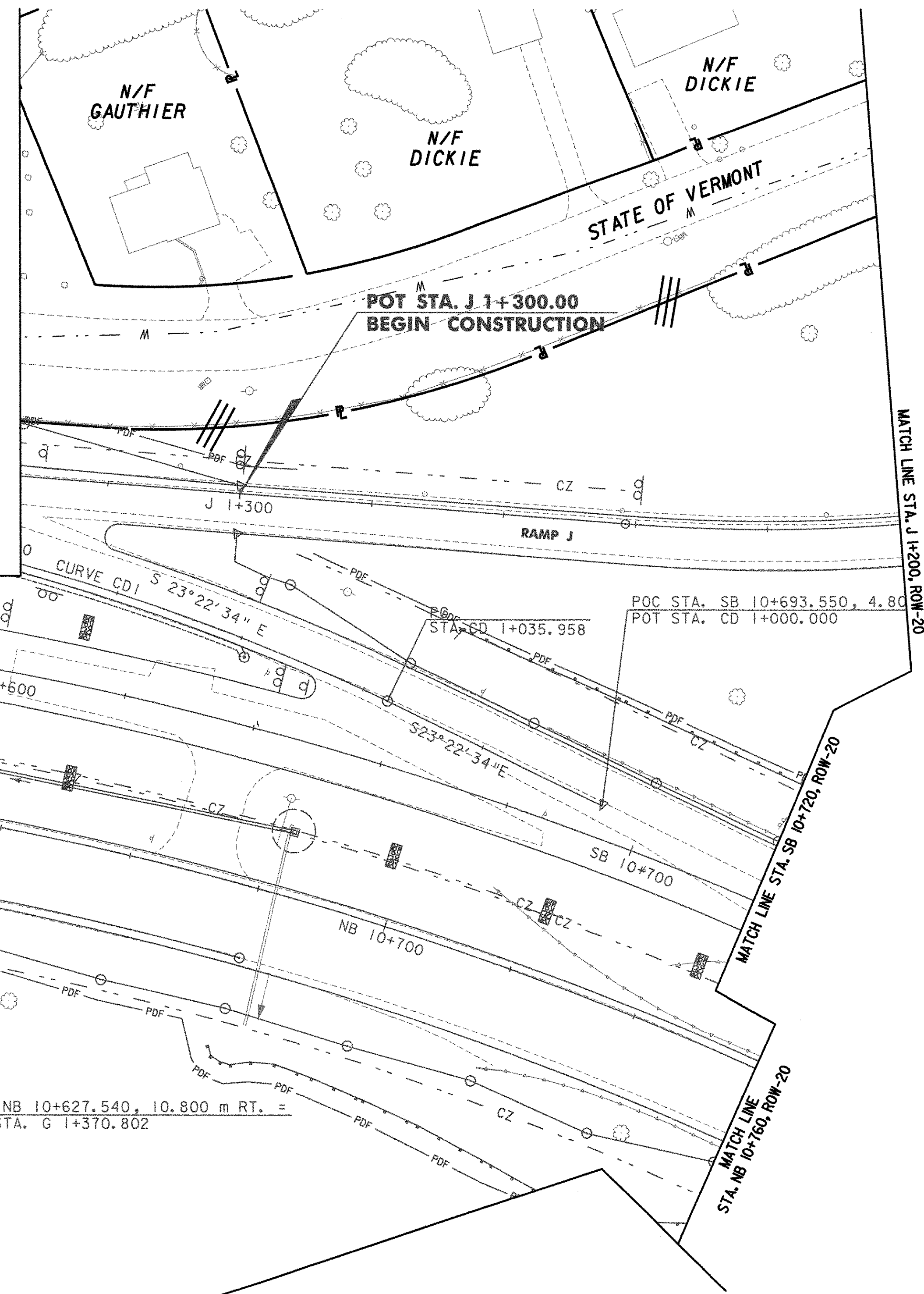
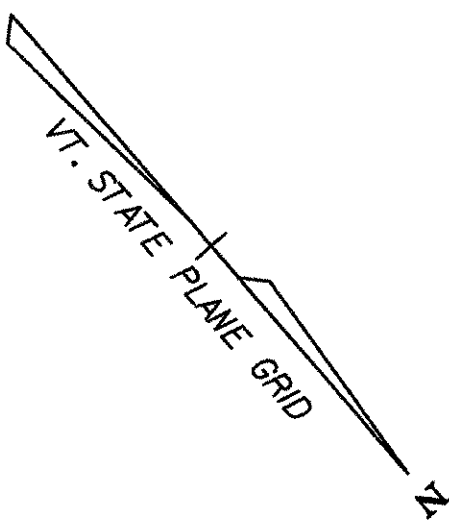

LINES SHOWN ON THIS PLAN AS EXISTING PROPERTY LINES P/L ARE BELIEVED TO BE ACCURATE BUT SHOULD NOT BE RELIED UPON FOR PURPOSES UNRELATED TO THE STATE OF VERMONT'S ACQUISITION OF LAND AND RIGHTS FOR THIS PROJECT.

THIS SHEET TO BE USED FOR RIGHT-OF-WAY INFORMATION ONLY

DATUM
 VERTICAL NAVD 88
 HORIZONTAL NAD 83 (1992)

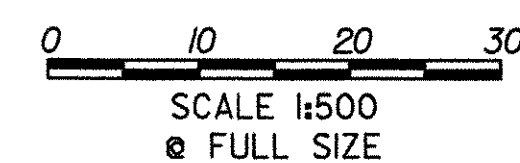

**R.O.W.
 PLAN
 ROW-19**

PROJECT NAME:
 BENNINGTON BYPASS
 DESIGN FILE NAME: c:\dh\bennington\row
 PROJECT LEADER: JDP

PROJECT NUMBER:
 NH FO19-1(5)
 PLOT DATE: 12-06-05
 DRAWN BY: MBB
 CHECKED BY: GAK
 SHEET: 90 OF 112

| CURVE CDI | |
|---------------------|--|
| Δ = 21°11'30.7" LT. | |
| R. = 327.400m | |
| T. = 61.247m | |
| L. = 121.095m | |
| E. = 5.680m | |
| BANK = 0.021 | |
| PI STA. CDI+097.206 | |
| N = 45130.2863 | |
| E = 442236.1561 | |
| PC N = 45186.5070 | |
| E = 442211.8570 | |
| PCC N = 45086.6515 | |
| E = 442279.1353 | |

| CURVE CD2 | |
|---------------------|--|
| Δ = 38°11'00.4" | |
| R. = 569.473m | |
| T. = 197.106m | |
| L. = 379.512m | |
| E. = 33.146m | |
| BANK = 0.057 | |
| PI STA. CD1+354.159 | |
| N = 44946.2264 | |
| E = 442417.4518 | |
| PCC N = 45086.6515 | |
| E = 442279.1353 | |
| PT N = 44921.3520 | |
| E = 442612.9817 | |

REMOVING AND RESETTING FENCE
STA DRN 20+055 - DRN 20+220 RT

GATE FOR CHAIN-LINK FENCE, 1.8 m (6 FEET)
STA DRN 20+117.6 - DRN 20+120.0 RT
STA DRN 20+120.0 - DRN 20+122.4 RT
STA DRN 20+177.6 - DRN 20+180.0 RT
STA DRN 20+180.0 - DRN 20+182.4 RT

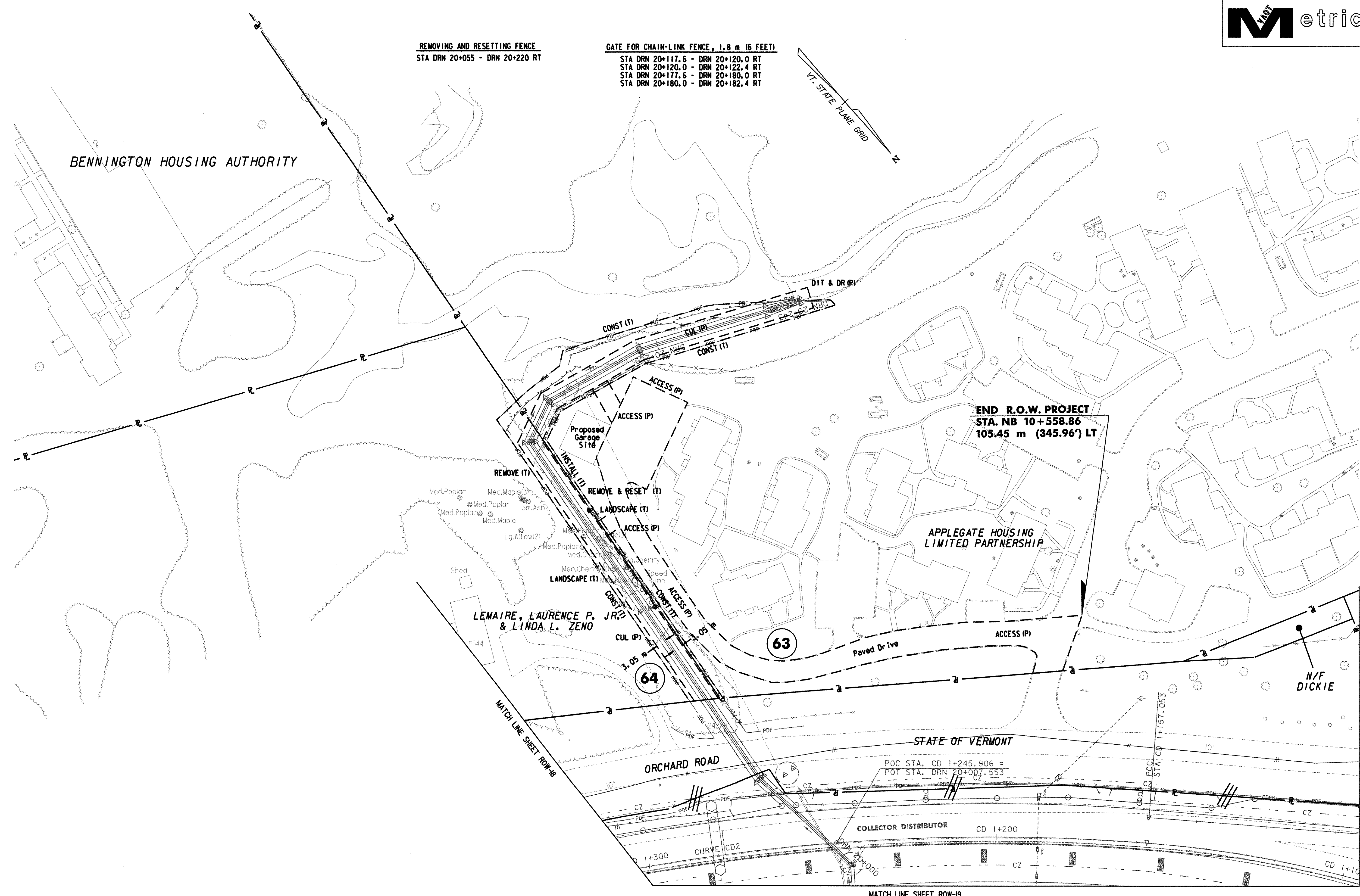
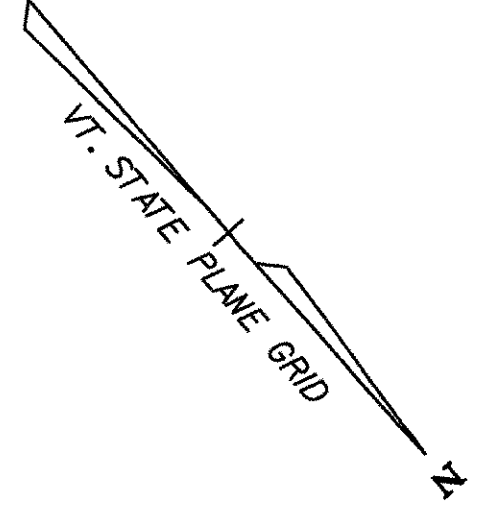

END R.O.W. PROJECT
STA. NB 10+558.86
105.45 m (345.96') LT

DATUM
VERTICAL NAVD 88
HORIZONTAL NAD 83 (1992)

LINES SHOWN ON THIS PLAN AS EXISTING PROPERTY LINES P/L ARE BELIEVED TO BE ACCURATE BUT SHOULD NOT BE RELIED UPON FOR PURPOSES UNRELATED TO THE STATE OF VERMONT'S ACQUISITION OF LAND AND RIGHTS FOR THIS PROJECT.

THIS SHEET TO BE USED FOR RIGHT-OF-WAY INFORMATION ONLY

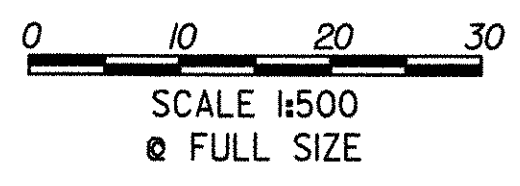

| | | |
|------------------------------------|--|----------------------------------|
| R.O.W. PLAN ROW-19A | PROJECT NAME: BENNINGTON BYPASS | PROJECT NUMBER: NH FO19-1(5) |
| | DESIGN FILE NAME: c:\dh\bennington\row | PLOT DATE: 1-30-06 |
| | PROJECT LEADER: JDP | DRAWN BY: MBB CHECKED BY: GAK |
| | | SHEET: 91 OF 112 |

VT. STATE PLANE GRID

N/F CATAMOUNT BROADCASTERS

N/F VAN NOSTRAND

N/F DICKIE

N/F SHULTZ

STATE OF VERMONT

STATE OF VERMONT

N/F VAN NOSTRAND

POC STA. NB 10+776
END PROJECT
NH F019-1(5)

POC STA. SB 10+758
END CONSTRUCTION

POT STA. R 1+280.000
BEGIN CONSTRUCTION

POC STA. NB 10+836
BEGIN APPROACH

POT STA. CN 2+660.000
END CONSTRUCTION

| CURVE HI | |
|----------|-------------------|
| Δ | = 93°31'06.3" RT. |
| R. | = 200.000m |
| T. | = 212.675m |
| L. | = 326.441m |
| E. | = 91.943m |
| BANK | = 0.060 |
| PI STA. | H1+212.675 |
| N | = 45330.8404 |
| E | = 442166.8007 |
| PC | N = 45342.5925 |
| E | = 442379.1505 |
| PT | N = 45543.5112 |
| E | = 442168.1025 |

| CURVE NB9 | |
|-----------|----------------|
| Δ | = 76°32'26.4" |
| R. | = 527.595m |
| T. | = 416.226m |
| L. | = 704.807m |
| E. | = 144.417m |
| BANK | = 0.079 |
| Ls | = 60.400m |
| Os | = 3°16'46.8" |
| Ts | = 498.050m |
| Lt | = 40.274m |
| St | = 20.140m |
| PI STA. | NB10+673.238 |
| N | = 45043.6252 |
| E | = 442179.2121 |
| TS | N = 44958.7993 |
| E | = 44958.7993 |
| SC | N = 44967.5622 |
| E | = 442588.4319 |
| CS | N = 45459.3070 |
| E | = 442157.9418 |
| ST | N = 45519.6931 |
| E | = 442157.1585 |

| CURVE SB9 | |
|-----------|----------------|
| Δ | = 76°40'45.2" |
| R. | = 550.702m |
| T. | = 435.537m |
| L. | = 737.007m |
| E. | = 151.413m |
| BANK | = 0.079 |
| Ls | = 61.713m |
| Os | = 3°12'37.3" |
| Ts | = 519.185m |
| Lt | = 41.149m |
| St | = 20.577m |
| PI STA. | SB10+640.432 |
| N | = 45023.7967 |
| E | = 442156.5660 |
| TS | N = 44935.7938 |
| E | = 442645.9195 |
| SC | N = 44944.7226 |
| E | = 4425844.8645 |
| CS | N = 45458.7909 |
| E | = 442134.8315 |
| ST | N = 45520.4904 |
| E | = 442134.0560 |

| DATUM | |
|------------|---------------|
| VERTICAL | NAVD 88 |
| HORIZONTAL | NAD 83 (1992) |

LINES SHOWN ON THIS PLAN AS EXISTING PROPERTY LINES P/L ARE BELIEVED TO BE ACCURATE BUT SHOULD NOT BE RELIED UPON FOR PURPOSES UNRELATED TO THE STATE OF VERMONT'S ACQUISITION OF LAND AND RIGHTS FOR THIS PROJECT.

THIS SHEET TO BE USED FOR RIGHT-OF-WAY INFORMATION ONLY

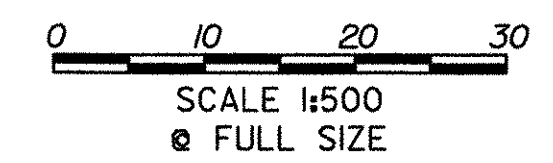

| | | |
|-----------------------------------|--|----------------------------------|
| R.O.W. PLAN ROW-20 | PROJECT NAME: BENNINGTON BYPASS | PROJECT NUMBER: NH F019-1(5) |
| | DESIGN FILE NAME: c:\dh\bennington\row | PLOT DATE: 12-06-05 |
| | PROJECT LEADER: JDP | DRAWN BY: MBB CHECKED BY: GAK |
| | | SHEET: 92 OF 112 |

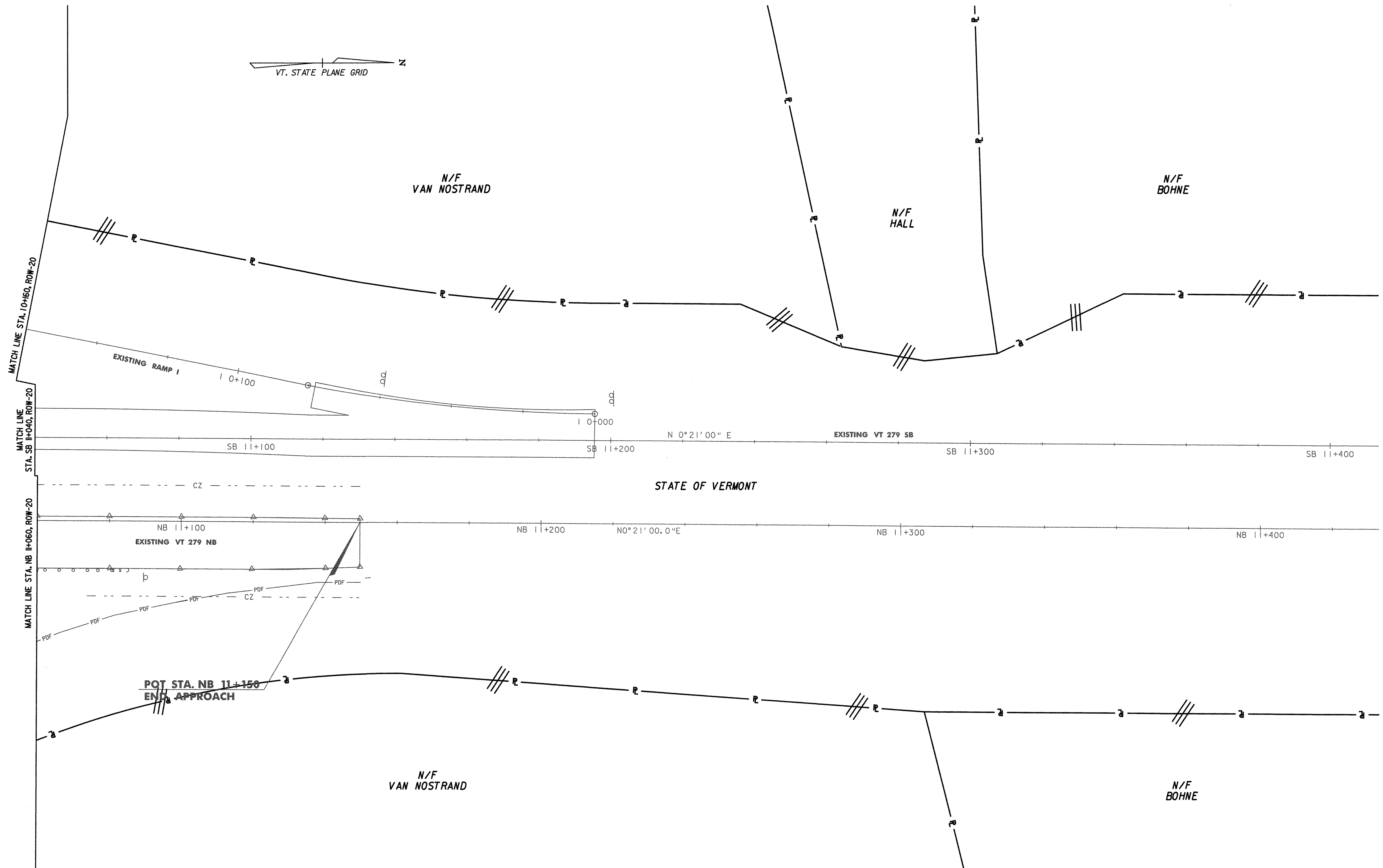

DATUM
 VERTICAL NAVD 88
 HORIZONTAL NAD 83 (1992)

LINES SHOWN ON THIS PLAN AS EXISTING PROPERTY LINES P/L ARE BELIEVED TO BE ACCURATE BUT SHOULD NOT BE RELIED UPON FOR PURPOSES UNRELATED TO THE STATE OF VERMONT'S ACQUISITION OF LAND AND RIGHTS FOR THIS PROJECT.

THIS SHEET TO BE USED FOR RIGHT-OF-WAY INFORMATION ONLY

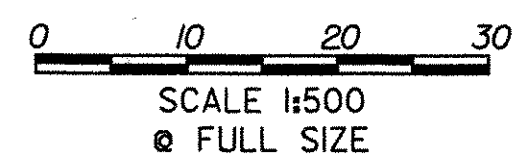

R.O.W. PLAN
ROW-21

PROJECT NAME: BENNINGTON BYPASS
 DESIGN FILE NAME: c:\dh\bennington\row
 PROJECT LEADER: JDP

PROJECT NUMBER: NH FO19-1(5)
 PLOT DATE: 12-06-05
 DRAWN BY: MBB
 CHECKED BY: GAK
 SHEET: 93 OF 112

VT. STATE PLANE GRID

BENNINGTON SCHOOL DISTRICT INC.

65

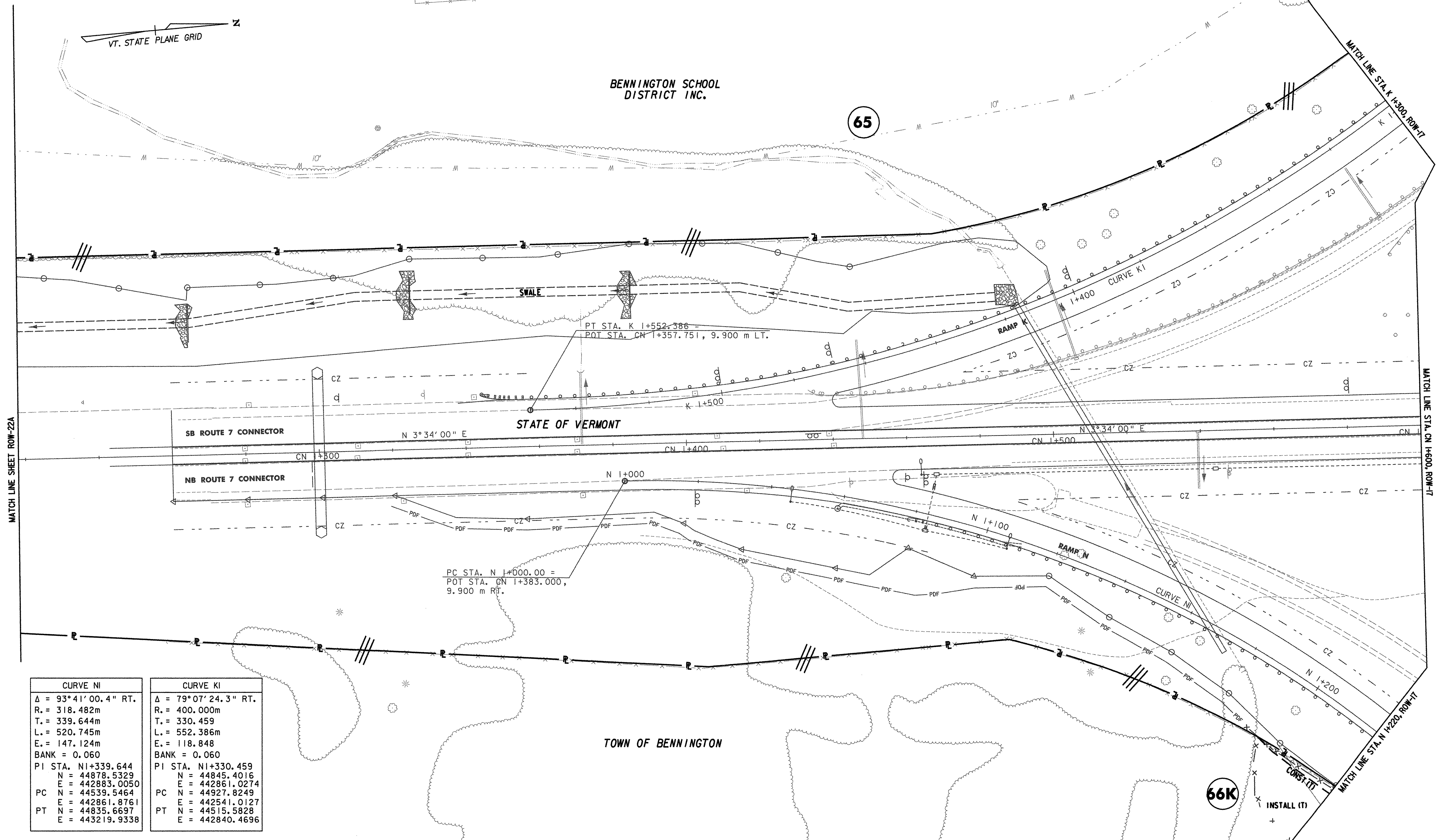

PT STA. K 1+552.386
POT STA. CN 1+357.751, 9.900 m LT.

PC STA. N 1+000.00 =
POT STA. CN 1+383.000,
9.900 m RT.

| CURVE NI | CURVE KI |
|------------------------------------|------------------------------------|
| $\Delta = 93^\circ 41' 00.4''$ RT. | $\Delta = 79^\circ 07' 24.3''$ RT. |
| R. = 318.482m | R. = 400.000m |
| T. = 339.644m | T. = 330.459 |
| L. = 520.745m | L. = 552.386m |
| E. = 147.124m | E. = 118.848 |
| BANK = 0.060 | BANK = 0.060 |
| PI STA. N1+339.644 | PI STA. N1+330.459 |
| N = 44878.5329 | N = 44845.4016 |
| E = 442883.0050 | E = 442861.0274 |
| PC N = 44539.5464 | PC N = 44927.8249 |
| E = 442861.8761 | E = 442541.0127 |
| PT N = 44835.6697 | PT N = 44515.5828 |
| E = 443219.9338 | E = 442840.4696 |

LINES SHOWN ON THIS PLAN AS EXISTING PROPERTY LINES P/L ARE BELIEVED TO BE ACCURATE BUT SHOULD NOT BE RELIED UPON FOR PURPOSES UNRELATED TO THE STATE OF VERMONT'S ACQUISITION OF LAND AND RIGHTS FOR THIS PROJECT.

THIS SHEET TO BE USED FOR RIGHT-OF-WAY INFORMATION ONLY

DATUM
VERTICAL NAVD 88
HORIZONTAL NAD 83 (1992)

0 10 20 30
SCALE 1:500
@ FULL SIZE

| | | |
|-------------------------------------|---|----------------------------------|
| R.O.W. PLAN ROW-22 | PROJECT NAME: BENNINGTON BYPASS | PROJECT NUMBER: NH F019-1(5) |
| | DESIGN FILE NAME: c:\ndh\bennington\row | PLOT DATE: 3-26-07 |
| | PROJECT LEADER: JDP | DRAWN BY: MBB CHECKED BY: GAK |
| SHEET: 94 OF 112 | | |



N/F FURNACE BROOK INVESTMENTS, LLC

BENNINGTON SCHOOL DISTRICT INC.

65

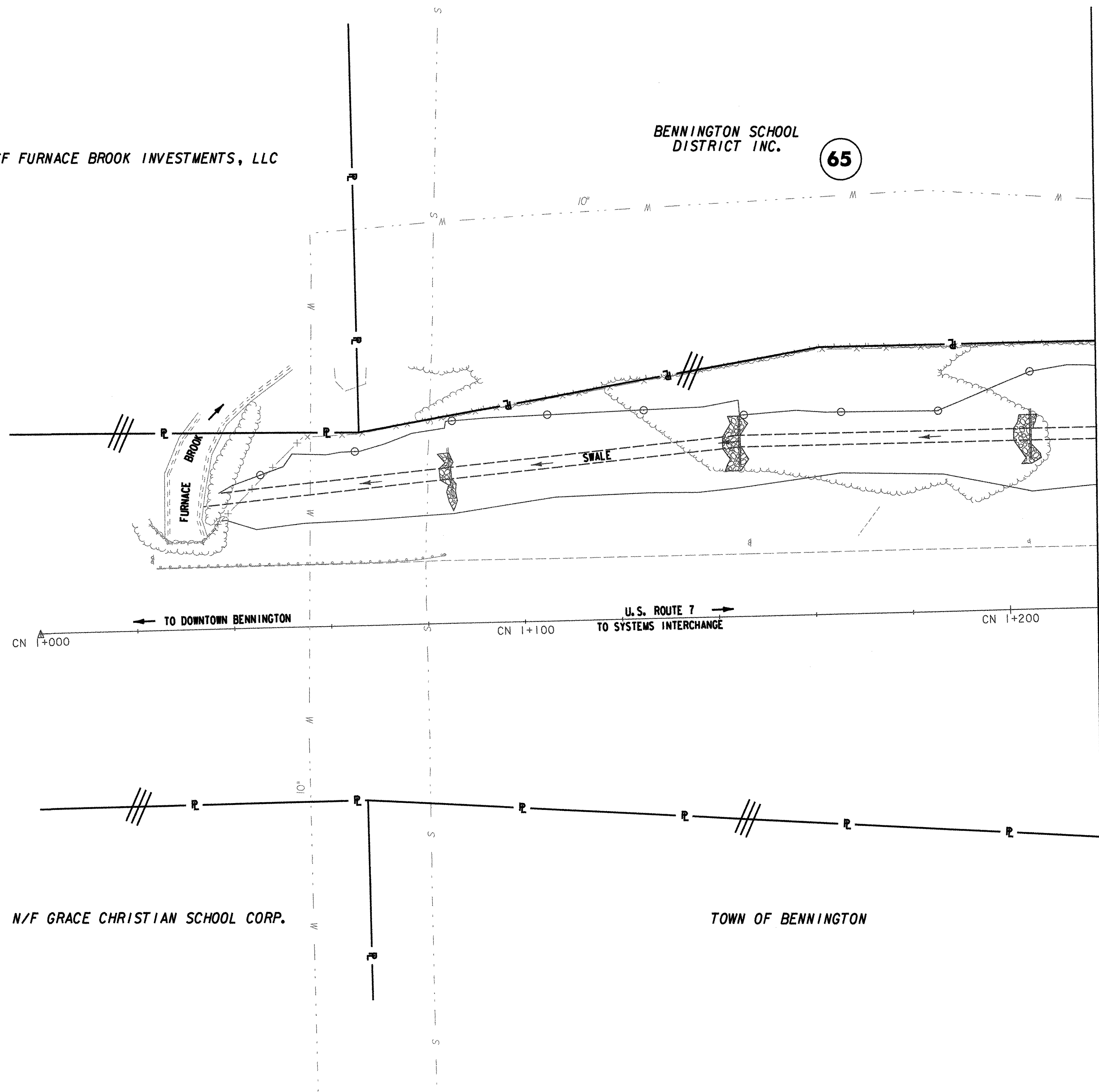

N/F GRACE CHRISTIAN SCHOOL CORP.

TOWN OF BENNINGTON

LINES SHOWN ON THIS PLAN AS EXISTING PROPERTY LINES P/L ARE BELIEVED TO BE ACCURATE BUT SHOULD NOT BE RELIED UPON FOR PURPOSES UNRELATED TO THE STATE OF VERMONT'S ACQUISITION OF LAND AND RIGHTS FOR THIS PROJECT.

THIS SHEET TO BE USED FOR RIGHT-OF-WAY INFORMATION ONLY

DATUM
 VERTICAL NAVD 88
 HORIZONTAL NAD 83 (1992)

0 10 20 30
 SCALE 1:500
 @ FULL SIZE

**R.O.W.
 PLAN
 ROW-22A**

| | |
|--|---------------------------------|
| PROJECT NAME: BENNINGTON BYPASS | PROJECT NUMBER: NH FO19-1(5) |
| DESIGN FILE NAME: c:\dh\bennington\row | PLOT DATE: 3-26-07 |
| PROJECT LEADER: JDP | DRAWN BY: MBB |
| | CHECKED BY: GAK |
| SHEET: 94A OF 112 | |

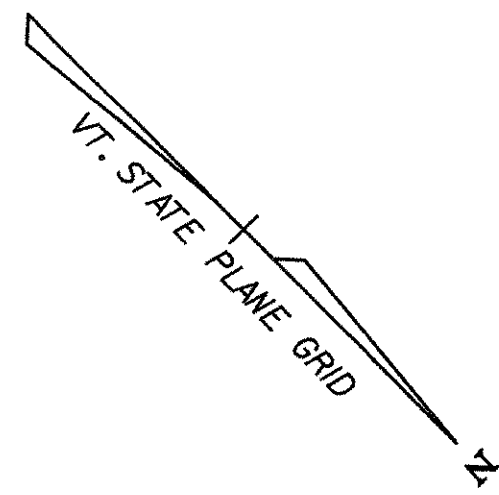

| CURVE F1 | |
|----------|-----------------------------------|
| Δ | = 242° 12' 47.6" RT. |
| R. | = 55.000m |
| T. | = N/A |
| L. | = 232.508m |
| E. | = N/A |
| BANK | = 0.060 |
| PI STA. | N/A |
| N | = N/A |
| E | = N/A |
| PC | N = 44953.7077 E = 442773.7869 |
| PT | N = 45027.5621 E = 442832.2329 |

| CURVE CNI | |
|-----------|-----------------------------------|
| Δ | = 91° 05' 41.6" |
| R. | = 465.700m |
| T. | = 474.685 |
| L. | = 740.419m |
| E. | = 199.283 |
| BANK | = 0.069 |
| Ls | = 61.000m |
| O | = 03° 45' 08.9" |
| Ts | = 572.307m |
| Lt | = 40.676m |
| St | = 20.342m |
| PI STA. | CN2+187.328 |
| N | = 45343.9089 |
| E | = 442869.5951 |
| TS | N = 44808.2875 E = 442868.6700 |
| SC | N = 44869.2261 E = 442871.1345 |
| CS | N = 45333.2994 E = 442395.0283 |
| ST | N = 45329.2762 E = 442334.1728 |

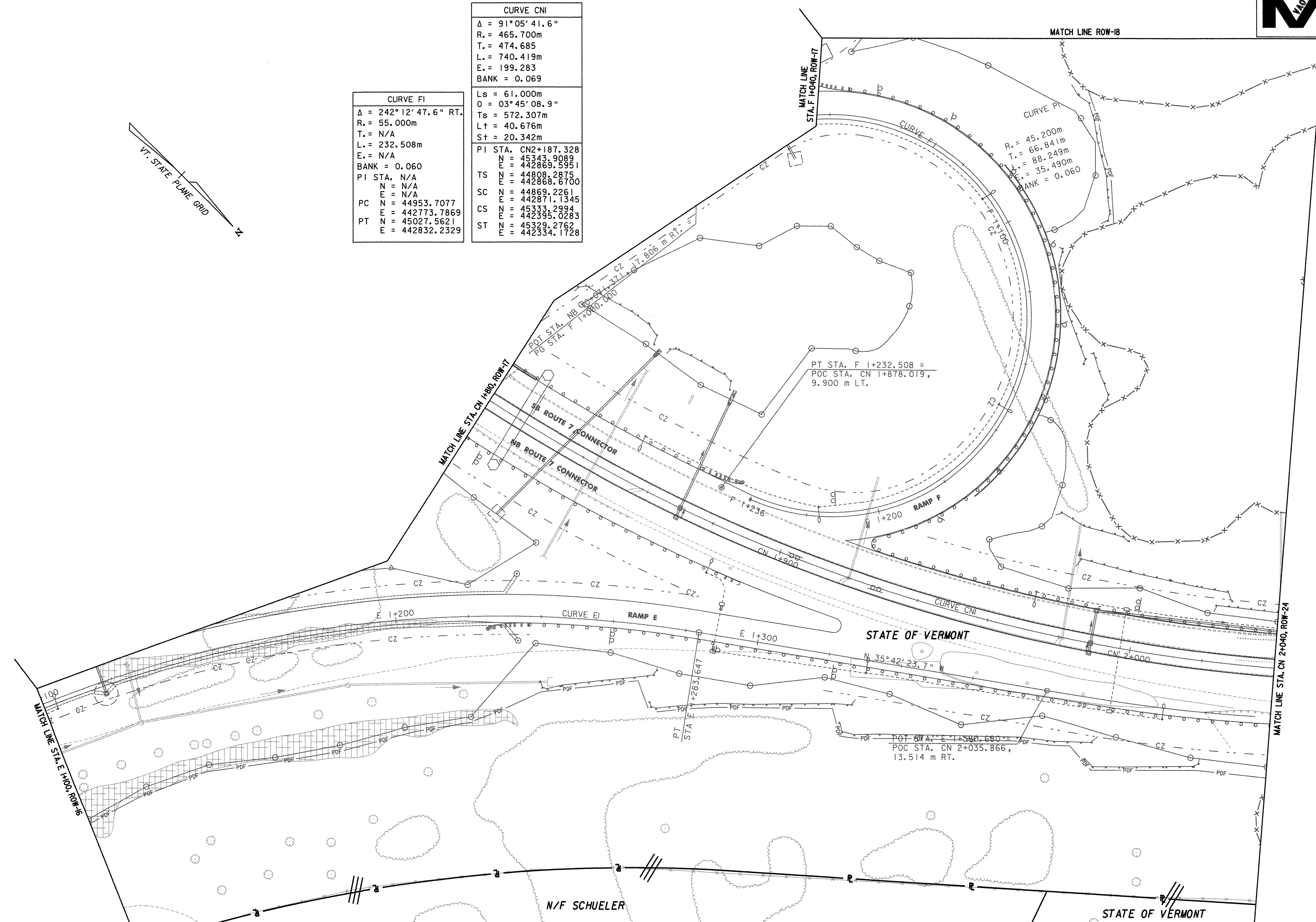

LINES SHOWN ON THIS PLAN AS EXISTING PROPERTY LINES P/L ARE BELIEVED TO BE ACCURATE BUT SHOULD NOT BE RELIED UPON FOR PURPOSES UNRELATED TO THE STATE OF VERMONT'S ACQUISITION OF LAND AND RIGHTS FOR THIS PROJECT.

THIS SHEET TO BE USED FOR RIGHT-OF-WAY INFORMATION ONLY

DATUM
VERTICAL NAVD 88
HORIZONTAL NAD 83 (1992)

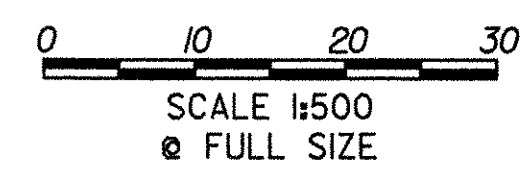

R.O.W. PLAN
ROW-23

| | |
|--|---------------------------------|
| PROJECT NAME: BENNINGTON BYPASS | PROJECT NUMBER: NH FO19-1(5) |
| DESIGN FILE NAME: c:\dh\bennington\row | PLOT DATE: 12-06-05 |
| PROJECT LEADER: JDP | DRAWN BY: MBB |
| | CHECKED BY: GAK |
| SHEET: 95 OF 112 | |



| CURVE S1 | CURVE CNI |
|------------------------------------|--------------------------------|
| $\Delta = 82^{\circ}08'14.5''$ RT. | $\Delta = 91^{\circ}05'41.6''$ |
| R. = 50.000m | R. = 465.700m |
| T. = 43.570m | T. = 474.685 |
| L. = 71.678m | L. = 740.419m |
| E. = 16.320m | E. = 199.283 |
| BANK = 0.060 | BANK = 0.069 |
| PI STA. S1+073.570 | Ls = 61.000m |
| N = 45209.2201 | $\theta = 03^{\circ}45'08.9''$ |
| E = 442713.9169 | Ts = 572.307m |
| PC N = 45184.4691 | Lt = 40.676m |
| E = 442678.0602 | St = 20.342m |
| PT N = 45177.0864 | |
| E = 442743.3403 | |

| CURVE Q1 |
|-------------------------------------|
| $\Delta = 116^{\circ}50'48.7''$ LT. |
| R. = 50.000m |
| T. = 81.348m |
| L. = 101.968m |
| E. = 45.486m |
| BANK = 0.060 |
| PI STA. Q1+081.348 |
| N = 45335.2497 |
| E = 442459.8160 |
| PC N = 45312.0287 |
| E = 442537.7797 |
| PT N = 45255.2024 |
| E = 442474.3069 |

| CURVE CN2 |
|------------------------------------|
| $\Delta = 91^{\circ}06'59.6''$ LT. |
| R. = 468.400m |
| T. = 477.618m |
| L. = 744.889m |
| E. = 200.568m |
| BANK = 0.069 |
| Ls = 61.177m |
| Os = $3^{\circ}44'29.9''$ |
| Ts = 575.534m |
| Lt = 40.793m |
| St = 20.400m |

| |
|----------------------|
| PI STA. CN 2+187.929 |
| N = 45346.7621 |
| E = 442872.3761 |
| TS N = 44808.0314 |
| E = 442871.3593 |
| SC N = 44848.7459 |
| E = 442873.8348 |
| CS N = 45335.9968 |
| E = 442394.8794 |
| ST N = 45335.5370 |
| E = 442374.4841 |

| CURVE R1 |
|------------------------------------|
| $\Delta = 84^{\circ}46'06.2''$ RT. |
| R. = 70.000m |
| T. = 63.883m |
| L. = 103.564m |
| E. = 24.769m |
| BANK = 0.060 |
| PI STA. R1+528.649 |
| N = 45318.1042 |
| E = 442458.0418 |
| PC N = 45312.5036 |
| E = 442394.4044 |
| PT N = 45255.2425 |
| E = 442469.4216 |

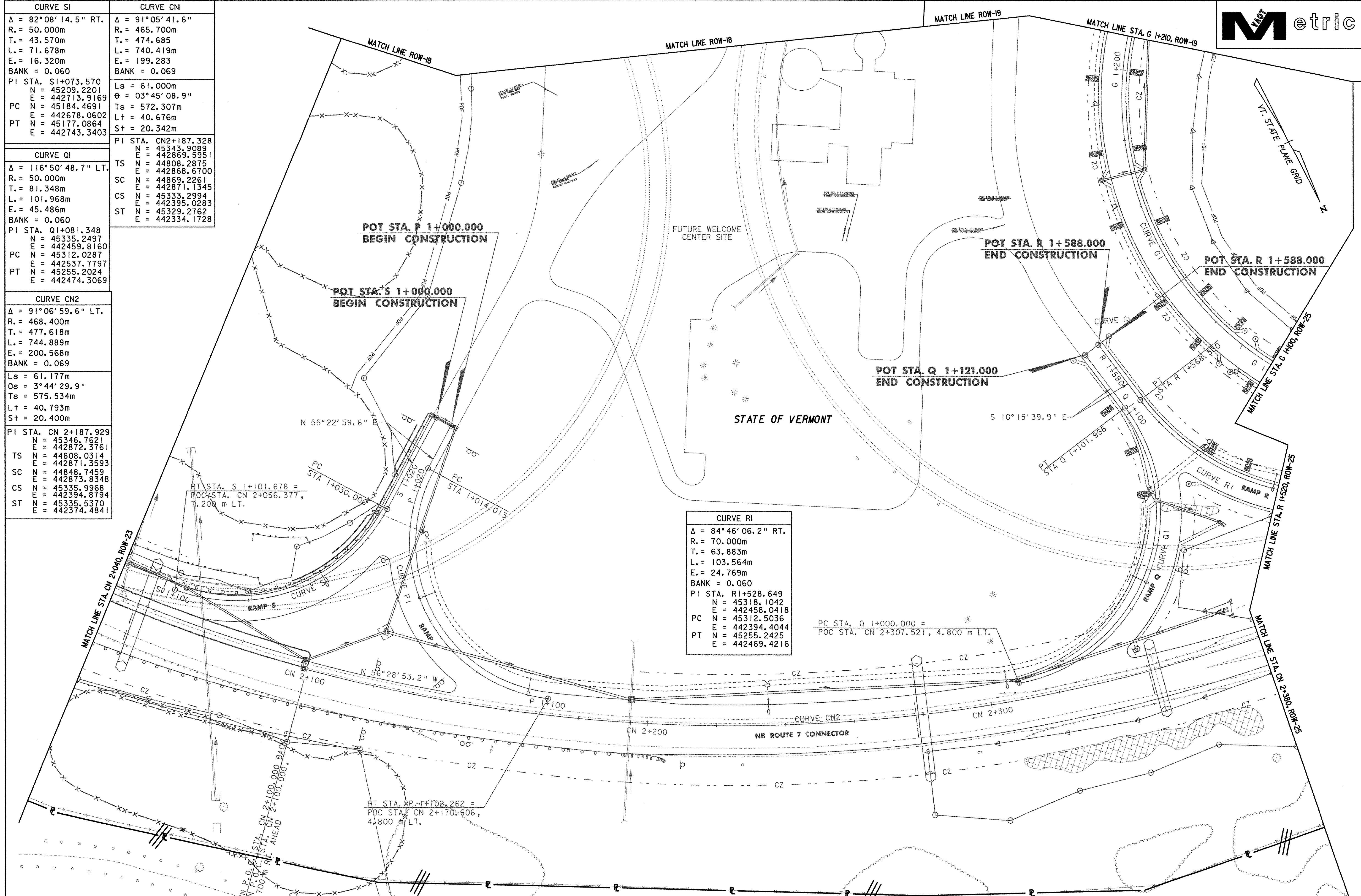

LINES SHOWN ON THIS PLAN AS EXISTING PROPERTY LINES P/L ARE BELIEVED TO BE ACCURATE BUT SHOULD NOT BE RELIED UPON FOR PURPOSES UNRELATED TO THE STATE OF VERMONT'S ACQUISITION OF LAND AND RIGHTS FOR THIS PROJECT.

THIS SHEET TO BE USED FOR RIGHT-OF-WAY INFORMATION ONLY

| DATUM | |
|------------|---------------|
| VERTICAL | NAVD 88 |
| HORIZONTAL | NAD 83 (1992) |

STATE OF VERMONT

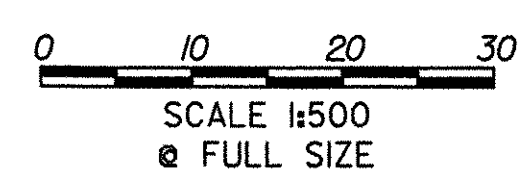

R.O.W. PLAN
ROW-24

| | |
|-------------------|----------------------|
| PROJECT NAME: | BENNINGTON BYPASS |
| DESIGN FILE NAME: | c:\dh\bennington\row |
| PROJECT LEADER: | JDP |

| | |
|-----------------|--------------|
| PROJECT NUMBER: | NH F019-1(5) |
|-----------------|--------------|

| | |
|-------------|----------|
| PLOT DATE: | 12-06-05 |
| DRAWN BY: | MBB |
| CHECKED BY: | GAK |

SHEET: 96 OF 112

| CURVE CN2 | |
|------------------------------------|--|
| $\Delta = 91^{\circ}06'59.6''$ LT. | |
| R. = 468.400m | |
| T. = 477.618m | |
| L. = 744.889m | |
| E. = 200.568m | |
| BANK = 0.069 | |
| LS = 61.177m | |
| OS = $3^{\circ}44'29.9''$ | |
| TS = 575.534m | |
| Lt = 40.793m | |
| St = 20.400m | |
| PI STA. CN 2+187.929 | |
| N = 45346.7621 | |
| E = 442872.3761 | |
| TS N = 44808.0314 | |
| E = 442871.3593 | |
| SC N = 44848.7459 | |
| E = 442873.8348 | |
| CS N = 45335.9968 | |
| E = 442394.8794 | |
| ST N = 45335.5370 | |
| E = 442374.4841 | |

| CURVE RI | |
|------------------------------------|--|
| $\Delta = 84^{\circ}46'06.2''$ RT. | |
| R. = 70.000m | |
| T. = 63.883m | |
| L. = 103.564m | |
| E. = 24.769m | |
| BANK = 0.060 | |
| PI STA. RI+528.649 | |
| N = 45318.1042 | |
| E = 442458.0418 | |
| PC N = 45312.5036 | |
| E = 442394.4044 | |
| PT N = 45255.2425 | |
| E = 442469.4216 | |

| | |
|-------------------------------------|--|
| $\Delta = 236^{\circ}03'34.7''$ RT. | |
| R. = 90.000m | |
| T. = N/A | |
| L. = 370.802m | |
| E. = N/A | |
| BANK = 0.060 | |
| PI STA. G1+396.514 | |
| N = 45179.3415 | |
| E = 442268.2761 | |
| PC N = 45305.8601 | |
| E = 442346.1949 | |
| PCC N = 45159.4245 | |
| E = 442284.5381 | |
| PT N = 45200.7744 | |
| E = 442254.0714 | |

| CURVE HI | |
|------------------------------------|--|
| $\Delta = 93^{\circ}31'06.3''$ RT. | |
| R. = 200.000m | |
| T. = 212.675m | |
| L. = 326.441m | |
| E. = 91.943m | |
| BANK = 0.060 | |
| PI STA. H 1+212.675 | |
| N = 45330.8404 | |
| E = 442166.8007 | |
| PC N = 45342.5925 | |
| E = 442379.1505 | |
| PT N = 45543.5112 | |
| E = 442168.1025 | |

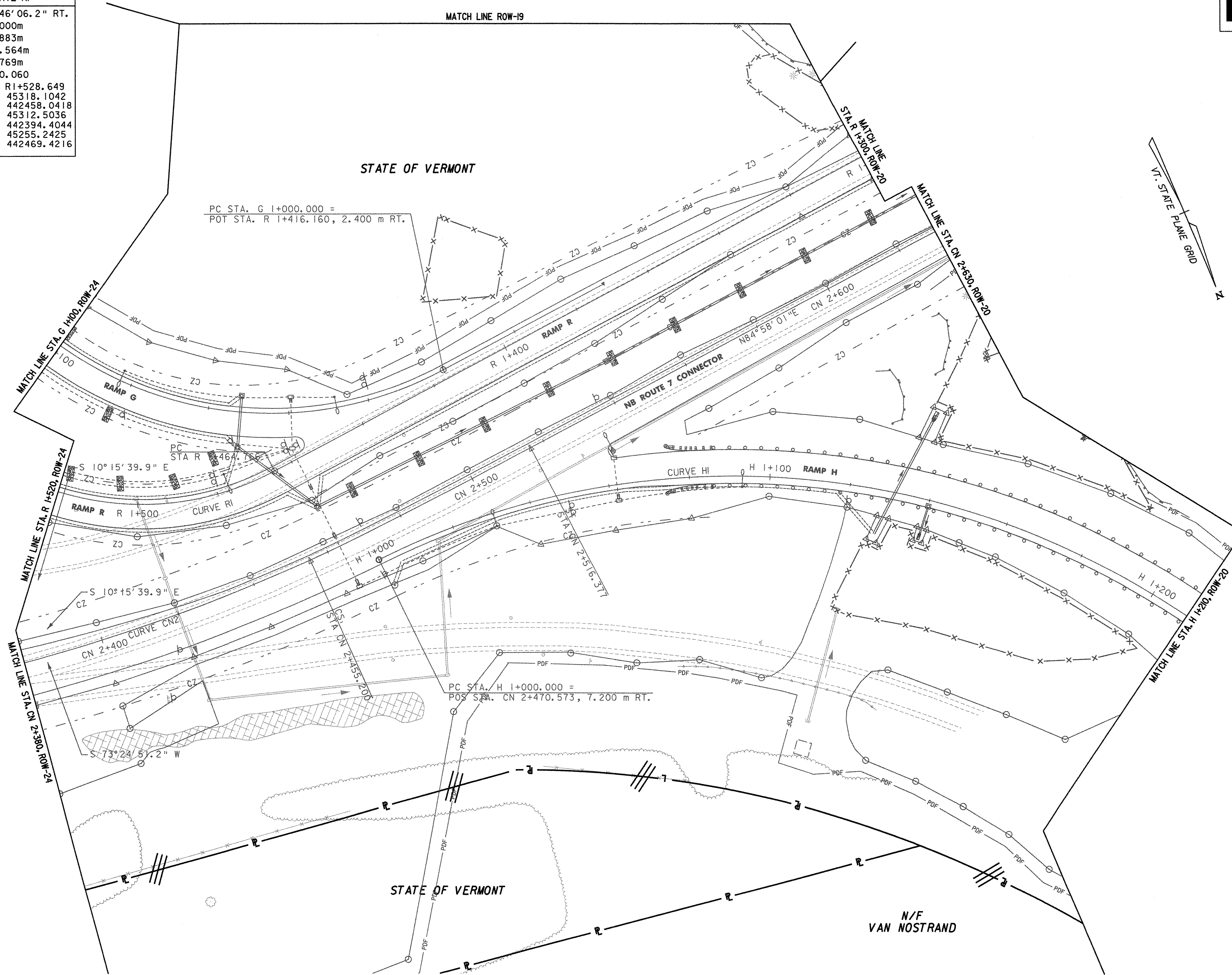

| DATUM | |
|------------|---------------|
| VERTICAL | NAVD 88 |
| HORIZONTAL | NAD 83 (1992) |

LINES SHOWN ON THIS PLAN AS EXISTING PROPERTY LINES P/L ARE BELIEVED TO BE ACCURATE BUT SHOULD NOT BE RELIED UPON FOR PURPOSES UNRELATED TO THE STATE OF VERMONT'S ACQUISITION OF LAND AND RIGHTS FOR THIS PROJECT.

THIS SHEET TO BE USED FOR RIGHT-OF-WAY INFORMATION ONLY

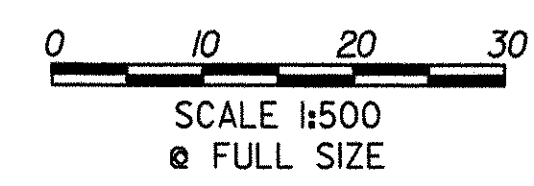

R.O.W. PLAN
ROW-25

PROJECT NAME: BENNINGTON BYPASS
DESIGN FILE NAME: c:\dh\bennington\row
PROJECT LEADER: JDP

PROJECT NUMBER: NH FO19-1(5)

PLOT DATE: 12-06-05
DRAWN BY: MBB
CHECKED BY: GAK

SHEET: 97 OF 112

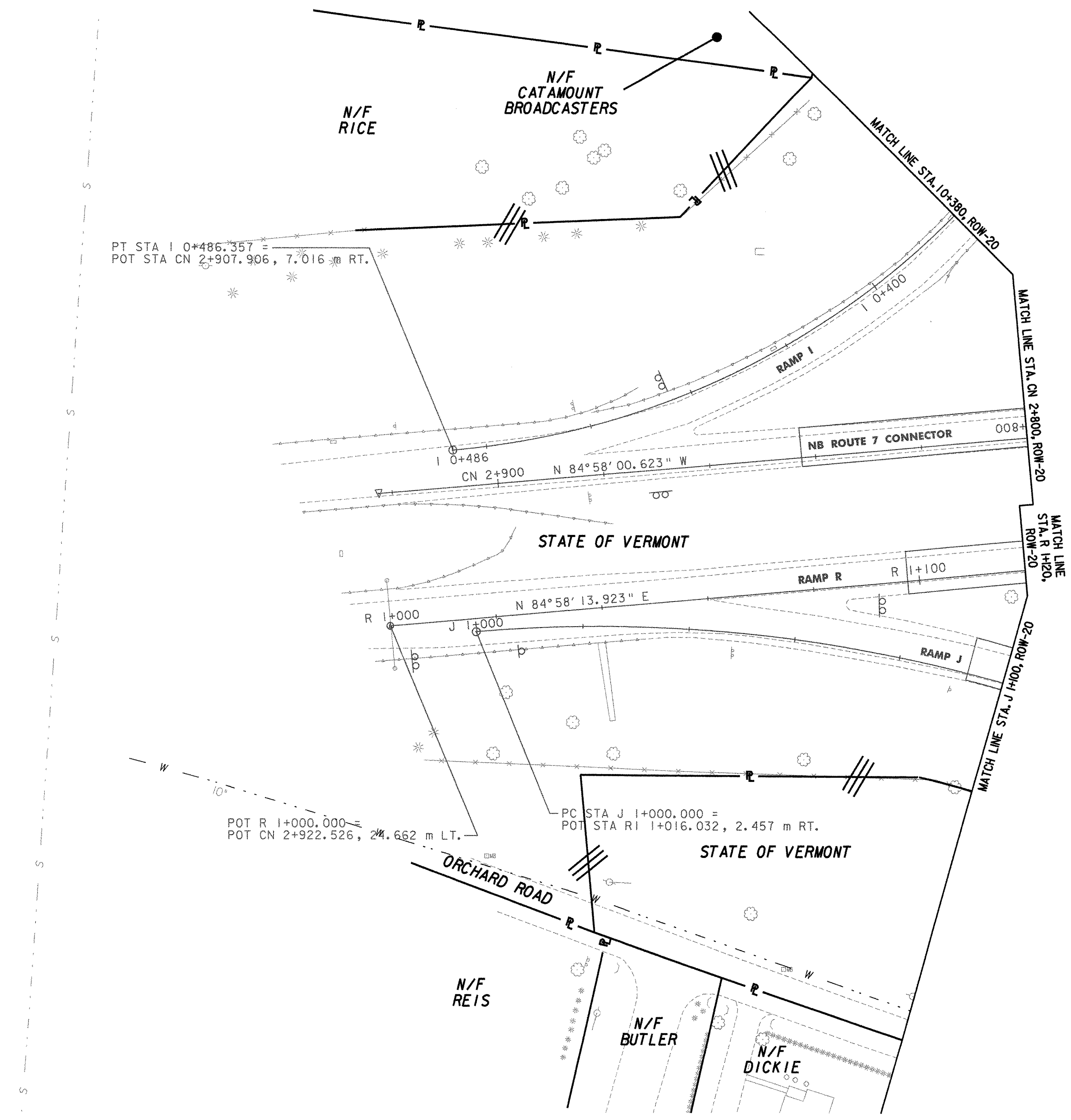
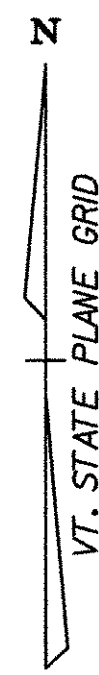

DATUM
 VERTICAL NAVD 88
 HORIZONTAL NAD 83 (1992)

LINES SHOWN ON THIS PLAN AS EXISTING PROPERTY LINES P/L ARE BELIEVED TO BE ACCURATE BUT SHOULD NOT BE RELIED UPON FOR PURPOSES UNRELATED TO THE STATE OF VERMONT'S ACQUISITION OF LAND AND RIGHTS FOR THIS PROJECT.

THIS SHEET TO BE USED FOR RIGHT-OF-WAY INFORMATION ONLY

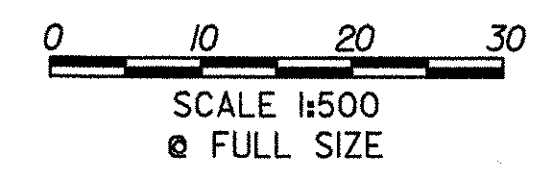

R.O.W. PLAN
ROW-26

| | |
|---|--|
| PROJECT NAME: BENNINGTON BYPASS | PROJECT NUMBER: NH F019-(15) |
| DESIGN FILE NAME: c:\dh\bennington\row | PLOT DATE: 12-06-05 |
| PROJECT LEADER: JDP | DRAWN BY: MBB |
| | CHECKED BY: GAK |
| SHEET: 98 OF 112 | |

MATCH LINE ROW-6A

MATCH LINE ROW-6

| CURVE VTI | | CURVE AI | |
|---------------------|---------------------|---------------------|---------------------|
| Δ = 17°09'41.0" RT. | Δ = 80°56'33.0" LT. | Δ = 80°56'33.0" LT. | Δ = 80°56'33.0" LT. |
| R = 650.000m | R = 50.000m | R = 50.000m | R = 50.000m |
| T = 98.079m | T = 42.661m | T = 42.661m | T = 42.661m |
| L = 194.690m | L = 70.636m | L = 70.636m | L = 70.636m |
| E = 7.358m | E = 15.726m | E = 15.726m | E = 15.726m |
| BANK = 0.000 | BANK = 0.000 | BANK = 0.000 | BANK = 0.000 |
| PI STA. VT1+328.646 | PI STA. VT1+067.071 | PI STA. VT1+067.071 | PI STA. VT1+067.071 |
| N = 42584.7678 | N = 42616.4811 | N = 42616.4811 | N = 42616.4811 |
| E = 445107.0398 | E = 445185.2094 | E = 445185.2094 | E = 445185.2094 |
| PC N = 42531.2076 | PC N = 42599.3298 | PC N = 42599.3298 | PC N = 42599.3298 |
| E = 445024.8764 | E = 445146.1483 | E = 445146.1483 | E = 445146.1483 |
| PT N = 42611.6999 | PT N = 42657.7551 | PT N = 42657.7551 | PT N = 42657.7551 |
| E = 445201.3488 | E = 445174.4213 | E = 445174.4213 | E = 445174.4213 |

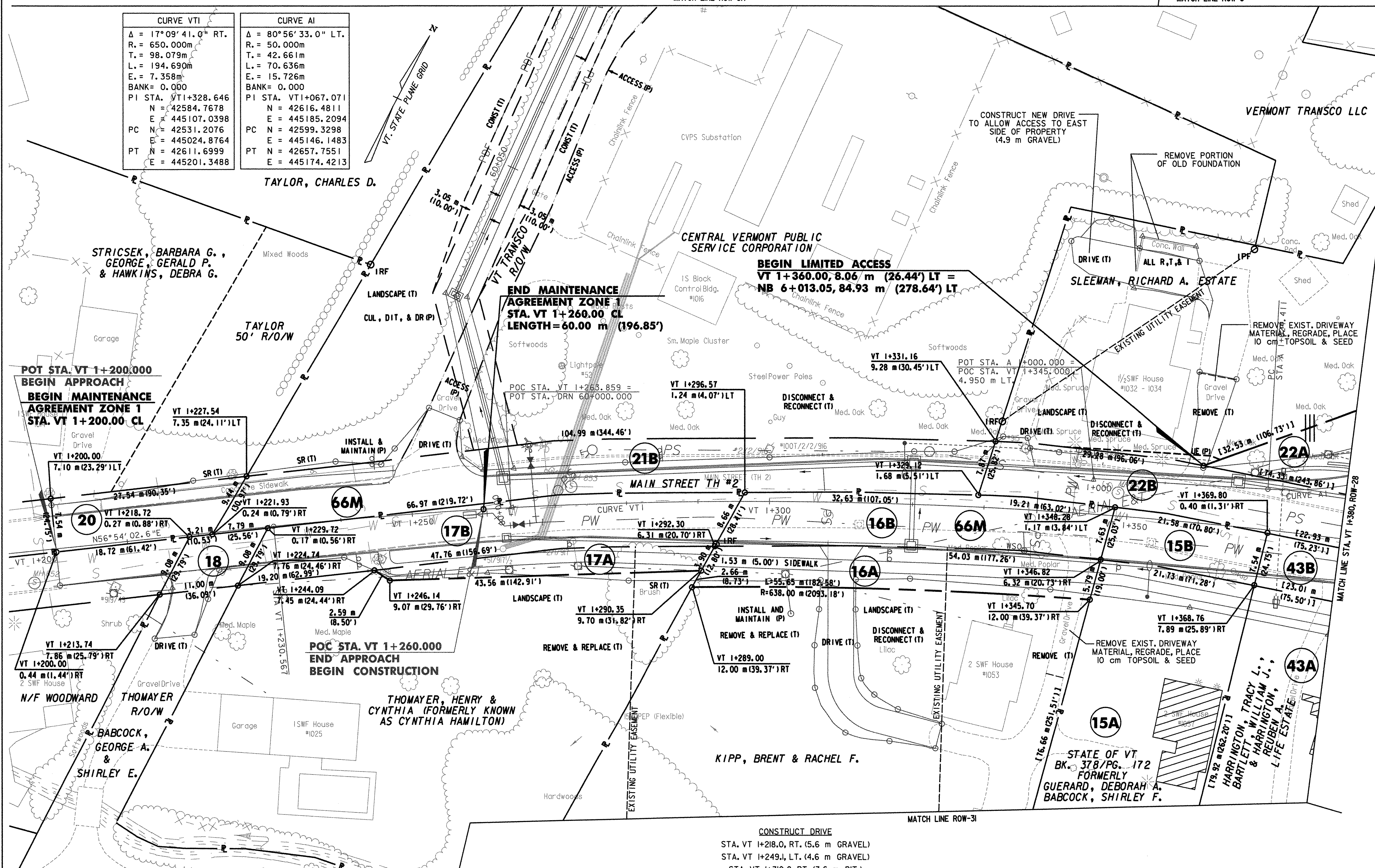

END MAINTENANCE AGREEMENT ZONE 1
STA. VT 1+260.00 CL
LENGTH = 60.00 m (196.85')

BEGIN LIMITED ACCESS
VT 1+360.00, 8.06 m (26.44') LT =
NB 6+013.05, 84.93 m (278.64') LT

POT STA. VT 1+200.000
BEGIN APPROACH
BEGIN MAINTENANCE AGREEMENT ZONE 1
STA. VT 1+200.00 CL

POC STA. VT 1+260.000
END APPROACH
BEGIN CONSTRUCTION

CONSTRUCT DRIVE
 STA. VT 1+218.0, RT. (5.6 m GRAVEL)
 STA. VT 1+249.1, LT. (4.6 m GRAVEL)
 STA. VT 1+310.0, RT. (3.6 m BIT.)
 STA. VT 1+331.4, LT. (3.4 m GRAVEL)

LINES SHOWN ON THIS PLAN AS EXISTING PROPERTY LINES P/L ARE BELIEVED TO BE ACCURATE BUT SHOULD NOT BE RELIED UPON FOR PURPOSES UNRELATED TO THE STATE OF VERMONT'S ACQUISITION OF LAND AND RIGHTS FOR THIS PROJECT.

THIS SHEET TO BE USED FOR RIGHT-OF-WAY INFORMATION ONLY

 SIGNIFIES DEMOLITION & REMOVAL OF STRUCTURES AND IMPROVEMENTS

SCALE 1:250 @ FULL SIZE

DATUM
 VERTICAL NAVD 88
 HORIZONTAL NAD 83 (1992)

| | | |
|-------------------------------------|--|----------------------------------|
| R.O.W. PLAN ROW-27 | PROJECT NAME: BENNINGTON BYPASS | PROJECT NUMBER: NH F019-(5) |
| | DESIGN FILE NAME: c:\dh\bennington\row | PLOT DATE: 3-26-07 |
| | PROJECT LEADER: JDP | DRAWN BY: MBB CHECKED BY: GAK |
| | | SHEET: 99 OF 112 |

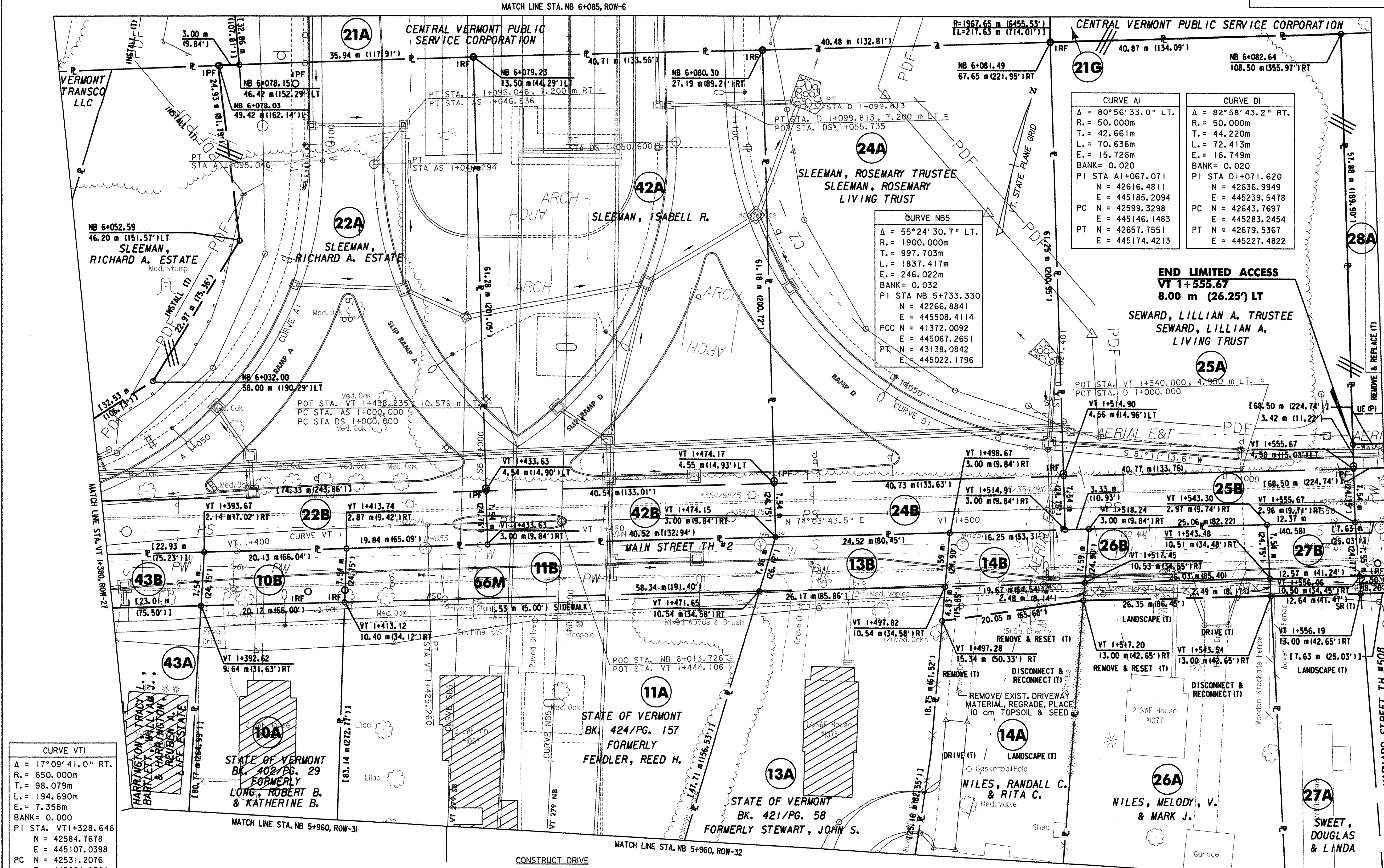

| CURVE AI | CURVE DI |
|---------------------|---------------------|
| Δ = 80°56'33.0" LT. | Δ = 82°58'43.2" RT. |
| R = 50.000m | R = 50.000m |
| T = 42.661m | T = 44.220m |
| L = 70.636m | L = 72.413m |
| E = 15.726m | E = 16.749m |
| BANK = 0.020 | BANK = 0.020 |
| PI STA AI+067.071 | PI STA DI+071.620 |
| N = 42616.4811 | N = 42636.9949 |
| E = 445185.2094 | E = 445239.5478 |
| PC N = 42599.3298 | PC N = 42643.7697 |
| E = 445146.1483 | E = 445283.2454 |
| PT N = 42657.7551 | PT N = 42679.5367 |
| E = 445174.4213 | E = 445227.4822 |

| CURVE NB5 |
|---------------------|
| Δ = 55°24'30.7" LT. |
| R = 1900.000m |
| T = 997.703m |
| L = 1837.417m |
| E = 246.022m |
| BANK = 0.032 |
| PI STA NB 5+733.330 |
| N = 42266.8841 |
| E = 445508.4114 |
| PCC N = 41372.0092 |
| E = 445067.2651 |
| PT N = 43138.0842 |
| E = 445022.1796 |

| CURVE VTI |
|---------------------|
| Δ = 17°09'41.0" RT. |
| R = 650.000m |
| T = 98.079m |
| L = 194.690m |
| E = 7.358m |
| BANK = 0.000 |
| PI STA. VTI+328.646 |
| N = 42584.7678 |
| E = 445107.0398 |
| PC N = 42531.2076 |
| E = 445024.8764 |
| PT N = 42611.6999 |
| E = 445201.3488 |

LINES SHOWN ON THIS PLAN AS EXISTING PROPERTY LINES P/L ARE BELIEVED TO BE ACCURATE BUT SHOULD NOT BE RELIED UPON FOR PURPOSES UNRELATED TO THE STATE OF VERMONT'S ACQUISITION OF LAND AND RIGHTS FOR THIS PROJECT.

THIS SHEET TO BE USED FOR RIGHT-OF-WAY INFORMATION ONLY

CONSTRUCT DRIVE STA. VT 1+502.5, RT. (3.6 m BIT.) STA. VT 1+537.0, RT. (3.5 m GRAVEL)

PORTLAND CEMENT CONCRETE SIDEWALK, 125 mm STA. VT 1+530.4, RT. (INDIVIDUAL WALKWAY, 1.5 m)

SIGNIFIES DEMOLITION & REMOVAL OF STRUCTURES AND IMPROVEMENTS

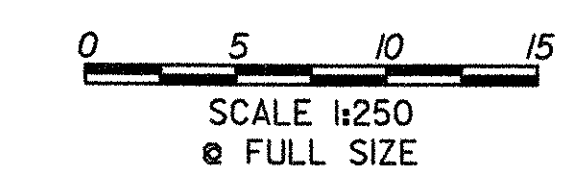

R.O.W. PLAN
ROW-28

| | |
|---|--|
| PROJECT NAME: BENNINGTON BYPASS | PROJECT NUMBER: NH FO19-1(5) |
| DESIGN FILE NAME: c:\nh\bennington\row | PLOT DATE: 4-25-07 |
| PROJECT LEADER: JDP | DRAWN BY: MBB |
| | CHECKED BY: GAK |
| SHEET: 100 OF 112 | |

CURVE VT2

Δ = 2°09'50.7" LT.
 R = 1200.000m
 T = 22.665m
 L = 45.324m
 E = 0.214m
 BANK = 0.020
 PI STA. VT 1+713.794
 N = 42690.9310
 E = 445478.7950
 PC N = 42684.7073
 E = 445457.0014
 PT N = 42697.9732
 E = 445500.3380

CONSTRUCT DRIVE

STA. VT 1+573.6, LT. (12.0 m GRAVEL)
 STA. VT 1+582.2, RT. (2.5 m BIT.)
 STA. VT 1+593.7, RT. (2.4 m BIT.)
 STA. VT 1+612.6, LT. (6.5 m GRAVEL)
 STA. VT 1+655.2, LT. (6.4 m GRAVEL)
 STA. VT 1+677.0, RT. (3.4 m GRAVEL)
 STA. VT 1+678.9, LT. (26.0 m GRAVEL)

CONSTRUCT APPROACH

STA. VT 1+563.5, RT. (6.0 m BIT. HARVARD ST)
 STA. VT 1+651.5, RT. (6.0 m BIT. HICKORY HILL)

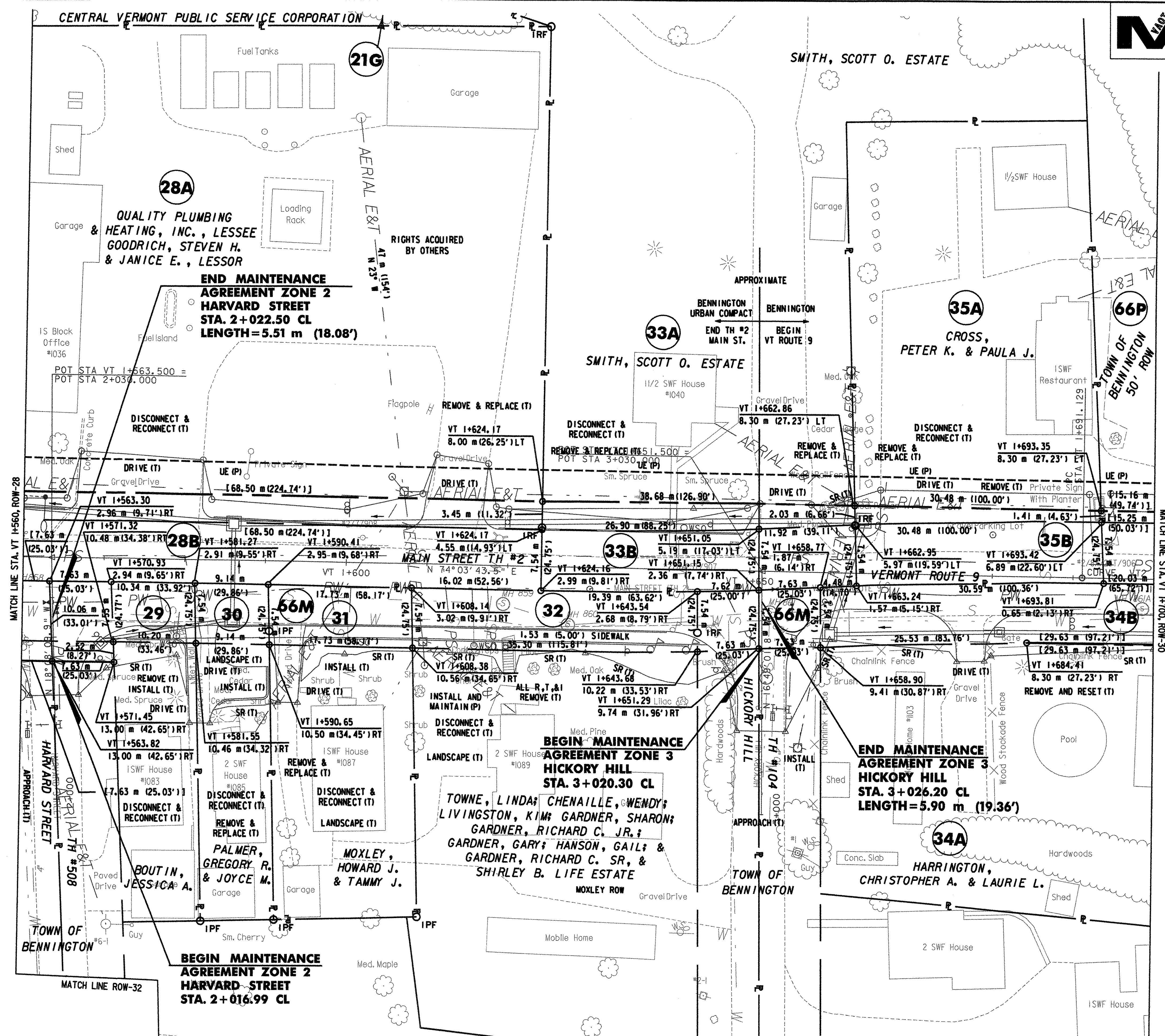

DATUM

VERTICAL NAVD 88
 HORIZONTAL NAD 83 (1992)

LINES SHOWN ON THIS PLAN AS EXISTING PROPERTY LINES P/L ARE BELIEVED TO BE ACCURATE BUT SHOULD NOT BE RELIED UPON FOR PURPOSES UNRELATED TO THE STATE OF VERMONT'S ACQUISITION OF LAND AND RIGHTS FOR THIS PROJECT.

THIS SHEET TO BE USED FOR RIGHT-OF-WAY INFORMATION ONLY

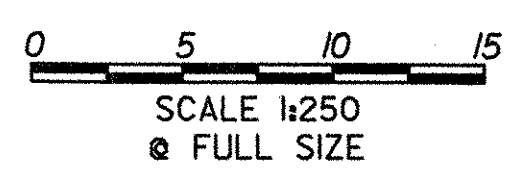

| | | |
|-------------------------------|--|----------------------------------|
| R.O.W. PLAN ROW-29 | PROJECT NAME: BENNINGTON BYPASS | PROJECT NUMBER: NH F019-(K5) |
| | DESIGN FILE NAME: c:\dh\bennington\row | PLOT DATE: 4-25-07 |
| | PROJECT LEADER: JDP | DRAWN BY: MBB CHECKED BY: GAK |
| SHEET: 101 OF 112 | | |

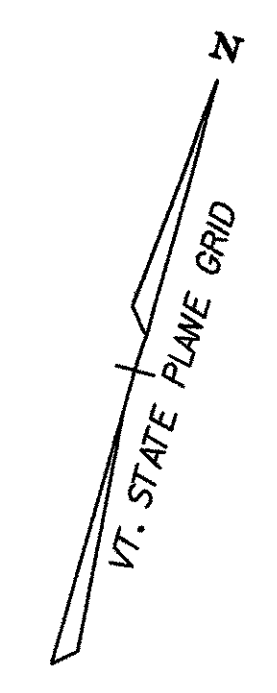

| CURVE VT2 | |
|------------|------------------|
| Δ = | 2° 09' 50.7" LT. |
| R = | 1200.000m |
| T = | 22.665m |
| L = | 45.324m |
| E = | 0.214m |
| BANK = | 0.020 |
| PI STA. VT | 1+713.794 |
| N = | 42690.9310 |
| E = | 445478.7950 |
| PC N = | 42684.7073 |
| E = | 445457.0014 |
| PT N = | 42697.9732 |
| E = | 445500.3380 |

42C
SLEEMAN, ISABELL R.

POT STA. VT 1+820.00
END APPROACH

POT STA. VT 1+760.000
END CONSTRUCTION
BEGIN APPROACH

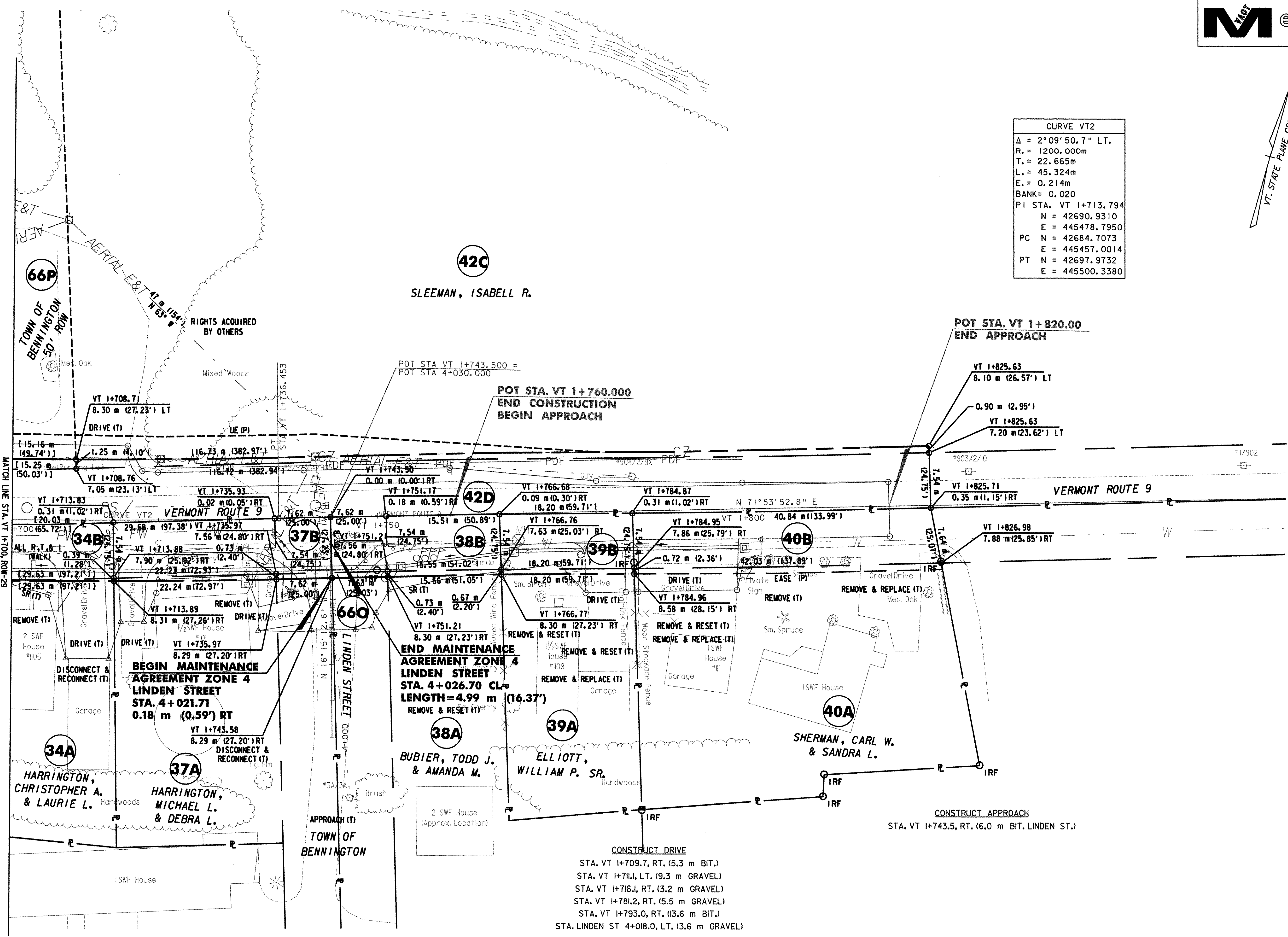

LINES SHOWN ON THIS PLAN AS EXISTING PROPERTY LINES P/L ARE BELIEVED TO BE ACCURATE BUT SHOULD NOT BE RELIED UPON FOR PURPOSES UNRELATED TO THE STATE OF VERMONT'S ACQUISITION OF LAND AND RIGHTS FOR THIS PROJECT.

THIS SHEET TO BE USED FOR RIGHT-OF-WAY INFORMATION ONLY

| | |
|------------|---------------|
| DATUM | |
| VERTICAL | NAVD 88 |
| HORIZONTAL | NAD 83 (1992) |

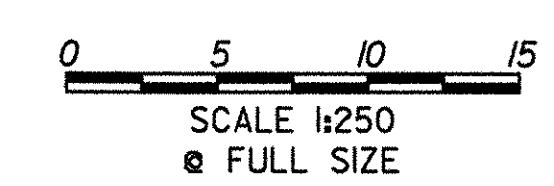

| | | |
|-------------------------------------|--|----------------------------------|
| R.O.W. PLAN ROW-30 | PROJECT NAME: BENNINGTON BYPASS | PROJECT NUMBER: NH F019-1(5) |
| | DESIGN FILE NAME: c:\dh\bennington\row | PLOT DATE: 3-26-07 |
| | PROJECT LEADER: JDP | DRAWN BY: MBB CHECKED BY: GAK |
| | | SHEET: 102 OF 112 |

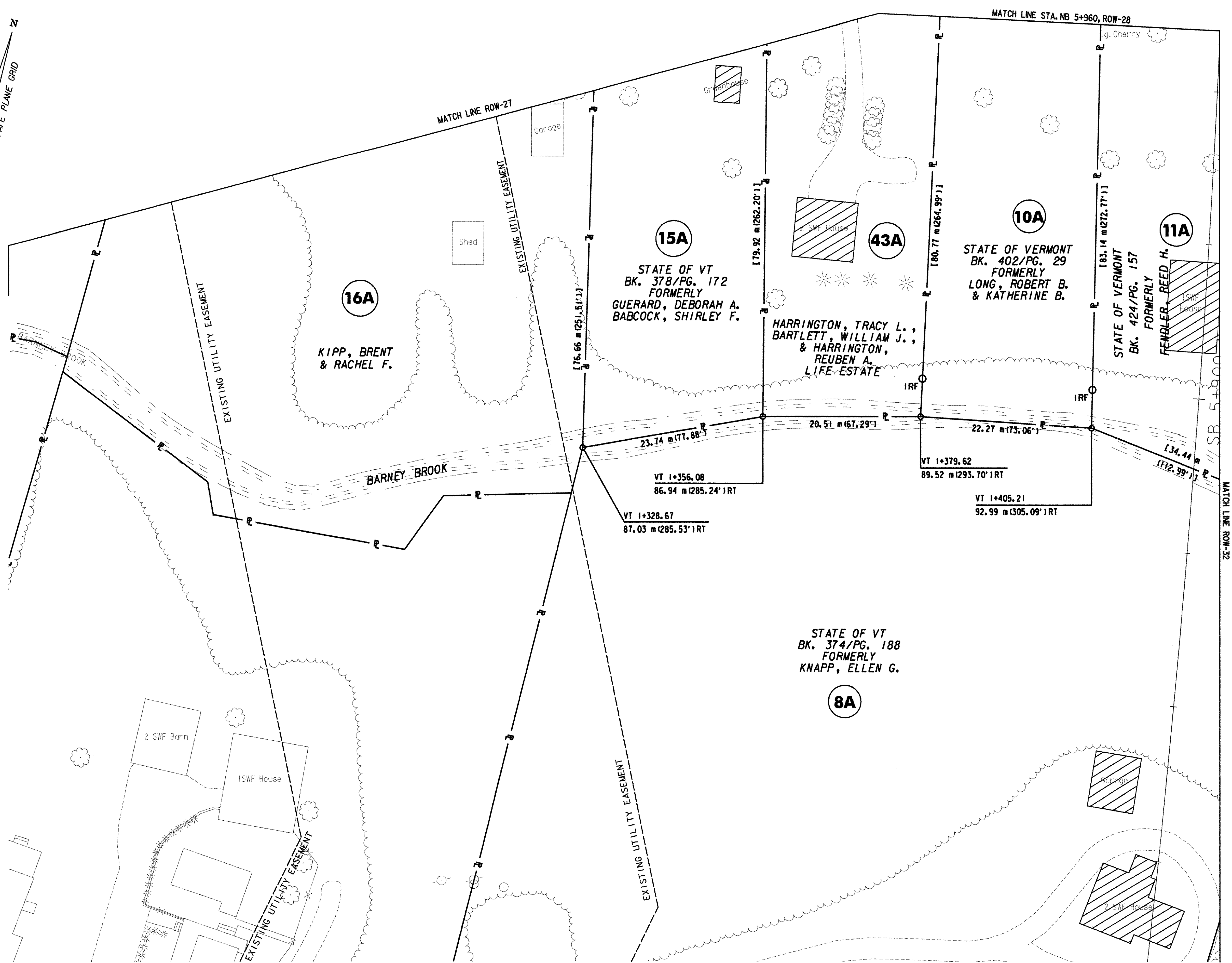
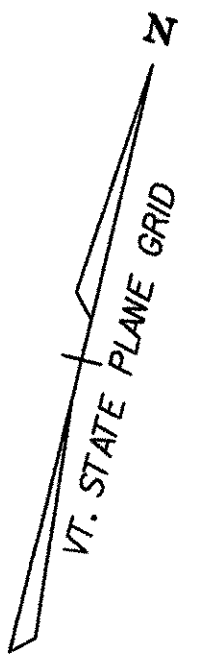

| | |
|--------------|---------------|
| DATUM | |
| VERTICAL | NAVD 88 |
| HORIZONTAL | NAD 83 (1992) |

LINES SHOWN ON THIS PLAN AS EXISTING PROPERTY LINES P/L ARE BELIEVED TO BE ACCURATE BUT SHOULD NOT BE RELIED UPON FOR PURPOSES UNRELATED TO THE STATE OF VERMONT'S ACQUISITION OF LAND AND RIGHTS FOR THIS PROJECT.

THIS SHEET TO BE USED FOR RIGHT-OF-WAY INFORMATION ONLY

SIGNIFIES DEMOLITION & REMOVAL OF STRUCTURES AND IMPROVEMENTS

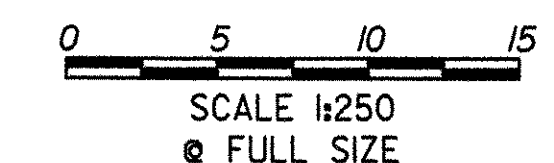

| | | |
|-----------------------------------|--|---------------------------------|
| R.O.W. PLAN ROW-31 | PROJECT NAME: BENNINGTON BYPASS | PROJECT NUMBER: NH FO19-1(5) |
| | DESIGN FILE NAME: c:\nh\bennington\row | PLOT DATE: 4-09-07 |
| | PROJECT LEADER: JDP | DRAWN BY: MBB |
| | | CHECKED BY: GAK |
| | | SHEET: 103 OF 112 |

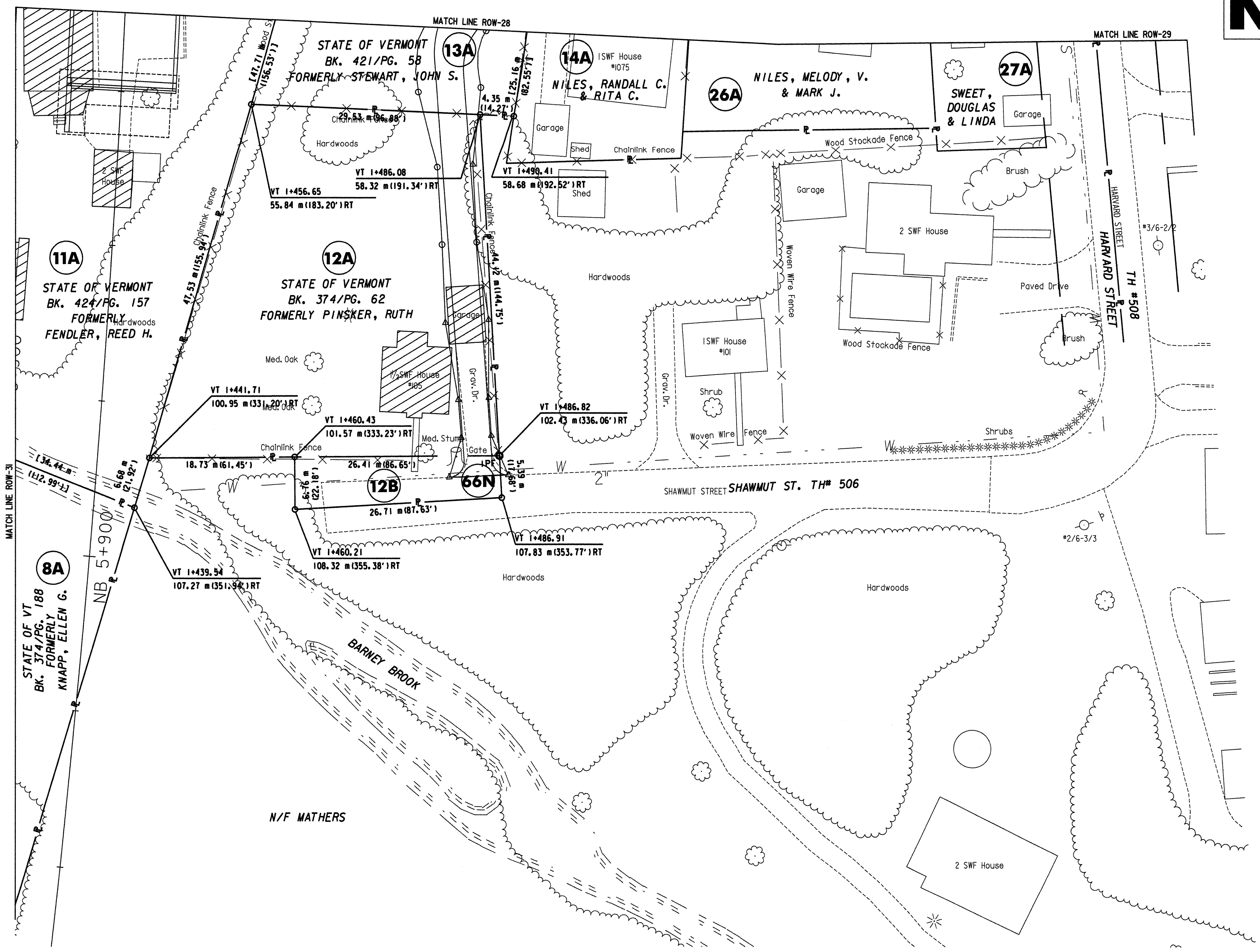
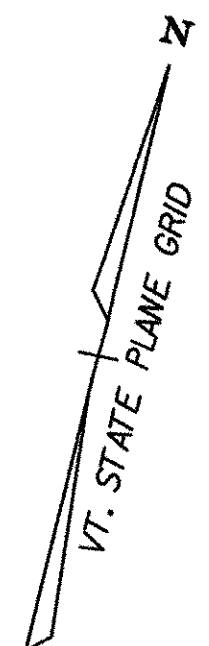

LINES SHOWN ON THIS PLAN AS EXISTING PROPERTY LINES P/L ARE BELIEVED TO BE ACCURATE BUT SHOULD NOT BE RELIED UPON FOR PURPOSES UNRELATED TO THE STATE OF VERMONT'S ACQUISITION OF LAND AND RIGHTS FOR THIS PROJECT.

THIS SHEET TO BE USED FOR RIGHT-OF-WAY INFORMATION ONLY

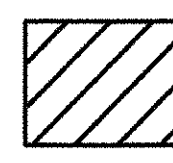
 SIGNIFIES DEMOLITION & REMOVAL OF STRUCTURES AND IMPROVEMENTS

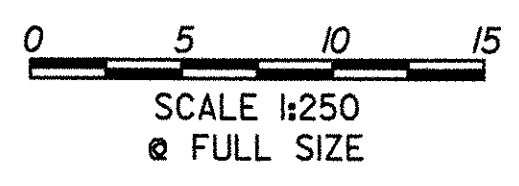

DATUM
 VERTICAL NAVD 88
 HORIZONTAL NAD 83 (1992)

R.O.W. PLAN
ROW-32

PROJECT NAME: **BENNINGTON BYPASS**
 DESIGN FILE NAME: c:\dh\bennington\row
 PROJECT LEADER: JDP

PROJECT NUMBER: **NH FO19-1(5)**
 PLOT DATE: 3-26-07
 DRAWN BY: MBB
 CHECKED BY: GAK
 SHEET: **104** OF **112**

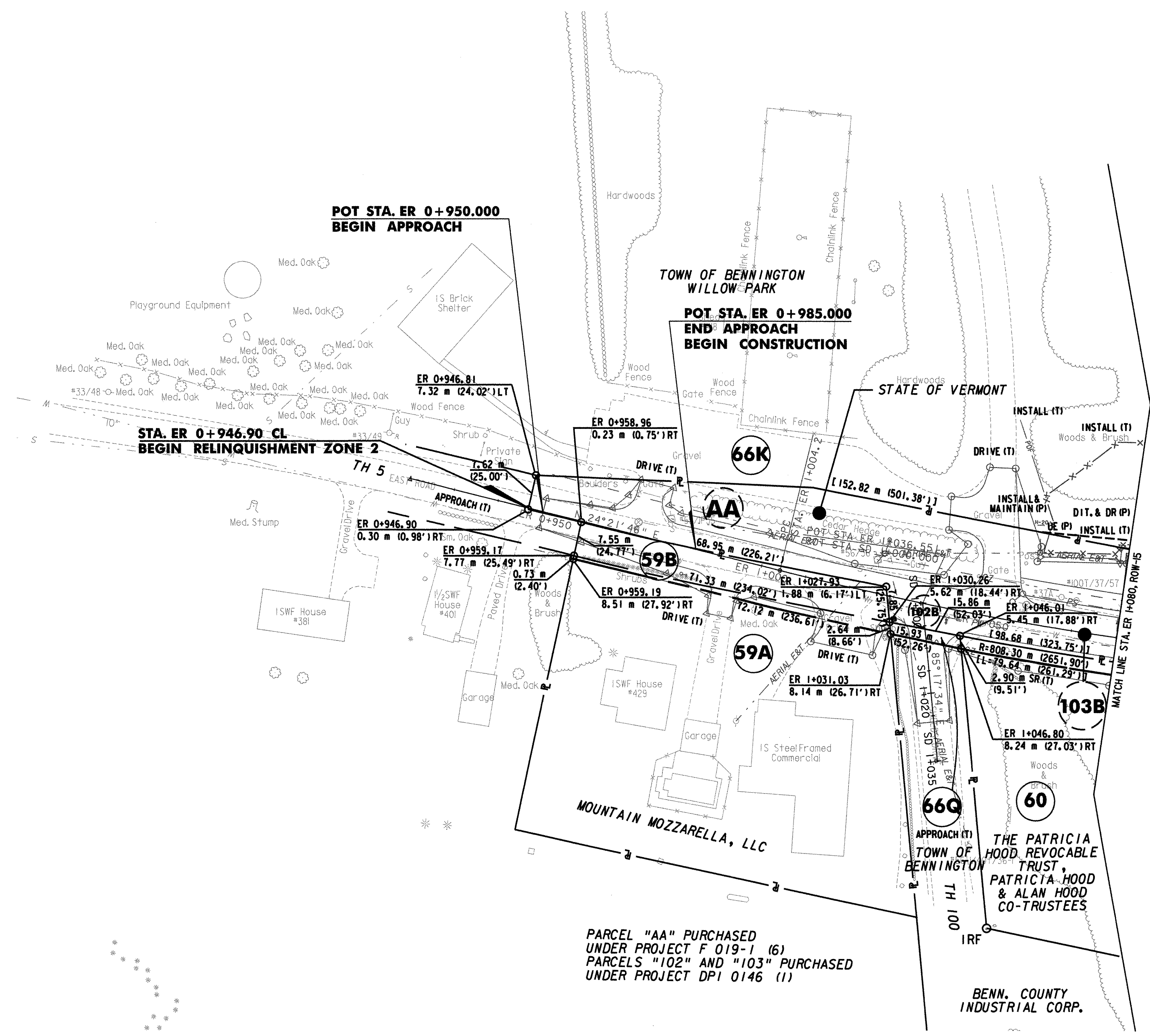
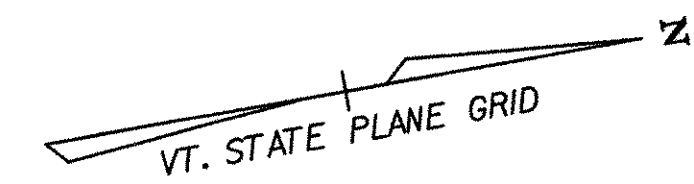

CONSTRUCT DRIVE
 STA. ER 0+972.0, LT. (7.4 m BIT.)
 STA. ER 0+993.0, RT. (5.4 m GRAVEL)
 STA. ER 1+020.0, RT. (15.0 m GRAVEL)
 STA. ER 1+054.0, LT. (8.2 m BIT.)

CONSTRUCT APPROACH
 STA. ER 1+036.6, RT. (7.2 m BIT. SHIELDS DRIVE)

PARCEL "AA" PURCHASED
 UNDER PROJECT F 019-1 (6)
 PARCELS "102" AND "103" PURCHASED
 UNDER PROJECT DPI 0146 (1)

| CURVE ERI | CURVE EDI |
|------------------------------------|------------------------------------|
| $\Delta = 16^\circ 42' 48.2''$ LT. | $\Delta = 26^\circ 41' 49.6''$ LT. |
| R. = 800.000m | R. = 100.000m |
| T. = 117.516m | T. = 23.729m |
| L. = 233.363m | L. = 46.595m |
| E. = 8.585m | E. = 2.777m |
| BANK = 0.000 | BANK = N/A |
| PI STA. ER 1+121.710 | PI STA. X01+066.450 |
| N = 44784.9998 | N = 44735.9035 |
| E = 443552.3856 | E = 443526.7363 |
| PC N = 44677.5126 | PC N = 44713.7279 |
| E = 443504.8830 | E = 443518.2933 |
| PT N = 44901.6072 | PT N = 44759.5083 |
| E = 443566.9699 | E = 443524.3164 |

LINES SHOWN ON THIS PLAN AS EXISTING PROPERTY LINES P/L ARE BELIEVED TO BE ACCURATE BUT SHOULD NOT BE RELIED UPON FOR PURPOSES UNRELATED TO THE STATE OF VERMONT'S ACQUISITION OF LAND AND RIGHTS FOR THIS PROJECT.

THIS SHEET TO BE USED FOR RIGHT-OF-WAY INFORMATION ONLY

DATUM
 VERTICAL NAVD 88
 HORIZONTAL NAD 83 (1992)

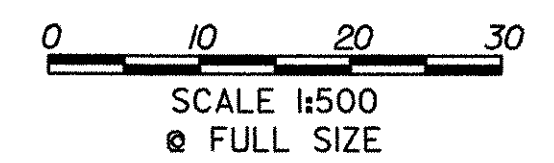

| | | |
|-----------------------------------|--|----------------------------------|
| R.O.W. PLAN ROW-33 | PROJECT NAME: BENNINGTON BYPASS | PROJECT NUMBER: NH F019-1(5) |
| | DESIGN FILE NAME: c:\dh\bennington\row | PLOT DATE: 1-30-06 |
| | PROJECT LEADER: JDP | DRAWN BY: MBB CHECKED BY: GAK |
| SHEET: 105 OF 112 | | |



MATCHLINE - SHEET ROW-DD

MATCHLINE - SHEET ROW-CC

④ JANE COLE REALTY LLC

BURT, C. OLIVER III

NORTH BRANCH REALTY TRUST
MICHAEL A. DEEP, TRUSTEE

MATCHLINE - SHEET ROW-AA

MATCHLINE - SHEET ROW-AA

VT. RTE. 9

LINES SHOWN ON THIS PLAN AS EXISTING PROPERTY LINES P/L ARE BELIEVED TO BE ACCURATE BUT SHOULD NOT BE RELIED UPON FOR PURPOSES UNRELATED TO THE STATE OF VERMONT'S ACQUISITION OF LAND AND RIGHTS FOR THIS PROJECT.

THIS SHEET TO BE USED FOR RIGHT-OF-WAY INFORMATION ONLY

DATUM
VERTICAL NAVD 88
HORIZONTAL NAD 83 (1992)

0 50 100 150
SCALE 1:2500
@ FULL SIZE

ROW PLAN
ROW-BB

PROJECT NAME:
BENNINGTON BYPASS
DESIGN FILE NAME: c:\dh\bennington\row
PROJECT LEADER: JDP

PROJECT NUMBER:
NH F019-1(5)

PLOT DATE: 12-05-05
DRAWN BY: ADM
CHECKED BY: GAK

SHEET: 107 OF 112

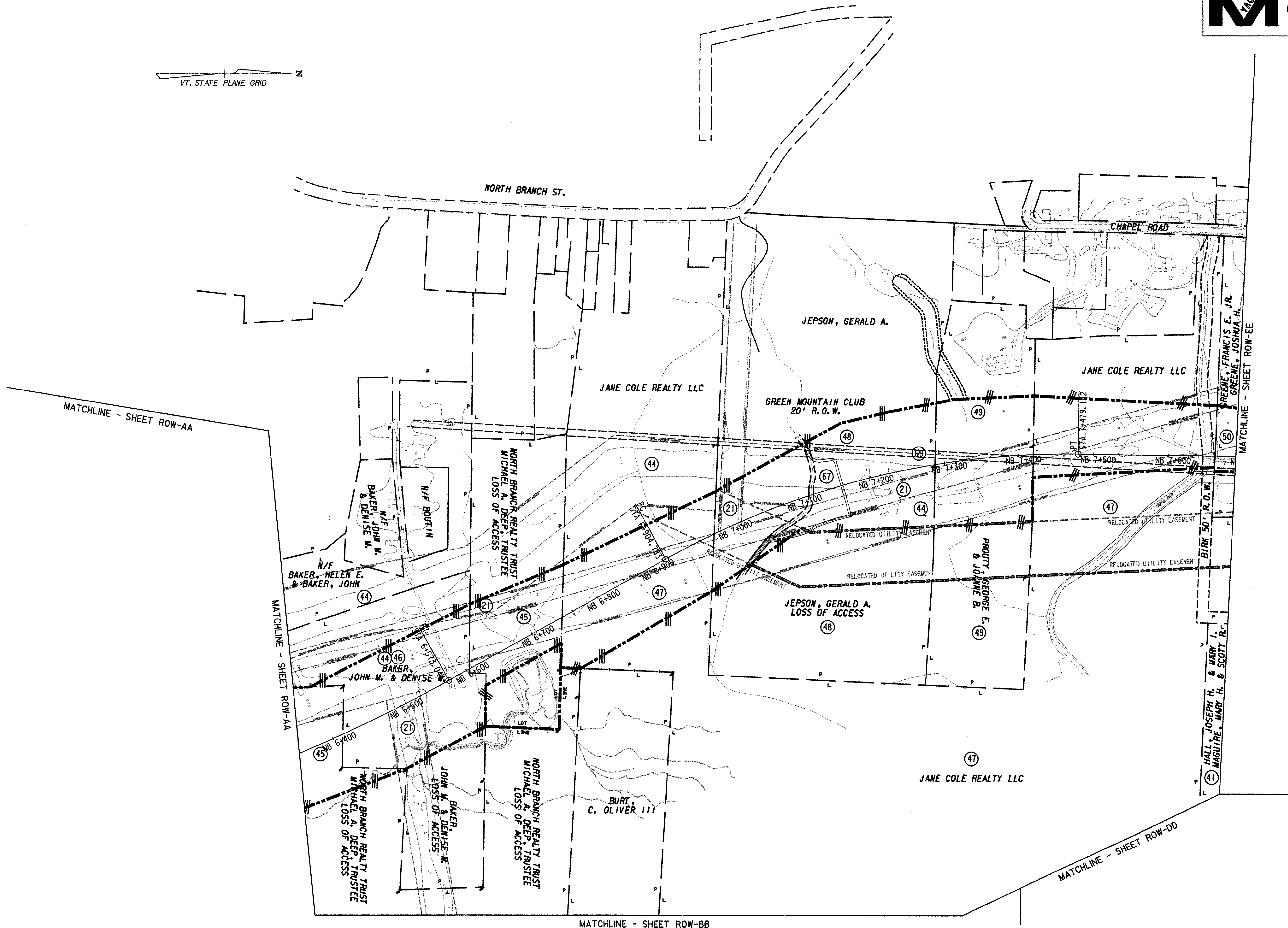

LINES SHOWN ON THIS PLAN AS EXISTING PROPERTY LINES P/L ARE BELIEVED TO BE ACCURATE BUT SHOULD NOT BE RELIED UPON FOR PURPOSES UNRELATED TO THE STATE OF VERMONT'S ACQUISITION OF LAND AND RIGHTS FOR THIS PROJECT.

THIS SHEET TO BE USED FOR RIGHT-OF-WAY INFORMATION ONLY

DATUM
 VERTICAL NAVD 88
 HORIZONTAL NAD 83 (1992)

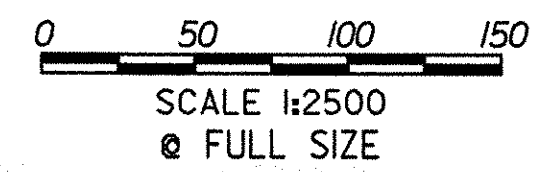

| | | |
|----------------------------------|--|---------------------------------|
| ROW PLAN ROW-CC | PROJECT NAME: BENNINGTON BYPASS | PROJECT NUMBER: NH F019-1(5) |
| | DESIGN FILE NAME: c:\dh\bennington\row | PLOT DATE: 12-05-05 |
| | PROJECT LEADER: JDP | DRAWN BY: ADM |
| | | CHECKED BY: GAK |
| | | SHEET: 108 OF 112 |



MATCHLINE - SHEET ROW-CC

MATCHLINE - SHEET ROW-EE

MATCHLINE - SHEET ROW-BB

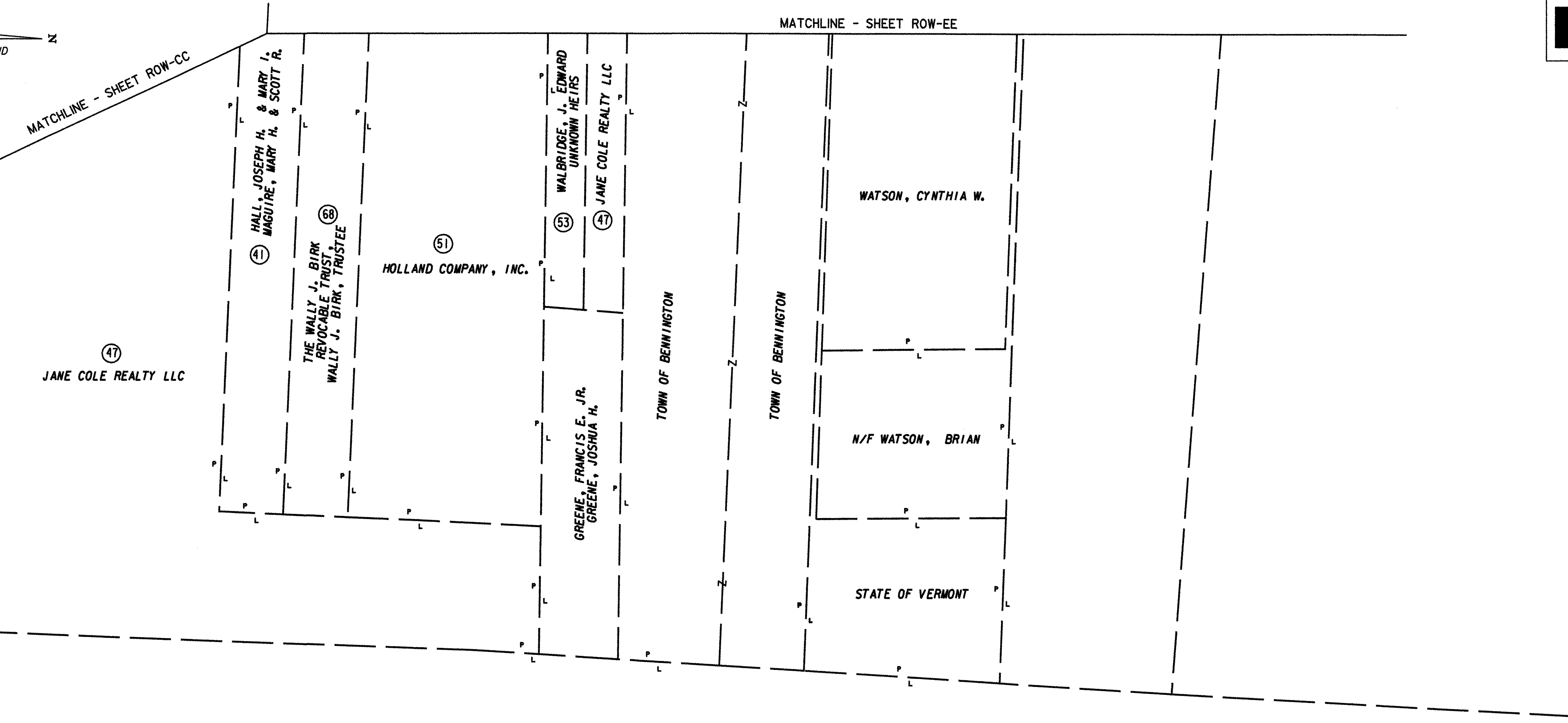

LINES SHOWN ON THIS PLAN AS EXISTING PROPERTY LINES P/L ARE BELIEVED TO BE ACCURATE BUT SHOULD NOT BE RELIED UPON FOR PURPOSES UNRELATED TO THE STATE OF VERMONT'S ACQUISITION OF LAND AND RIGHTS FOR THIS PROJECT.

THIS SHEET TO BE USED FOR RIGHT-OF-WAY INFORMATION ONLY

DATUM
 VERTICAL NAVD 88
 HORIZONTAL NAD 83 (1992)

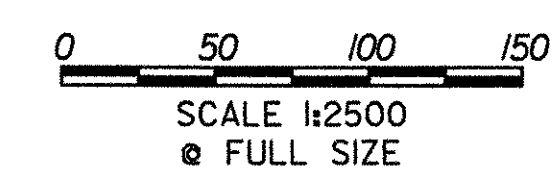

| | | |
|----------------------------------|--|----------------------------------|
| ROW PLAN ROW-DD | PROJECT NAME: BENNINGTON BYPASS | PROJECT NUMBER: NH F019-1(5) |
| | DESIGN FILE NAME: c:\dh\bennington\row | PLOT DATE: 3-26-07 |
| | PROJECT LEADER: JDP | DRAWN BY: ADM CHECKED BY: GAK |
| | | SHEET: 109 OF 112 |

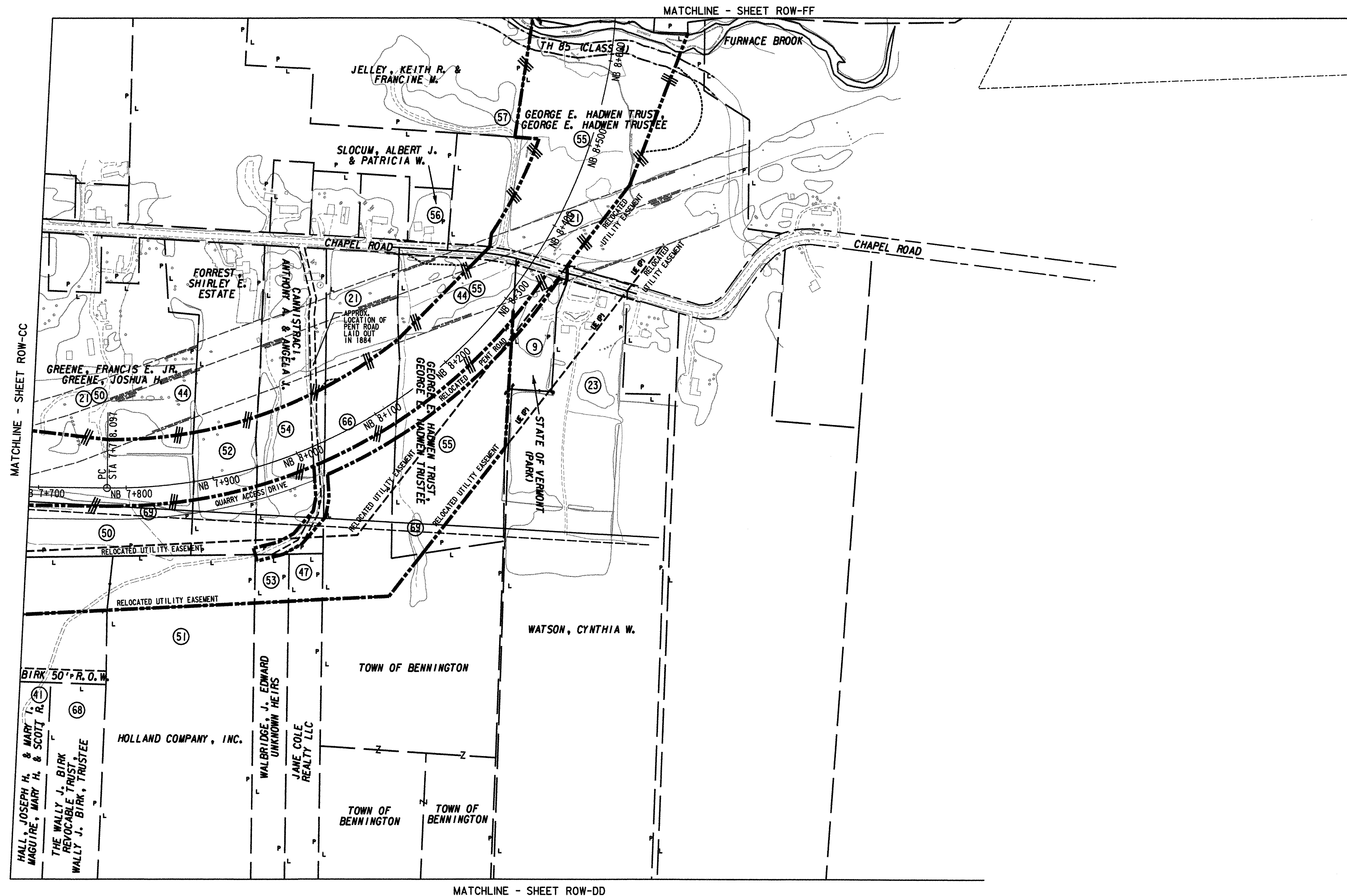

LINES SHOWN ON THIS PLAN AS EXISTING PROPERTY LINES P/L ARE BELIEVED TO BE ACCURATE BUT SHOULD NOT BE RELIED UPON FOR PURPOSES UNRELATED TO THE STATE OF VERMONT'S ACQUISITION OF LAND AND RIGHTS FOR THIS PROJECT.

THIS SHEET TO BE USED FOR RIGHT-OF-WAY INFORMATION ONLY

DATUM
 VERTICAL NAVD 88
 HORIZONTAL NAD 83 (1992)

0 50 100 150
 SCALE 1:2500
 @ FULL SIZE

| | | |
|----------------------------------|--|----------------------------------|
| ROW PLAN ROW-EE | PROJECT NAME: BENNINGTON BYPASS | PROJECT NUMBER: NH F019-K(5) |
| | DESIGN FILE NAME: c:\dh\bennington\row | PLOT DATE: 3-26-07 |
| | PROJECT LEADER: JDP | DRAWN BY: ADM CHECKED BY: GAK |
| | | SHEET: 110 OF 112 |

MATCHLINE - SHEET ROW-GG

PARCELS "AA", "BB" & "CC" PURCHASED UNDER F 019-1 (6)
 PARCELS "101", "102", "103", "104" & "105" PURCHASED UNDER
 PROJECT D.P.I. 0146 (1)

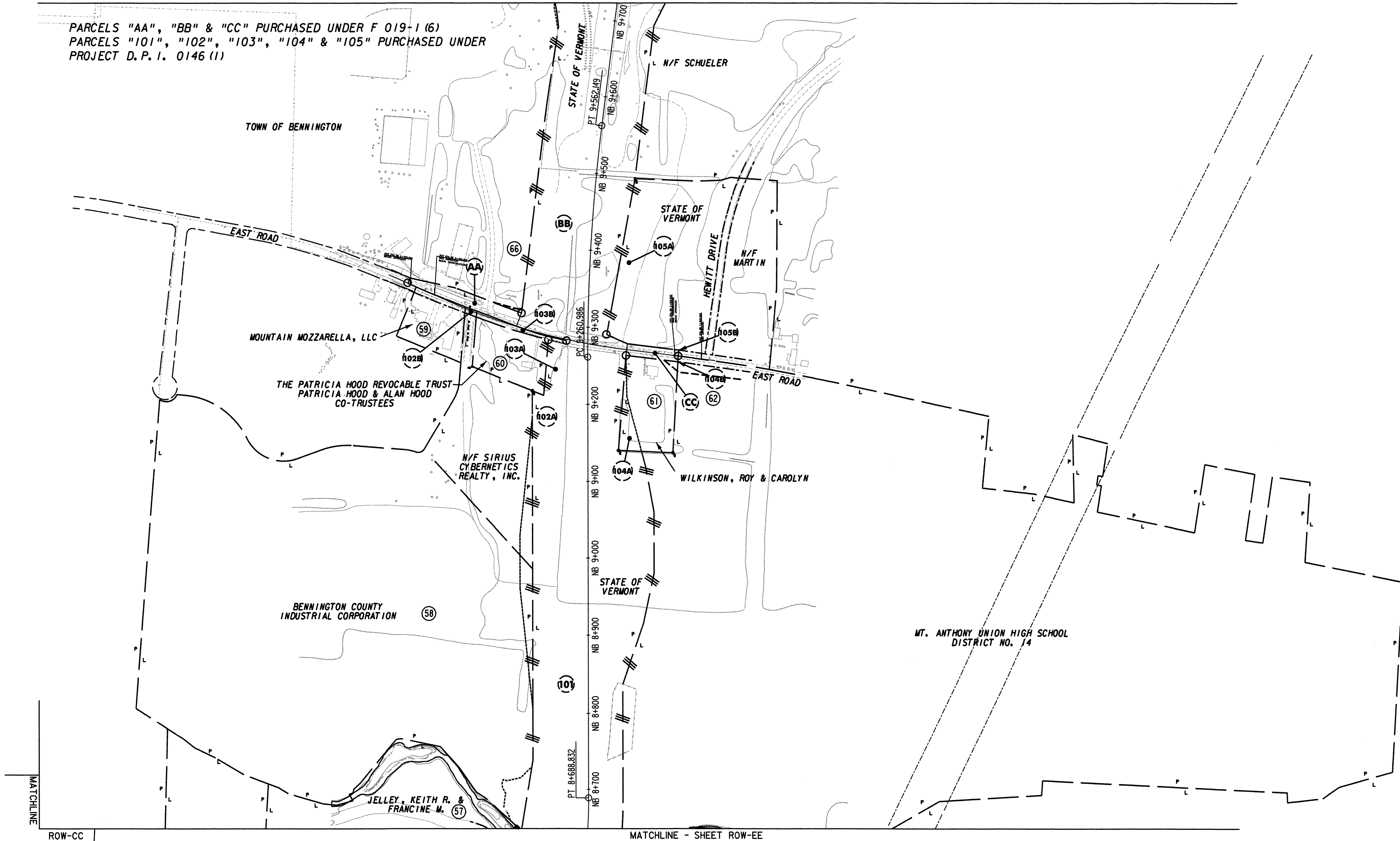

MATCHLINE

ROW-CC

MATCHLINE - SHEET ROW-EE

DATUM
 VERTICAL NAVD 88
 HORIZONTAL NAD 83 (1992)

LINES SHOWN ON THIS PLAN AS EXISTING
 PROPERTY LINES P/L ARE BELIEVED TO
 BE ACCURATE BUT SHOULD NOT BE RELIED
 UPON FOR PURPOSES UNRELATED TO THE
 STATE OF VERMONT'S ACQUISITION OF LAND
 AND RIGHTS FOR THIS PROJECT.

THIS SHEET TO BE USED
 FOR RIGHT-OF-WAY
 INFORMATION ONLY

0 50 100 150
 SCALE 1:2500
 @ FULL SIZE

| | | |
|--------------------------------|--|----------------------------------|
| ROW PLAN ROW-FF | PROJECT NAME: BENNINGTON BYPASS | PROJECT NUMBER: NH F019-1(5) |
| | DESIGN FILE NAME: c:\dh\bennington\row | PLOT DATE: 4-14-06 |
| | PROJECT LEADER: JDP | DRAWN BY: ADM CHECKED BY: GAK |
| | | SHEET: 111 OF 112 |

STA. NB 10+776.00
END PROJECT NH F019-1(5)

END R.O.W. PROJECT
STA. NB 10+558.86
105.45 m (345.96') LT

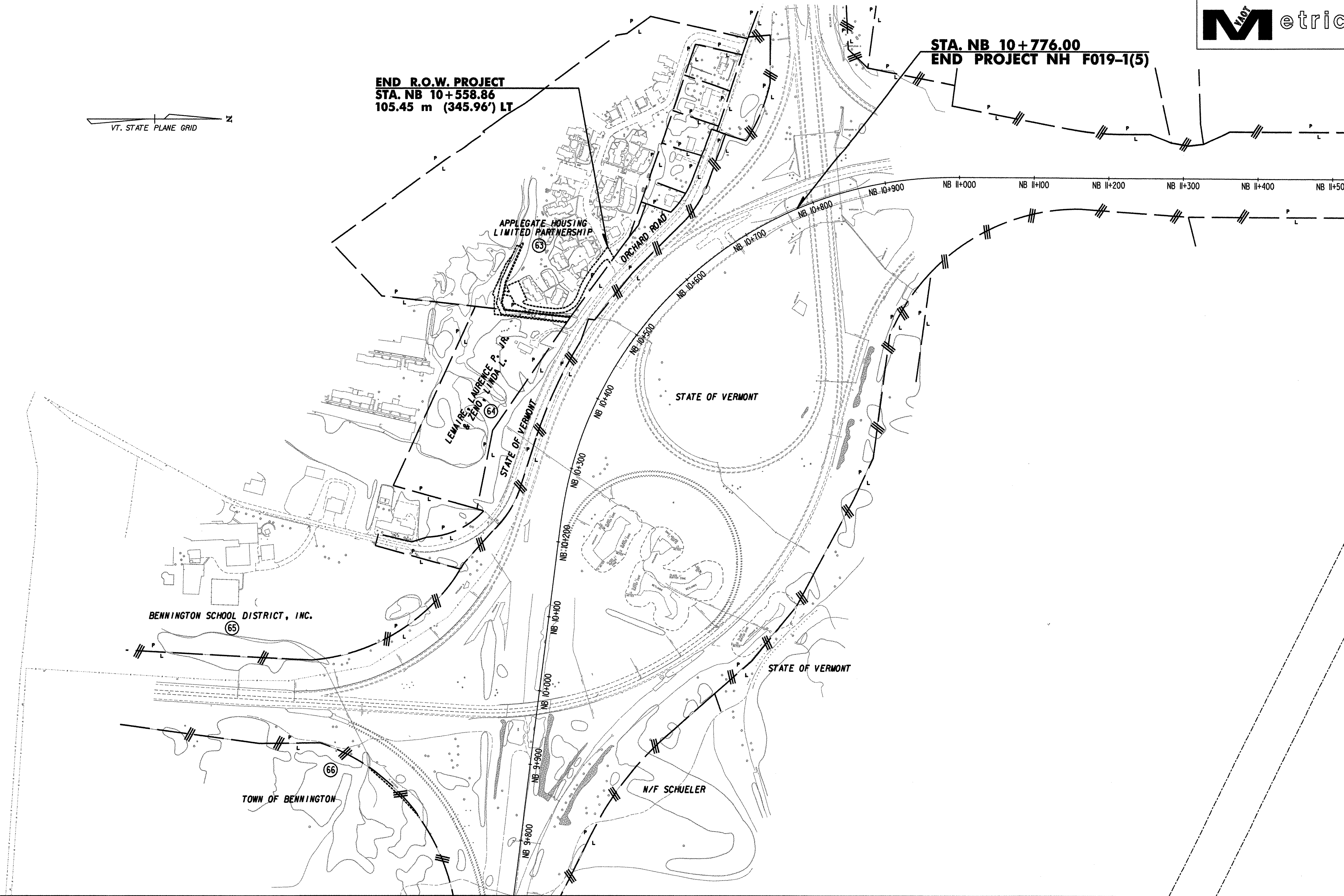

MATCHLINE - SHEET ROW-FF

DATUM
VERTICAL NAVD 88
HORIZONTAL NAD 83 (1992)

LINES SHOWN ON THIS PLAN AS EXISTING PROPERTY LINES P/L ARE BELIEVED TO BE ACCURATE BUT SHOULD NOT BE RELIED UPON FOR PURPOSES UNRELATED TO THE STATE OF VERMONT'S ACQUISITION OF LAND AND RIGHTS FOR THIS PROJECT.

THIS SHEET TO BE USED FOR RIGHT-OF-WAY INFORMATION ONLY

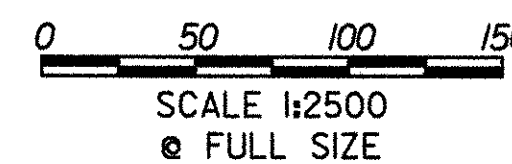

ROW PLAN
ROW-GG

PROJECT NAME: BENNINGTON BYPASS
DESIGN FILE NAME: g:\nh\bennington\row
PROJECT LEADER: JDP

PROJECT NUMBER: NH F019-1(5)

PLOT DATE: 3-26-07
DRAWN BY: ADM
CHECKED BY: GAK

SHEET: 112 OF 112