

TEMPORARY 4in YELLOW LINE (PAINT)
4in YELLOW LINE
STA 175+30 TO 185+00
(WITH CENTERLINE BREAKS FOR TOWN HIGHWAYS)

TEMPORARY 4in WHITE LINE (PAINT)
4in WHITE LINE
STA 175+30 TO 185+00
SOLID LT&RT
STA 175+30 TO 176+00
STA 176+00 TO 177+45
(WITH EDGELINE BREAKS FOR TOWN HIGHWAYS)

LETTER OR SYMBOL
STA 175+52 LT
STA 175+92 LT
STA 179+76 LT
STA 180+16 LT
"ONLY"
"AHEAD"
"SIGNAL"

TEMPORARY LETTER OR SYMBOL (PAINT)
STA 175+52 LT
STA 179+76 LT
STA 180+16 LT
"AHEAD"
"SIGNAL"

ADJUST ELEVATION OF GAS VALVES
(WORK TO BE DONE BY OTHERS)
STA 176+60 RT

CHANGE ELEVATION OF SEWER MANHOLE
(WORK TO BE DONE BY OTHERS)
STA 184+70 LT

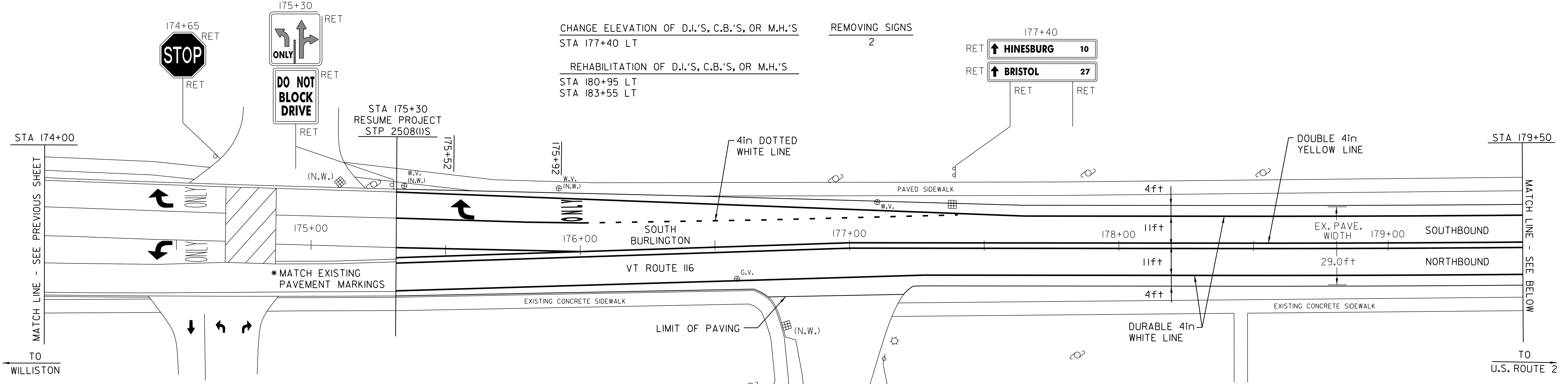

REMOVAL AND DISPOSAL OF GUIDE POSTS
STA 183+85 RT - 2

ANCHOR FOR STEEL BEAM RAIL
STA 183+35 RT
STA 184+85 RT

STEEL BEAM GUARD RAIL, GALVANIZED
STA 183+35 TO 184+85 RT

177+15 B-T-O-B
RET WINDING BROOK DR RET
RET WINDING BROOK DR RET

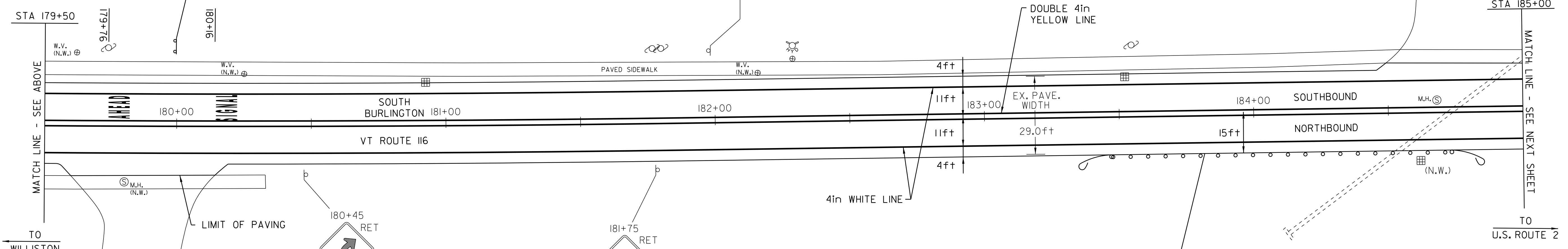
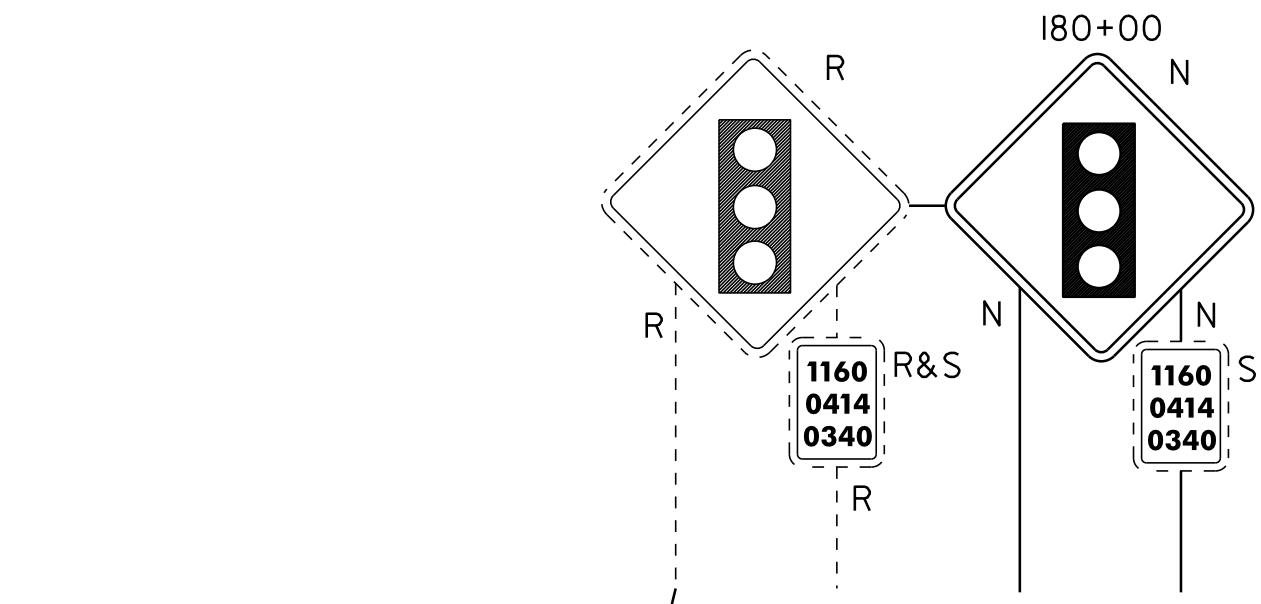

STA 183+85 RT
REMOVAL AND DISPOSAL OF GUIDE POSTS

STA 183+35 RT
INSTALL ANCHOR FOR STEEL BEAM RAIL

STA 183+35 TO 184+85 RT
INSTALL STEEL BEAM GUARD RAIL, GALVANIZED

STA 184+85 RT
INSTALL ANCHOR FOR STEEL BEAM RAIL

- LEGEND
- N = NEW
 - R = REMOVE
 - R&S = REMOVE & SALVAGE
 - S = SALVAGE
 - RET = RETAIN
 - B-T-O-B = BACK TO BACK
 - ⊕ ⊞ ⊠ = CATCH BASIN/DI
 - (N.W.) = NO WORK REQUIRED (TYP. FOR D.I.'S, & C.B.'S WHERE NOTED)
 - ⊙ = YIELDING MARKER POST
 - ⊕ = UTILITY POLE
 - = DRIVE

PAVING PROJECT LAYOUT SHEET #16

DESIGNED BY BCE/PJM DATE 10-06

DRAWN BY C.E.A., INC. DATE 10-06

DESIGN FILE NO. p05b052.dgn

PRF FILE p05b052lcl6 DATE PLOTTED 03-MAY-2012 17

PROJ. NAME **ST. GEORGE-SO. BURLINGTON**

PROJ. NO. **ST-STP 2508(1)S**

SHEET **25** OF **42** SHEETS