

NOTES:  
REFER TO "THE VERMONT STANDARDS & SPECIFICATIONS FOR EROSION PREVENTION & SEDIMENT CONTROL -2006- " FROM THE VT AGENCY OF NATURAL RESOURCES FOR ADDITIONAL GUIDANCE.  
THIS ITEM SHALL BE PAID FOR UNDER ITEM 653.40 INLET PROTECTION DEVICE, TYPE I

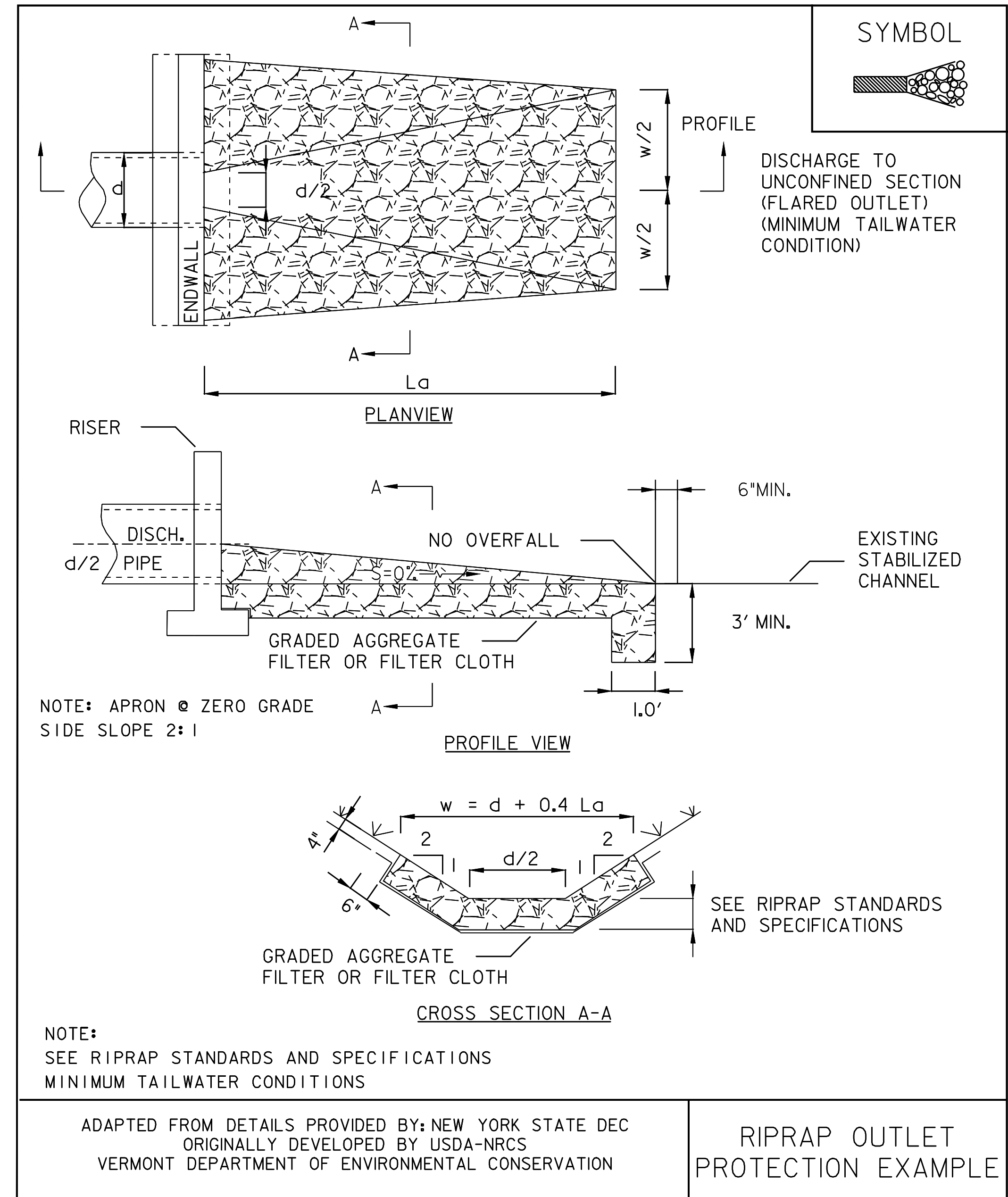

NOTES:  
REFER TO "THE VERMONT STANDARDS & SPECIFICATIONS FOR EROSION PREVENTION & SEDIMENT CONTROL -2006- " FROM THE VT AGENCY OF NATURAL RESOURCES FOR ADDITIONAL GUIDANCE. THIS ITEM SHALL BE PAID FOR UNDER THE APPLICABLE STONE FILL ITEM(S) AS SHOWN ON THE ITEM DETAIL & DRAINAGE SUMMARY SHEET.

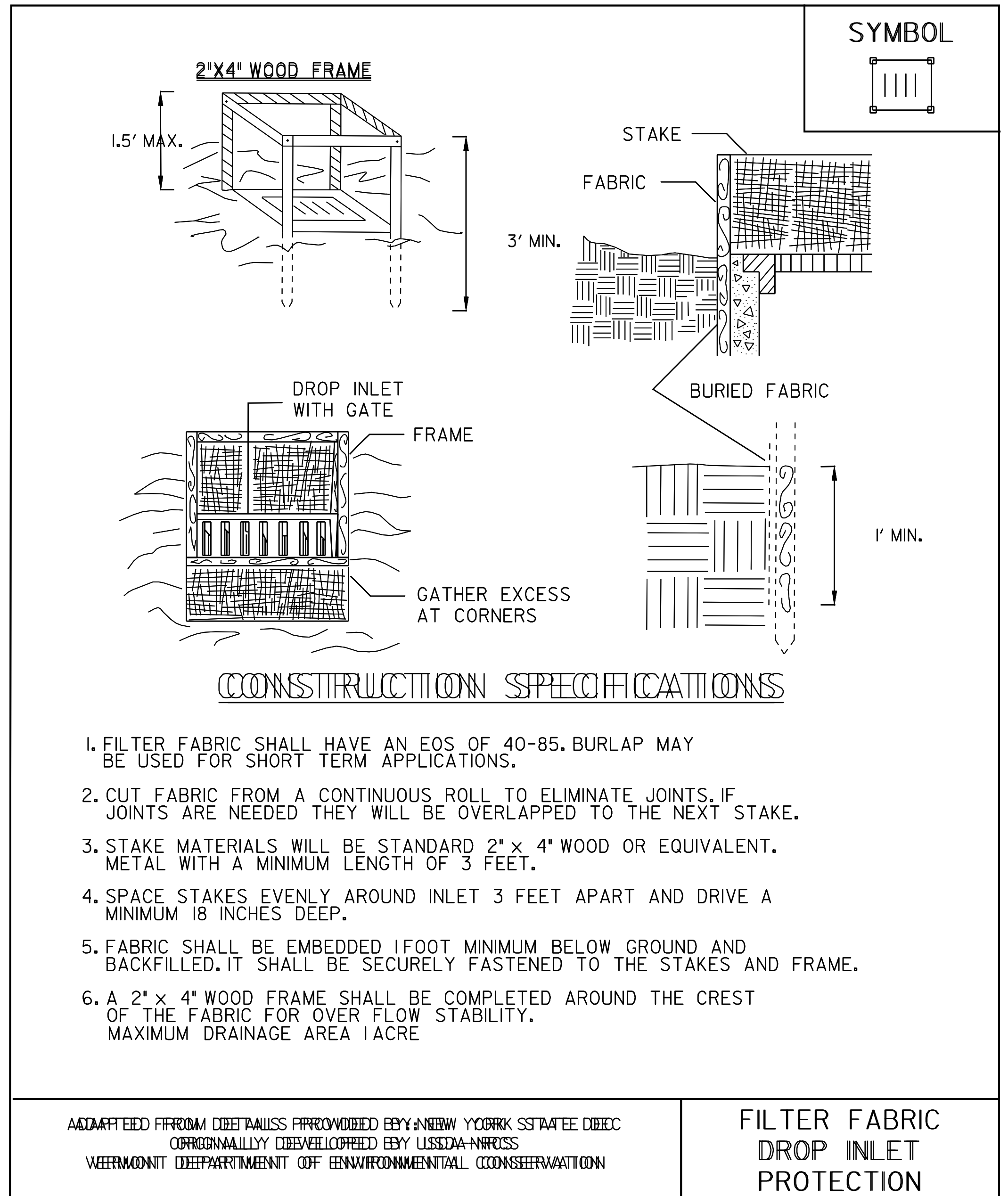

NOTES:  
REFER TO "THE VERMONT STANDARDS & SPECIFICATIONS FOR EROSION PREVENTION & SEDIMENT CONTROL -2006- " FROM THE VT AGENCY OF NATURAL RESOURCES FOR ADDITIONAL GUIDANCE.  
THIS ITEM SHALL BE PAID FOR UNDER ITEM 653.40 INLET PROTECTION DEVICE, TYPE I