

COLOR: BLACK BORDER & LEGEND (REFLECTORIZED)  
YELLOW BACKGROUND (REFLECTORIZED)

MATERIAL: PER VAOT STANDARD E-151

LOCATION: U.S. ROUTE 4  
BRIDGEWATER:  
STA. 10+28.0, LT

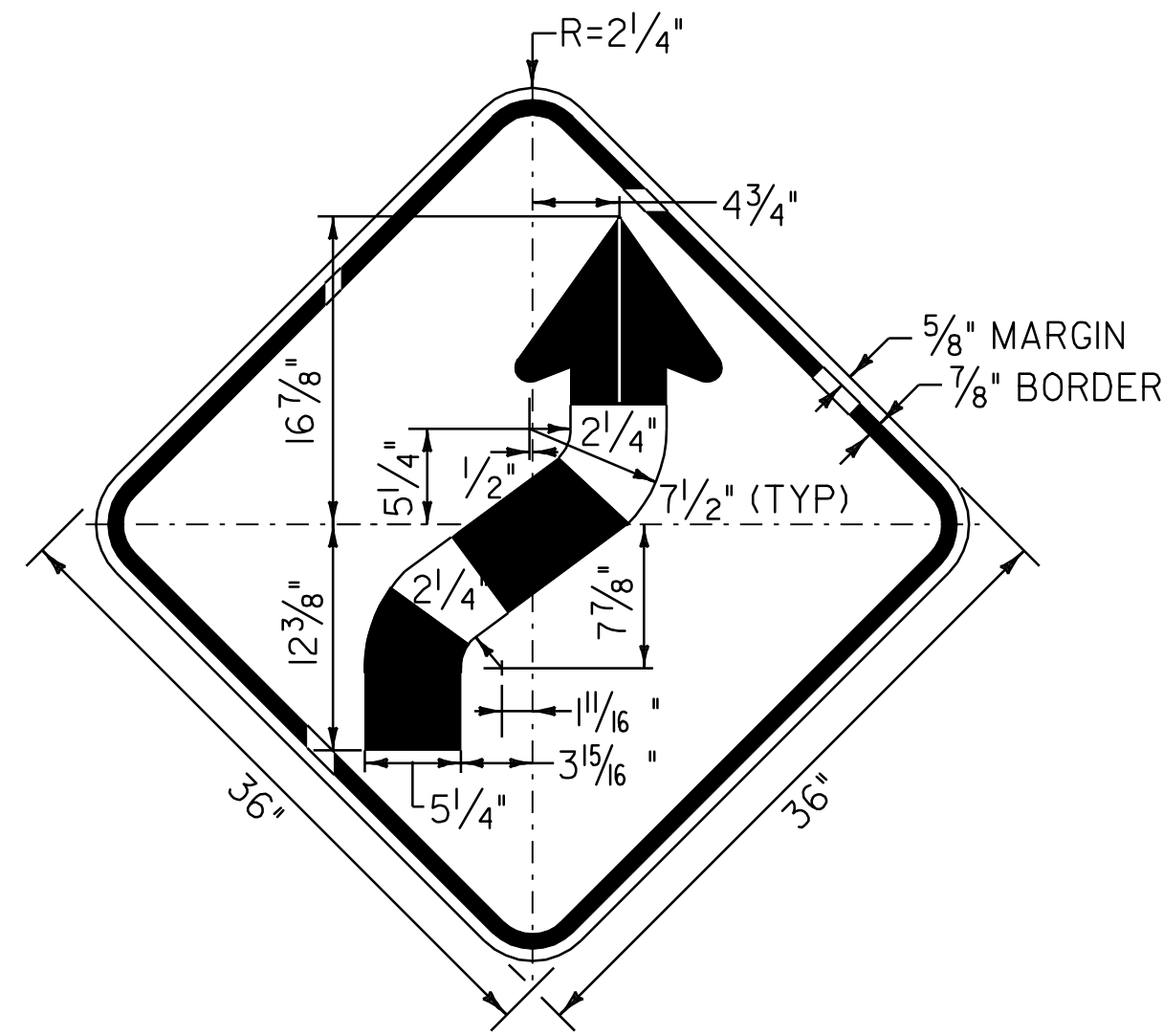

COLOR: BLACK BORDER & LEGEND (REFLECTORIZED)  
YELLOW BACKGROUND (REFLECTORIZED)

MATERIAL: PER VAOT STANDARD E-151

LOCATION: U.S. ROUTE 4  
BRIDGEWATER:  
STA. 316+46.0, RT

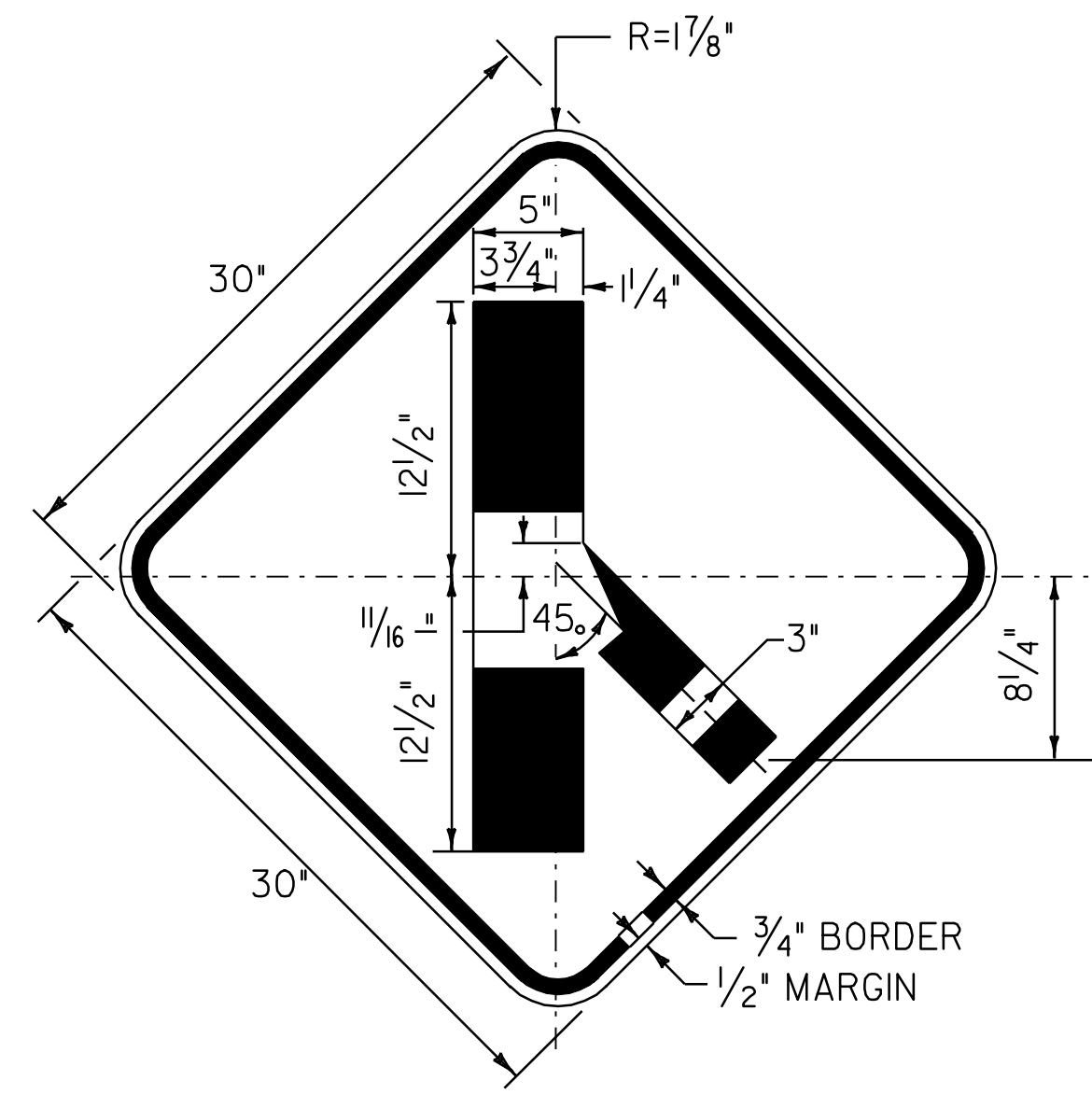

COLOR: BLACK BORDER & LEGEND (REFLECTORIZED)  
YELLOW BACKGROUND (REFLECTORIZED)

MATERIAL: PER VAOT STANDARD E-155

LOCATION: U.S. ROUTE 4  
BRIDGEWATER:  
STA. 88+30.0, RT

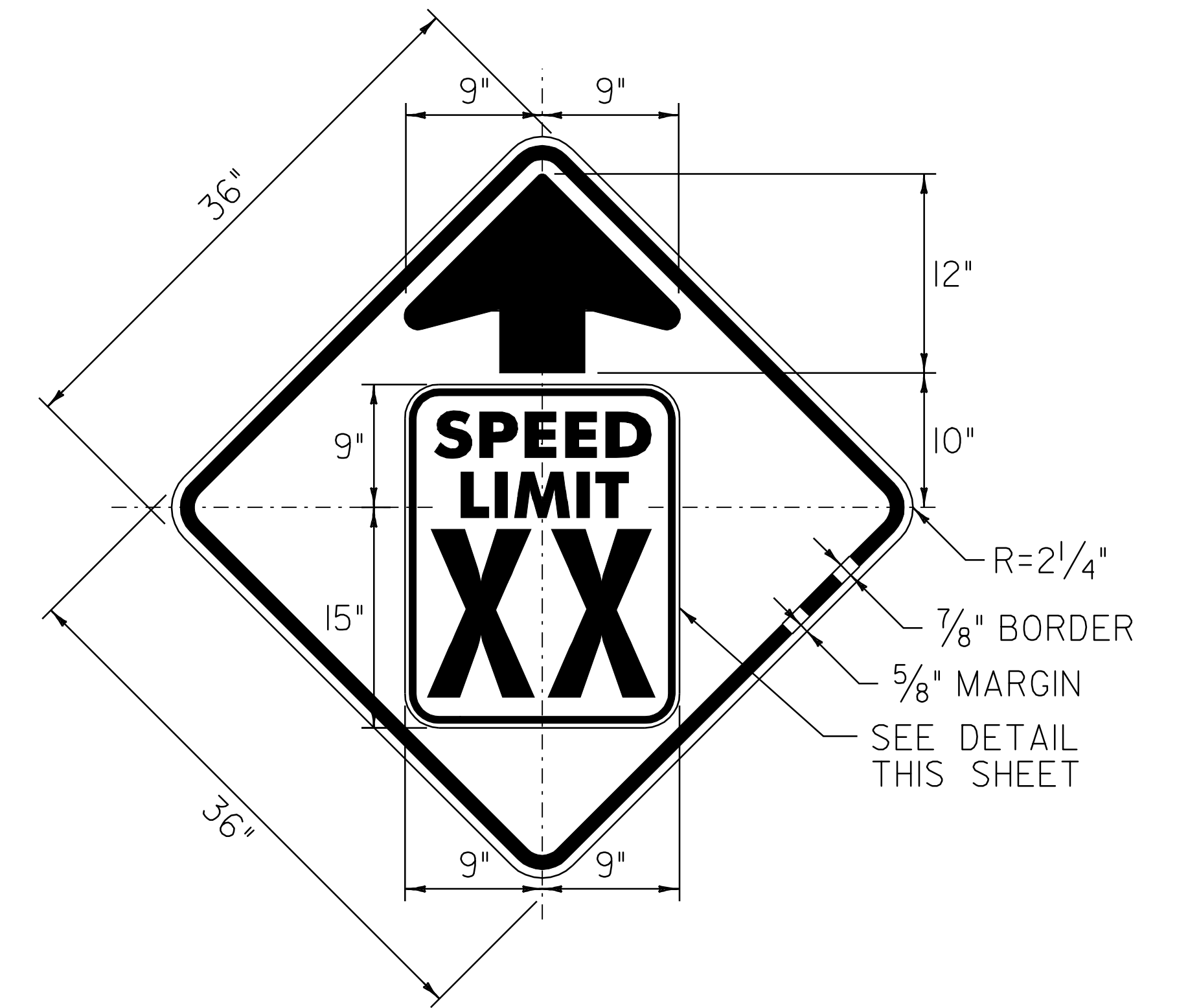

COLOR: BLACK BORDER & LEGEND (REFLECTORIZED)  
YELLOW BACKGROUND (REFLECTORIZED)

MATERIAL: PER VAOT STANDARD E-151

LOCATION: U.S. ROUTE 4  
BRIDGEWATER  
STA. 285+47.0, RT

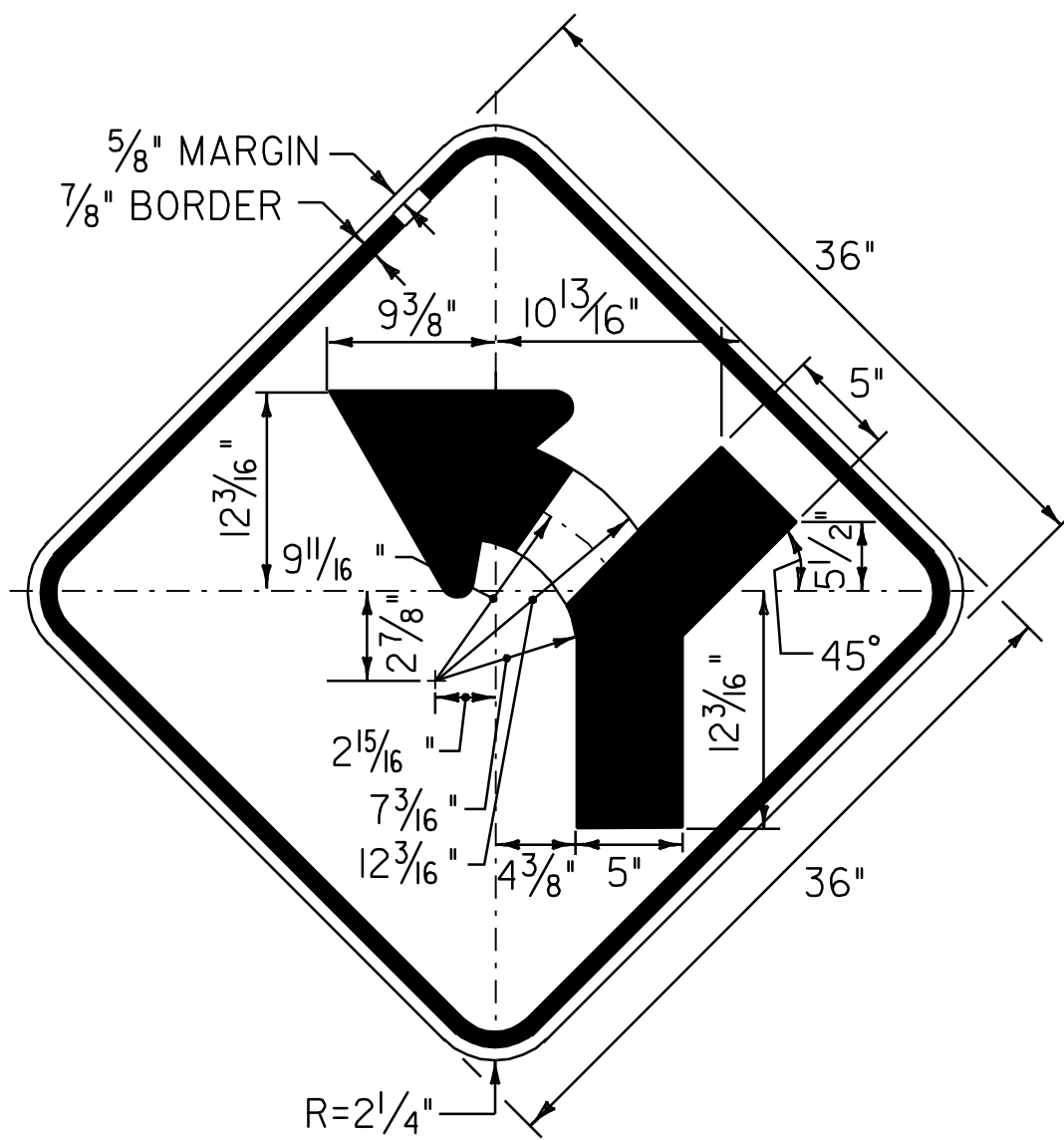

COLOR: BLACK BORDER & LEGEND (REFLECTORIZED)  
YELLOW BACKGROUND (REFLECTORIZED)

MATERIAL: PER VAOT STANDARD E-151

LOCATIONS: U.S. ROUTE 4  
KILLINGTON:  
STA. 440+54.0, RT

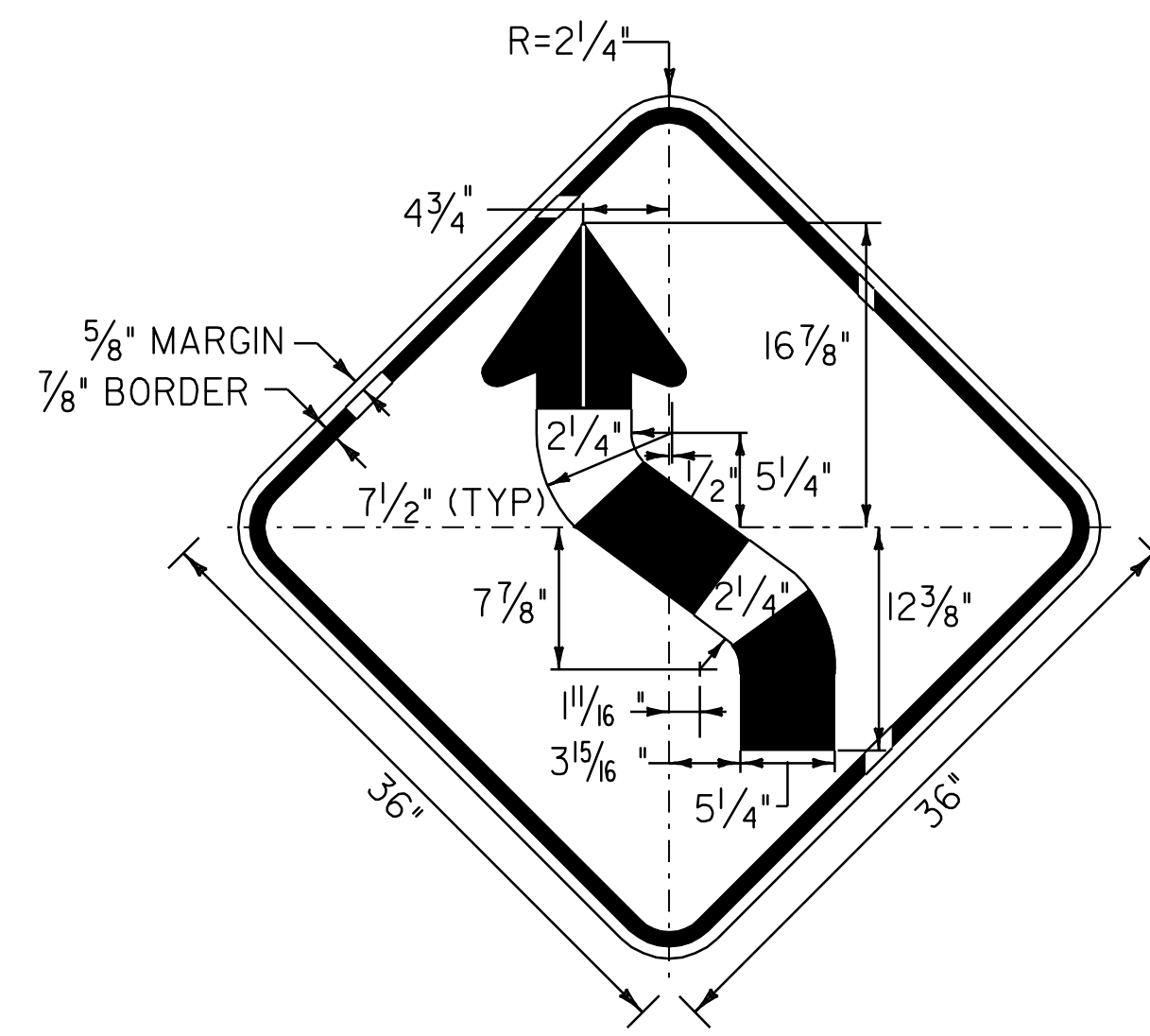

COLOR: BLACK BORDER & LEGEND (REFLECTORIZED)  
YELLOW BACKGROUND (REFLECTORIZED)

MATERIAL: PER VAOT STANDARD E-151

LOCATIONS: U.S. ROUTE 4  
BRIDGEWATER:  
STA. 80+00.0, RT  
STA. 115+11.0, LT

**NOTE:**

TEXT LAYOUT DIMENSIONS ARE BASED ON THE STANDARD ALPHABETS SPACING CHARTS FOUND IN THE "STANDARD HIGHWAY SIGNS" BOOK PUBLISHED BY FHWA. MINOR VARIATIONS IN TEXT DIMENSIONS ARE ACCEPTABLE BASED ON INDIVIDUAL MANUFACTURER'S LETTER FABRICATION. SIGNIFICANT CHANGES THAT AFFECT SIGN APPEARANCE SHALL BE BROUGHT TO THE ATTENTION OF THE VAOT'S TRAFFIC OPERATIONS SECTION BEFORE FABRICATION.

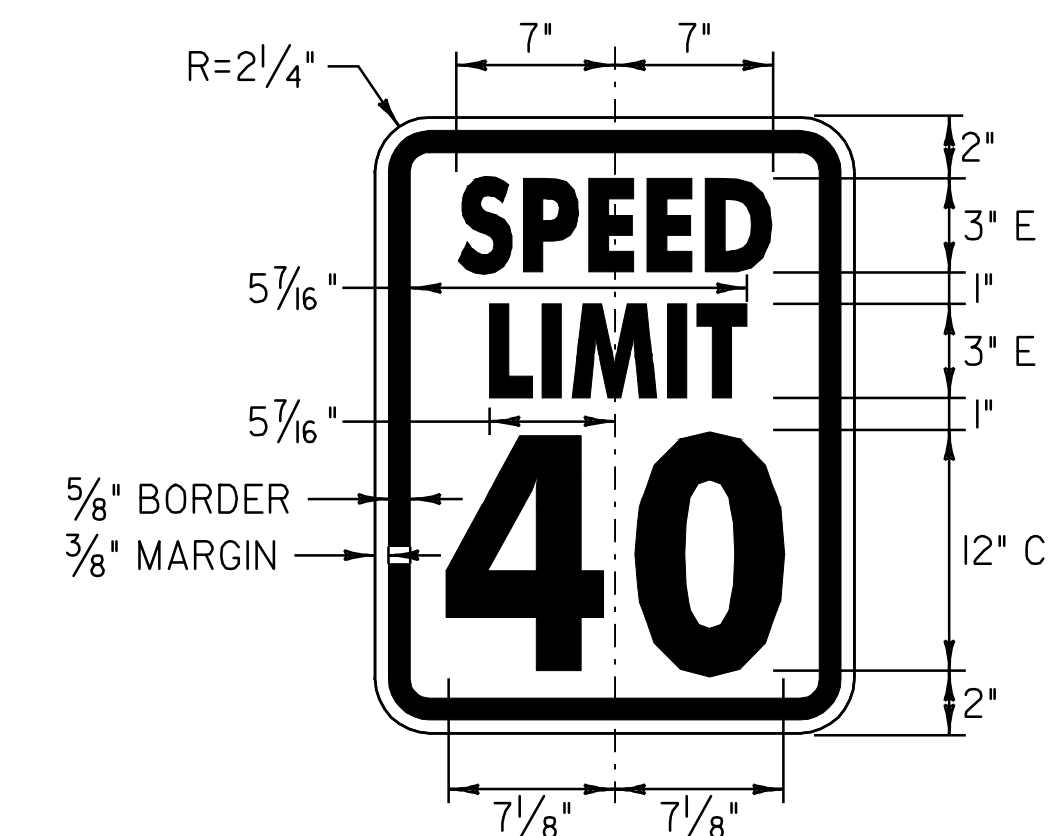

COLOR: BLACK BORDER & TEXT (REFLECTORIZED)  
WHITE BACKGROUND (REFLECTORIZED)

**NOT TO SCALE**

**TRAFFIC SIGN  
DETAIL  
SHEET**

PROJECT NAME: KILLINGTON - BRIDGEWATER  
PROJECT NUMBER: NH 2502(1)S

FILE NAME: p05b036.dgn  
PROJECT LEADER: D.E.G.  
DESIGNED BY: J.S.P.  
IPARM FILE: p05b036+sd01.i

PLOT DATE: 15-MAY-2008 14  
DRAWN BY: C.A.K.  
CHECKED BY: D.E.G.  
SHEET 62 OF 74