

Typical Connection Detail

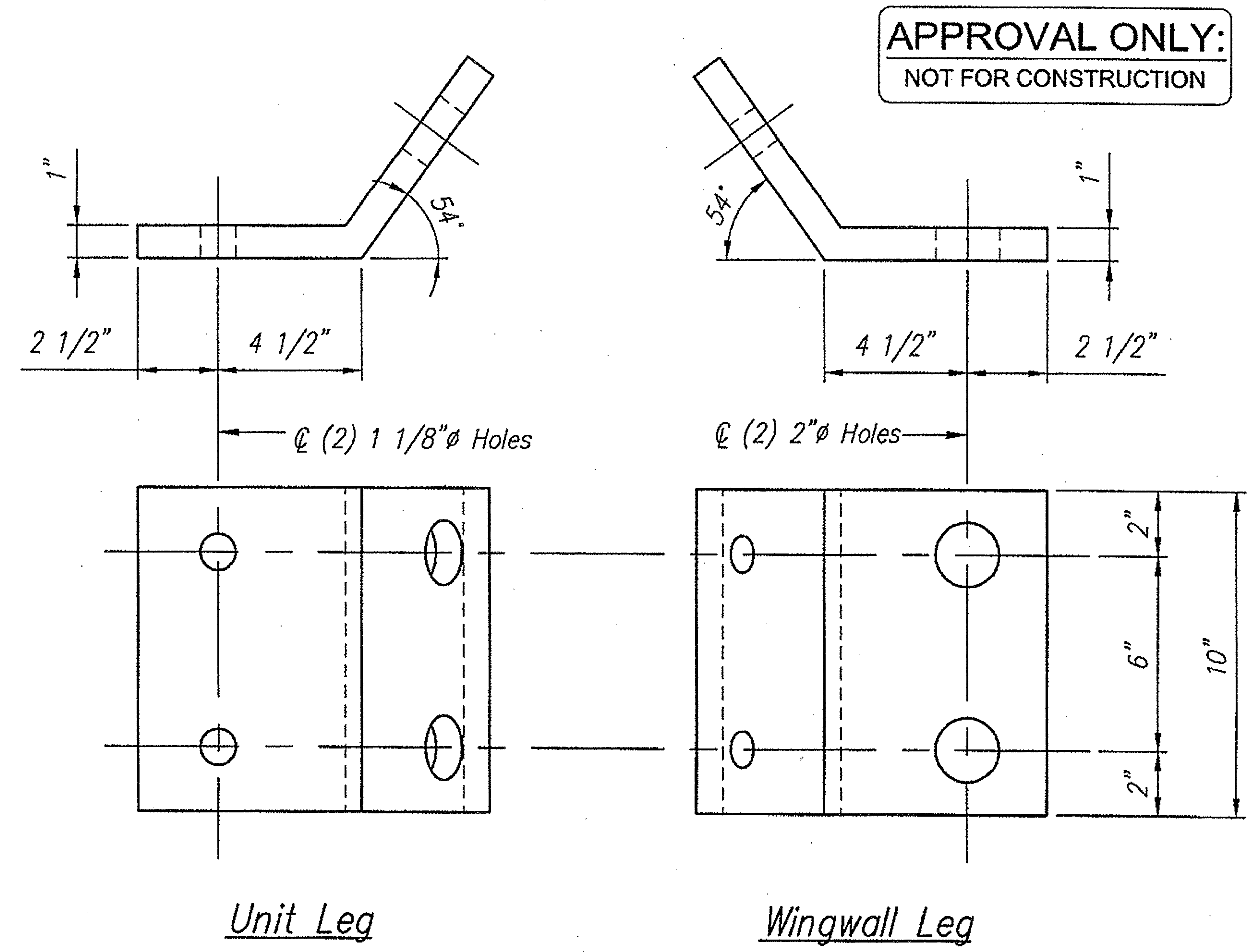

P-2
(P, 1" x 10" x 14")
(Galvanized as per ASTM A153)

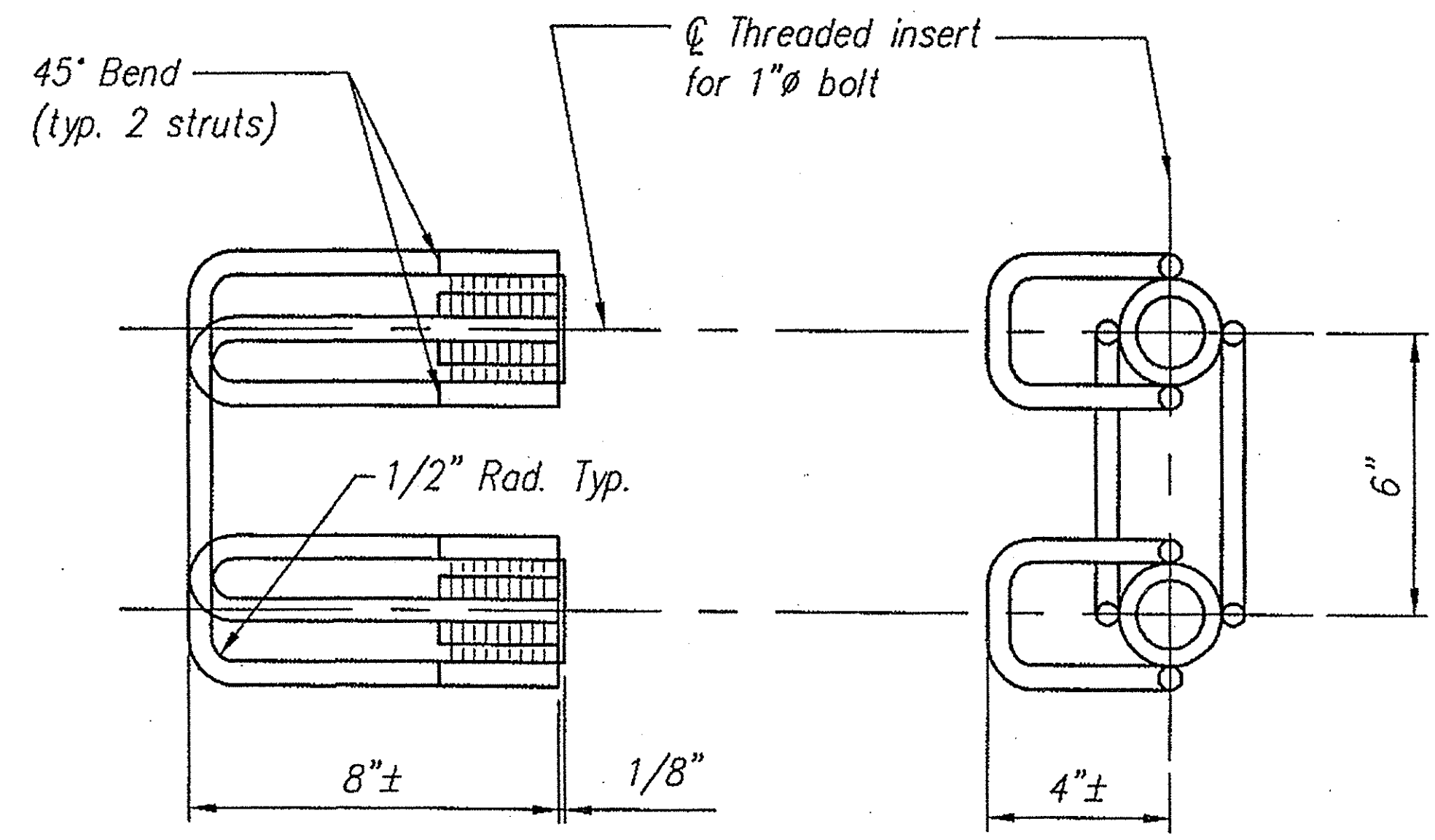

Dayton/Richmond Two Bolt Preset Anchor

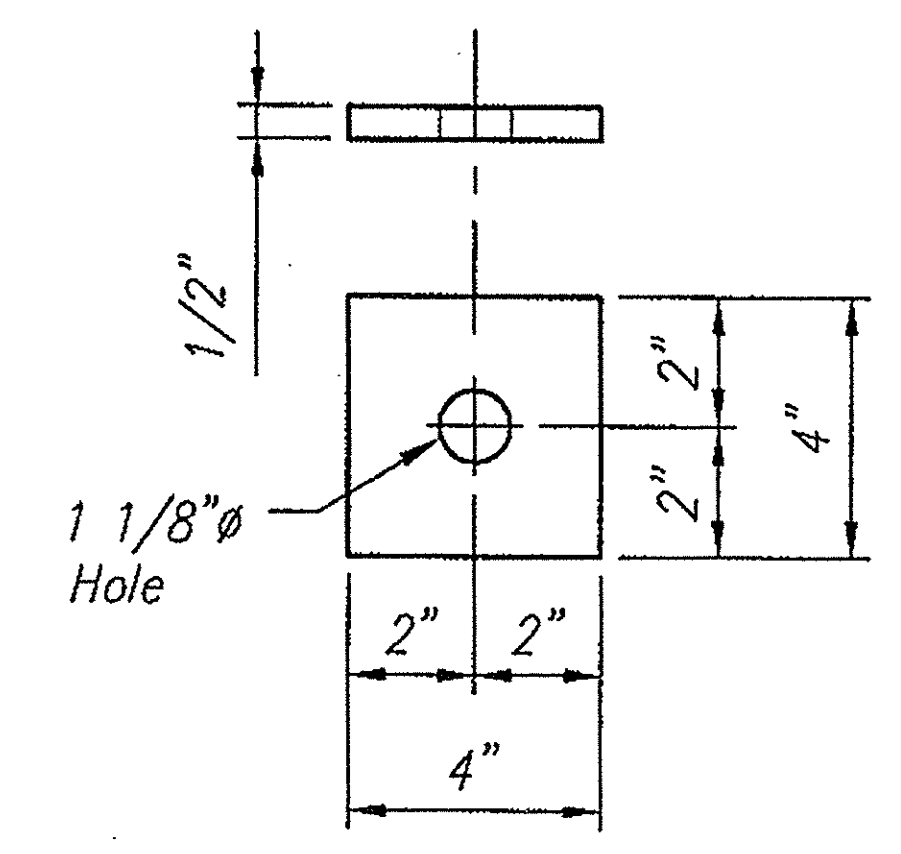

(P washer, 1/2" x 4" x 4")
(Galvanized as per ASTM A153)

PLATE P-2	
Total Required = 2	(4) PW-1 Req'd. per Plate

CONSPAN
BRIDGE SYSTEMS
3100 Research Blvd.
P.O. Box 20266
Dayton, Ohio 45420-0266
(800) 526-3999

Offices
Dayton, OH (937) 254-2233
fax (937) 254-8365
Charlotte NC (704) 548-8420
Sacramento, CA (916) 787-8701
Albany, NY (518) 371-2871

CON/SPAN® is a patented system and the furnishing of this drawing does not constitute an express or implied license.

Revisions:	
No.	Date
1	
2	
3	
4	

Sheet Title:
WINGWALL CONNECTION PLATE
SHOP DRAWING

VERMONT
MONTPELIER
BUELS GORE

Des. By: KJG	Job No. 14688
Drawn By: WLC	Sheet No.
Chk'd By: MRW	S23
Date: 8/25/06	060