

ADJUST ELEVATION OF VALVE BOX  
 STA. 153+45 RT (WSO-3 EA)

DURABLE AND TEMPORARY 4'' WHITE LINE  
 STA. 150+00 - STA. 160+00 LT & RT (EDGE LINE)

DURABLE AND TEMPORARY 4'' YELLOW LINE  
 STA. 150+00 - STA. 160+00 LT & RT (DOUBLE YELLOW CL)

REMOVAL AND DISPOSAL OF GUARD RAIL  
 STA. 150+00 - STA. 156+50 LT

STEEL BEAM GUARD RAIL (GALVANIZED)  
 STA. 150+00 - STA. 156+75 LT

ANCHOR FOR STEEL BEAM GUARD RAIL  
 STA. 156+63 LT

CHANGING ELEVATION OF SEWER MANHOLE  
 STA. 153+57 RT (IN PAVED APRON)

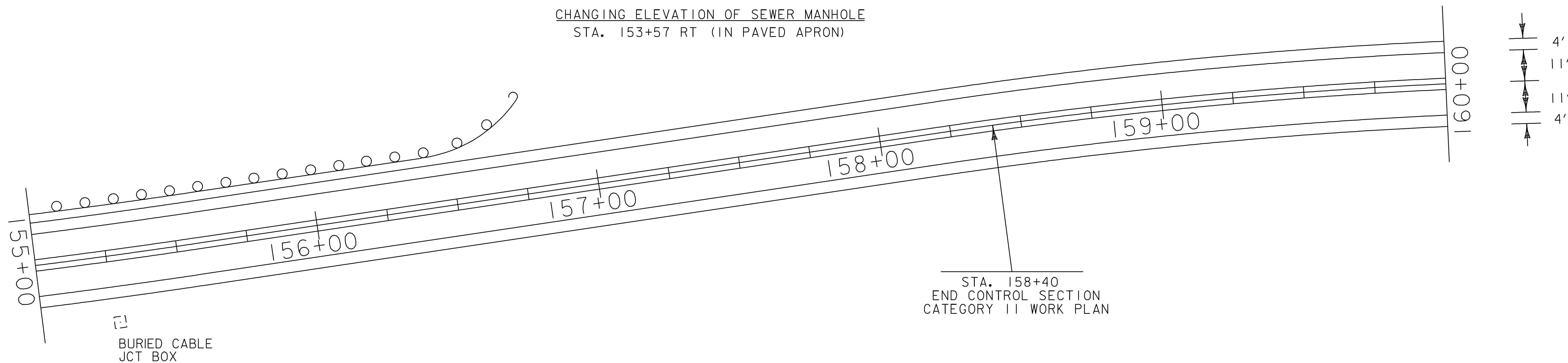

**PAVING  
 PROJECT  
 LAYOUT  
 #17**

PROJECT NAME: STOWE  
 PROJECT NUMBER: AC STP 2407(I)S

FILE NAME: p04c048.dgn  
 PROJECT LEADER: WOOLAVER  
 DESIGNED BY: LOCKE  
 p04c048I17.1

PLOT DATE: 11-JUN-2007 13:45  
 DRAWN BY: LOCKE  
 CHECKED BY: PAVT MGMT  
 SHEET 26 OF 69