

ELEVATION VIEW

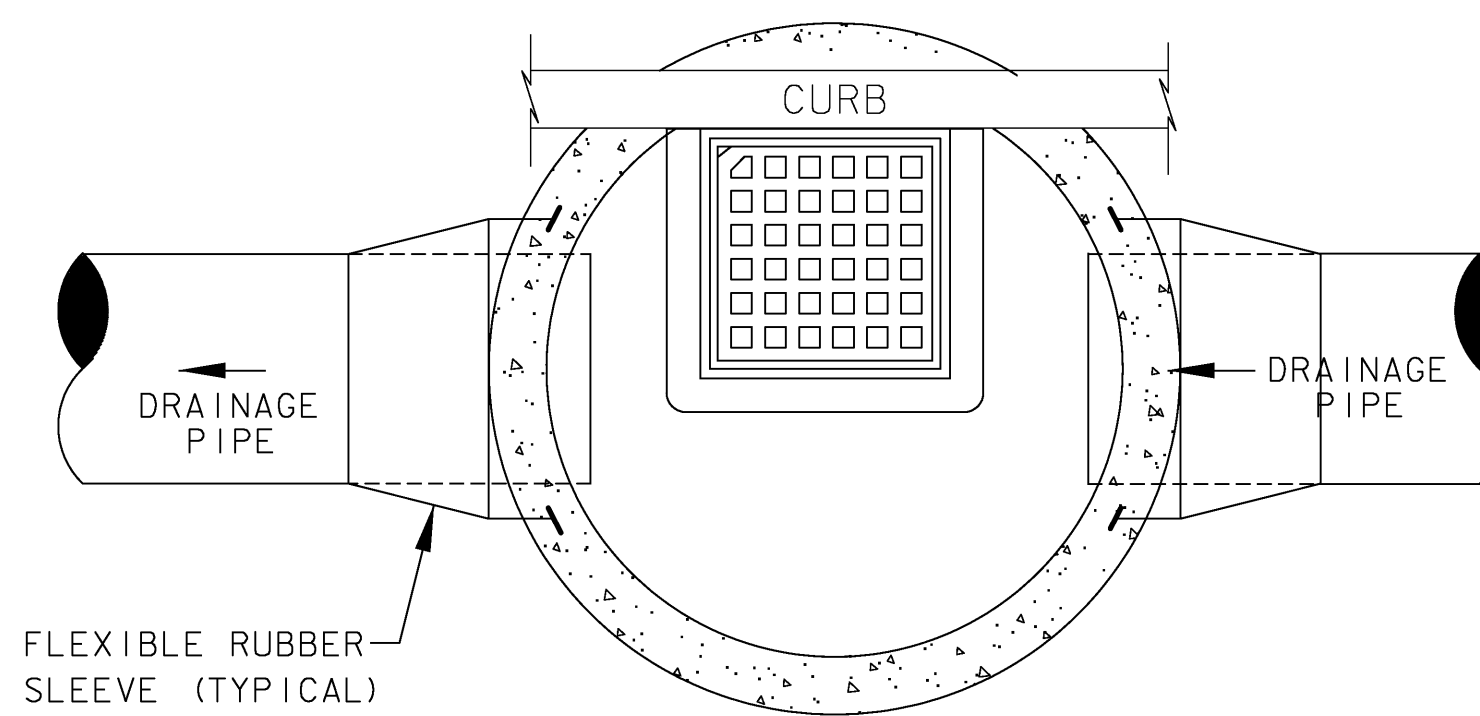

DROP INLET PLAN VIEW

TYPICAL PRECAST DROP INLET INSTALLED IN ROADWAY  
NOT TO SCALE

**PRECAST CONCRETE DROP INLET AND MANHOLE NOTES:**

1. PRECAST CONCRETE SECTIONS SHALL CONFORM TO THE STANDARD SPECIFICATIONS AND ASTM C-478.
2. MINIMUM CONCRETE COMPRESSIVE STRENGTH: 4,000 PSI AT 28-DAYS
3. STEEL REINFORCING SHALL CONFORM TO ASTM A185 OR A82 FOR HS25 LOADING.
4. MANHOLE STEPS SHALL BE 14" WIDE STEEL REINFORCED COPOLYMER POLYPROPYLENE PLASTIC CONFORMING TO ASTM C-478 AND SHALL BE CAST INTO MANHOLE SECTIONS BY THE PRECAST CONCRETE MANUFACTURER.
5. FACE OF PIPE SHALL NOT PROJECT MORE THAN 2" OR LESS THAN 1" FROM INSIDE WALL OF STRUCTURE.
6. ALL STRUCTURES WITH MULTIPLE PIPES SHALL HAVE A MINIMUM OF 12" OF OUTSIDE SURFACE BETWEEN HOLES, NO MORE THAN 75% OF A HORIZONTAL CROSS-SECTION SHALL BE HOLES, AND THERE SHALL BE NO HOLES CLOSER THAN 3" TO JOINTS.
7. FITTING FRAME TO FINAL GRADE MAY BE DONE WITH A SYNTHETIC RISER OR WITH PRECAST CONCRETE GRADE RINGS OF APPROPRIATE THICKNESS (3 COURSES MAX).
8. ALL PIPE INVERTS AND PENETRATION ANGLES SHALL BE FIELD VERIFIED PRIOR TO PRECASTING.
9. PRECAST SECTIONS SHALL HAVE A TONGUE AND GROOVE JOINT AND BE ASSEMBLED USING A BUTYL RUBBER OR APPROVED EQUAL SEALANT.
10. PROVIDE FLEXIBLE RUBBER SLEEVES CONFORMING TO ASTM C-923, RESILIENT, OF SIZE REQUIRED, FOR EACH PIPE CONNECTING TO STRUCTURE. SLEEVES SHALL BE CAST INTO PRECAST STRUCTURE BY THE MANUFACTURER FOR ALL PIPE PENETRATIONS.
11. DROP INLET GRATE ORIENTATION SHALL BE IN ACCORDANCE WITH STANDARD DRAWING D-15 FOR TYPE D GRATES.
12. INSTALLATION OF DROP INLETS OVER EXISTING PIPES SHALL INCLUDE CLEAN CUTTING OF EXISTING PIPES, PROVIDING AN EXTENSION PIPE OF SIMILAR MATERIAL AND SIZE AS THE EXISTING PIPE, COUPLINGS REQUIRED FOR THE CONNECTION BETWEEN THE EXTENSION PIPE AND THE EXISTING PIPE, AND INSTALLING FLEXIBLE RUBBER SLEEVES AS SHOWN IN DETAILS PROVIDED ON THIS SHEET.
13. PAYMENT FOR INSTALLATION OF THE DROP INLETS SHALL BE MADE UNDER THE PRECAST REINFORCED CONC. DROP INLET WITH CAST IRON GRATE (ITEM 604.18).

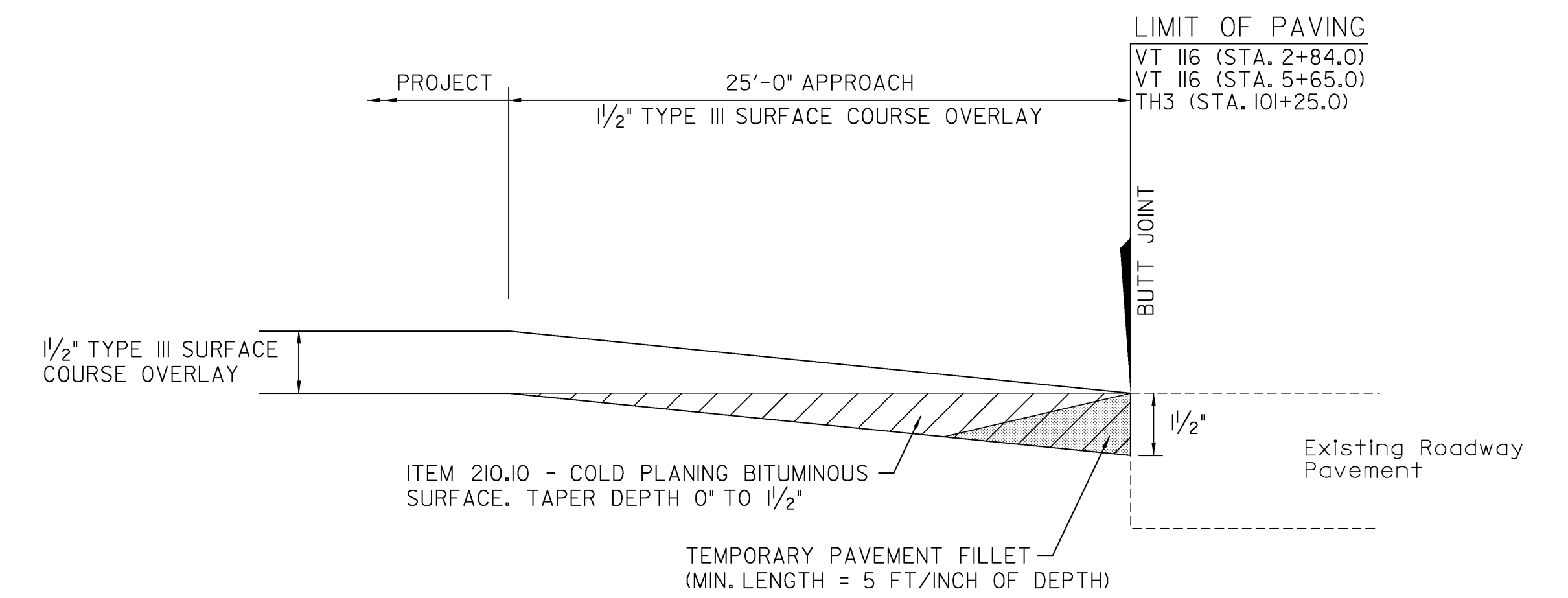

OVERLAY PAVEMENT MATCH TRANSITION DETAIL  
NOT TO SCALE

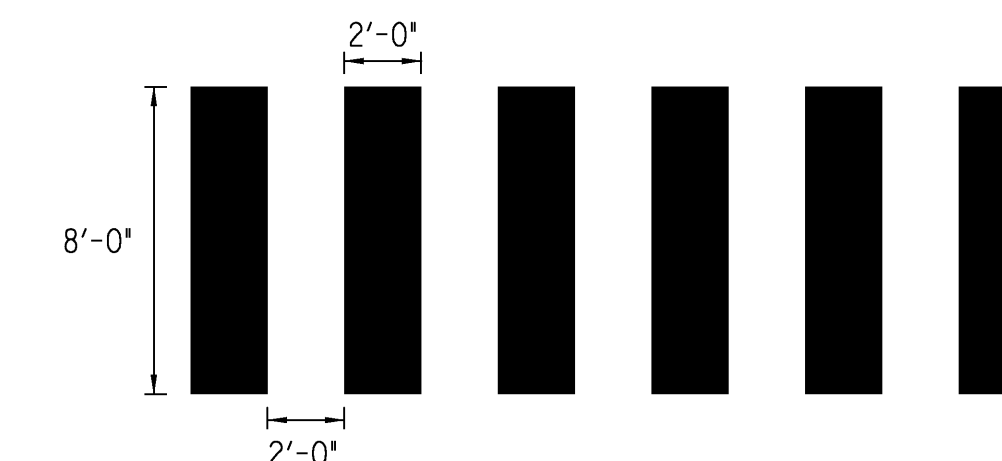

BLOCK STYLE CROSSWALK MARKING DETAIL  
NOT TO SCALE

PROJECT NAME: HINESBURG	FILE NAME: z04bB208det.dgn	PLOT DATE: 5/4/2007
PROJECT NUMBER: HES 021-(121)	PROJECT LEADER: G. BAKOS	DRAWN BY: D. PECK
	DESIGNED BY: D. PECK	CHECKED BY: G. BAKOS
	DETAILS SHEET	SHEET 3 OF 19