

TEMPORARY 4" YELLOW LINE, PAINT
 STA 114+50 TO STA 122+00, SOLID LT & RT
 4" YELLOW LINE
 STA 114+50 TO STA 122+00, SOLID LT & RT
 REMOVING SIGNS
 STA 116+06 RT

STONE FILL, TYPE I
 STA 114+50 TO 115+75 RT

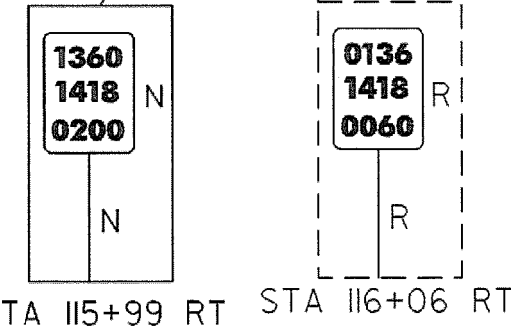
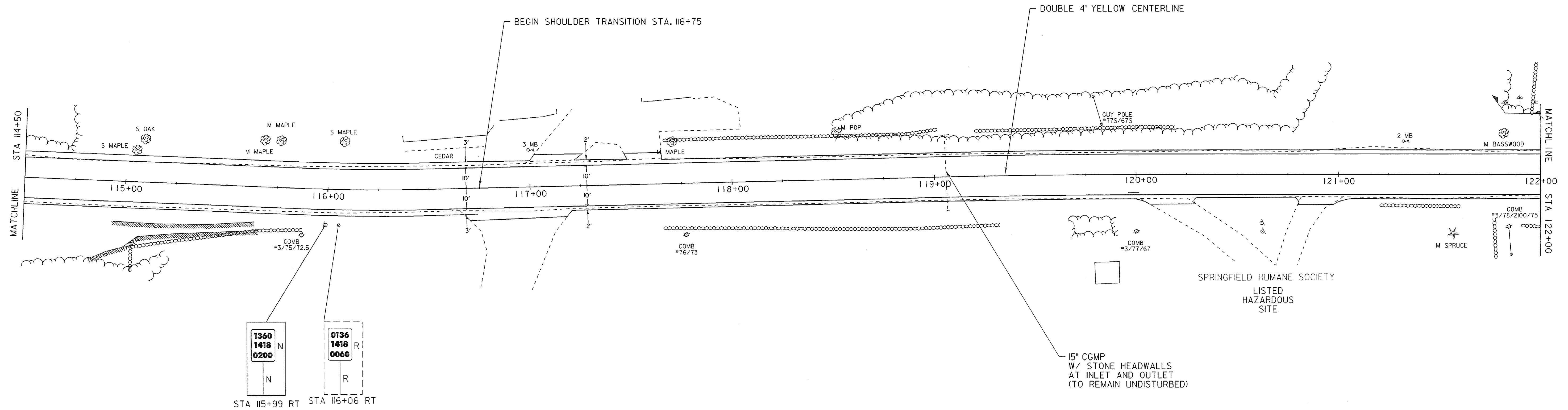
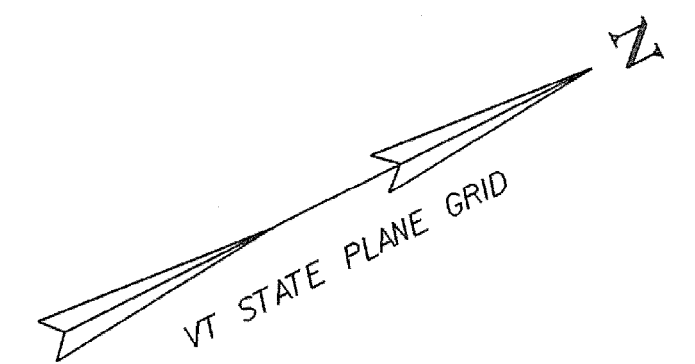

LEGEND	
R	= REMOVE EXISTING
S	= SALVAGE
R&S	= REMOVE & SALVAGE
N	= NEW
RET	= RETAIN
B-B	= BACK TO BACK

NOTES:

- EXISTING SHOULDER MATERIAL ON TOWN HIGHWAYS SHALL BE EXCAVATED TO A DEPTH OF 3' OR AS DIRECTED BY THE RESIDENT ENGINEER. SEE GENERAL NOTE #6 SHEET 3 FOR MORE INFORMATION.
- SEE SHEET 5 & 10 FOR REDUCED STEEL BEAM GUARDRAIL POST SPACING FOR CULVERT AND UTILITY POLE DETAILS.
- WHITE LINES SHOWN ON PLANS IS FOR DISPLAY PURPOSES ONLY.

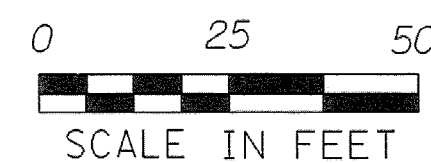

LAYOUT SHEET #8

PROJECT NAME:	SPRINGFIELD
PROJECT NUMBER:	STP 0136(1)
FILE NAME: ...02C084\...02C084_nul.dgn	PLOT DATE: 30-DEC-2008
PROJECT LEADER: K. UPMAL	DRAWN BY: B. KIPPAN, PAPPAS
DESIGNED BY: B. KIPPAN, PAPPAS	CHECKED BY: N. PAPPAS
IPARM FILE NAME: 02c084_lay_08	SHEET 21 OF 68