

HYDRAULIC DATA

1. DRAINAGE AREA	0.19 km ²	
2. CHARACTER OF TERRAIN	HILLY TO MOUNTAINOUS, MOSTLY FORESTED WITH SOME OPEN AREAS	
3. CHARACTER AND TYPE OF STREAM	SINUOUS WITH A MODERATE GRADE, INTERMITTENT	
4. NATURE OF STREAMBED	UNDEFINED CHANNEL, WOODS/GRASS	
Q2.33	0.80 m ³ /s	050 1.42 m ³ /s
Q10	1.10 m ³ /s	0100 1.58 m ³ /s
Q25	1.29 m ³ /s	0500

EXISTING STRUCTURE

1. STRUCTURE TYPE:	CGMP	YEAR BUILT:	
2. CLEAR SPAN (NORMAL TO STREAM):	0.610 m		
3. VERTICAL CLEARANCE ABOVE STREAMBED:	0.610 m		
4. WATERWAY OF FULL OPENING:	0.29 m ²		
5. DISPOSITION OF STRUCTURE:	TO BE REMOVED		
6. TYPE OF MATERIAL UNDER SUBSTRUCTURE:			
7. WATER SURFACE ELEVATION * @	Q2.33=	131.790 m	VELOCITY= 2.80 m/s
	Q10=	133.450 m	= 3.79 m/s
	Q25=	134.480 m	= 4.33 m/s
	Q50=	135.630 m	= 4.86 m/s
	Q100=	136.950 m	= 5.41 m/s

PROPOSED STRUCTURE

1. STRUCTURE TYPE	PRE-CAST BOX CULVERT
2. CLEAR SPAN LENGTH (S):	1.525 m
3. VERTICAL CLEARANCE ABOVE STREAMBED:	0.610 m
4. ARE PROVISIONS TO BE MADE FOR PUBLIC UTILITIES?	NO
HYDRAULIC DATA:	
1. WATERWAY AREA OF FULL OPENING (NORMAL TO STREAM):	0.93 m ²
2. WATER SURFACE ELEVATION * @	Q 2.33= 130.140 m VELOCITY= 2.89 m/s
	Q 10 = 130.270 m = 2.78 m/s
	Q 25 = 130.360 m = 2.89 m/s
	Q 50 = 130.460 m = 3.00 m/s
	Q 100 = 130.560 m = 3.07 m/s

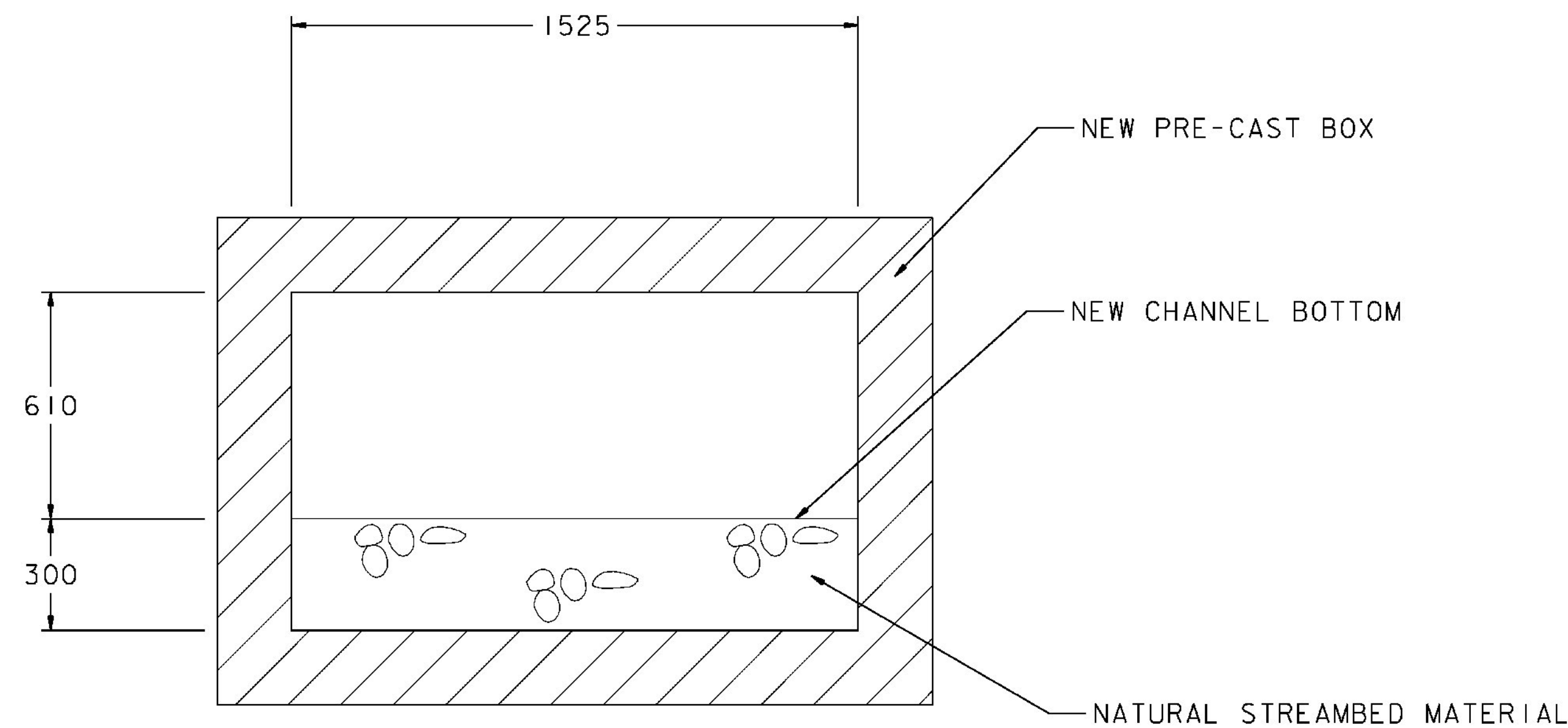

PRE-CAST BOX CULVERT

NOTE

- PHASED CONSTRUCTION WILL BE REQUIRED TO CONSTRUCT PROPOSED STRUCTURE.
- DESIGN AND DETAILING OF PRECAST CONCRETE BOX CULVERT SHALL BE THE CONTRACTOR'S OR MANUFACTURER'S RESPONSIBILITY. DESIGN SHALL BE BASED ON AASHTO AND VTRANS STANDARDS USING LOAD FACTOR DESIGN METHOD AND MS22.5 LOADING. SHOP DRAWINGS SHALL BE SUBMITTED FOR DOCUMENTATION SHOWING REINFORCING BAR SIZES AND LOCATIONS AND JOINT DETAILS AND SHALL INCLUDE DESIGN CALCULATIONS. DRAWINGS AND CALCULATIONS SHALL BE PREPARED AND STAMPED BY A PROFESSIONAL ENGINEER LICENSED BY THE STATE OF VERMONT. ALL COSTS FOR DESIGN, DRAWINGS, FABRICATION, DELIVERY, AND ERECTION SHALL BE INCLUDED IN THE COST OF THE PRECAST CONCRETE STRUCTURE.

DESIGN CRITERIA:

- DESIGN LIVE LOAD AASHTO MS 22.5
- DESIGN SPAN 1.525 m
- ALLOWABLE LOAD FOR SPREAD FOOTINGS ON SOIL ON LEDGE
- ALLOWABLE LOAD FOR PILING N/A TYPE ESTIMATED LENGTH
- STRUCTURAL STEEL AASHTO GRADE N/A
- REINFORCING STEEL GRADE 420
- HIGH PERFORMANCE CONCRETE CLASS A f_c 30 MPa
HIGH PERFORMANCE CONCRETE CLASS B f_c 25 MPa

TRAFFIC MAINTENANCE:

- IS TRAFFIC TO BE MAINTAINED? YES IF YES, 'ON EXISTING STRUCTURE YES OR ON TEMPORARY BRIDGE NO
- TEMPORARY BRIDGE REQUIREMENTS: ONE OR TWO WAY N/A
TRAFFIC CONTROL SIGNALS REQUIRED NO
ARE SIDEWALKS REQUIRED? NO IF SO, ON WHAT SIDE?
STRUCTURE TYPE: N/A

NOTE

PHASED CONSTRUCTION WILL BE REQUIRED TO CONSTRUCT PROPOSED BOX CULVERT

LOAD RATING (TONS) (LOAD FACTOR)	
RATING	
INVENTORY	
POSTED	
OPERATING	

STATE OF VERMONT AGENCY OF TRANSPORTATION

Town Of BRANDON Bridge No. -
Highway No. US ROUTE 7 Log Sta. -
Surv. Sta. 18+127,000

US ROUTE 7 (PRINCIPAL ARTERIAL)

PRELIMINARY INFORMATION (1 OF 1)

Designed By CLD Date 08/09 Drawn By PTS
Checked By CLD Date 08/09 Bridge Design Supervisor CRB Date 08/09

PROJECT BRANDON PROJECT NO. NH 019-3(495)

I.G.C. Info. Bridge Sheet No. Sheet 138 of 546

