

PIPES  
LENGTH TO BE RESTRAINED FROM EACH SIDE OF FITTING (m)

NOMINAL PIPE SIZE (mm)	HORIZONTAL BEND ANGLE (DEG)					TEE (SAME D.I.A.)		DEAD END
	90	45	22.5	11.25	VALVE	MAIN	BRANCH	
200	8.2	3.7	1.8	0.9	8.2	3.0	7.6	14.6
300	11.6	4.9	2.4	1.2	11.6	3.0	13.7	21.0
400	14.9	6.4	3.0	1.5	14.9	3.0	15.2	27.1

REDUCERS  
RESTRAIN ON LARGE DIA. SIDE OF REDUCER

NOMINAL PIPE SIZES (mm)	LENGTH TO BE RESTRAINED (m)
200 x 100	10.7
300 x 200	11.3
300 x 150	15.2
400 x 300	11.6
400 x 200	19.8

VERTICAL OFFSET - EQUAL ANGLE  
RESTRAIN ON 45 DEGREE BEND

NOMINAL PIPE SIZE (mm)	LENGTH TO BE RESTRAINED (m)	
	FROM UPPER BEND	FROM LOWER BEND
200	6.1	1.8
300	8.8	3.4
400	11.3	4.3

NOTE: LOWER BEND ASSUMED TO HAVE 2.4 m COVER

DESIGN CONDITIONS  
PIPE MATERIAL: DUCTILE IRON (DI), CLASS 52, CLASS 56 FOR RIVER CROSSING  
SOIL TYPE: SILTY SAND  
DEPTH OF COVER: 1.75 m (DEPTH WILL VARY TO AVOID OTHER UNDERGROUND FEATURES).  
SEE PROFILES AND ROADWAY CROSS SECTIONS. INSULATION NEEDED IF COVER LESS THAN 1.75 m  
DESIGN PRESSURE: 1720 kPa (250 PSI)  
SAFETY FACTOR: 1.5

- NOTES
- THE ABOVE TABLES ARE NOT INCLUSIVE OF ALL CONDITIONS OR GEOMETRIES THAT MAY BE ENCOUNTERED IN THE FIELD. THE CONTRACTOR SHALL CONSULT THE MANUFACTURER OF THE MEGALUG PRODUCT FOR GUIDANCE PRIOR TO INSTALLATION.
  - 90 DEGREE VERTICAL EQUAL ANGLE OFFSETS ARE NOT ALLOWED.
  - RESTRAINED MECHANICAL JOINTS SHALL BE USED AT ALL PIPE BENDS, FITTINGS, VALVES, AND APPURTENANCES. FLEXIBILITY OF THE JOINT SHALL BE MAINTAINED AFTER BURIAL. GLAND BODY SHALL BE MANUFACTURED OF HIGH STRENGTH DUCTILE IRON GRADE 65-45-12 IN ACCORDANCE WITH ASTM A536. RESTRAINING DEVICES SHALL BE OF DUCTILE IRON HEAT TREATED TO A MINIMUM HARDNESS OF 370 BHN.
  - BOLTS AND TWIST-OFF NUTS SHALL BE USED TO INSURE PROPER ACTUATING OF THE RESTRAINING DEVICES AS MANUFACTURED BY NSS OR BIRMINGHAM FASTENER. DIMENSIONS OF THE GLAND SHALL BE SUCH THAT IT CAN BE USED WITH THE STANDARDIZED MECHANICAL JOINT BELL AND TEE-HEAD BOLTS CONFORMING TO ANSI A21.11 (AWWA C111) AND ANSI A21.53 (AWWA C153).
  - ONLY MEGALUG PRODUCTS AS MANUFACTURED BY EBAA IRON, INC. SHALL BE USED ON THIS PROJECT. CAST BODIES SHALL RECEIVE MEGA-BOND COATING AS PROVIDED BY EBAA IRON, INC. SEE THE THRUST RESTRAINT DESIGN TABLE SHOWN ON THE PLANS.
  - RESTRAINT OF PUSH-ON-JOINTS SHALL BE THROUGH THE USE OF FIELD LOK 350 GASKETS AS MANUFACTURED BY US PIPE, OR EQUAL. FIELD LOK 350 GASKETS WILL NOT BE ALLOWED FOR USE ON FITTINGS, VALVES OR APPURTENANCES.

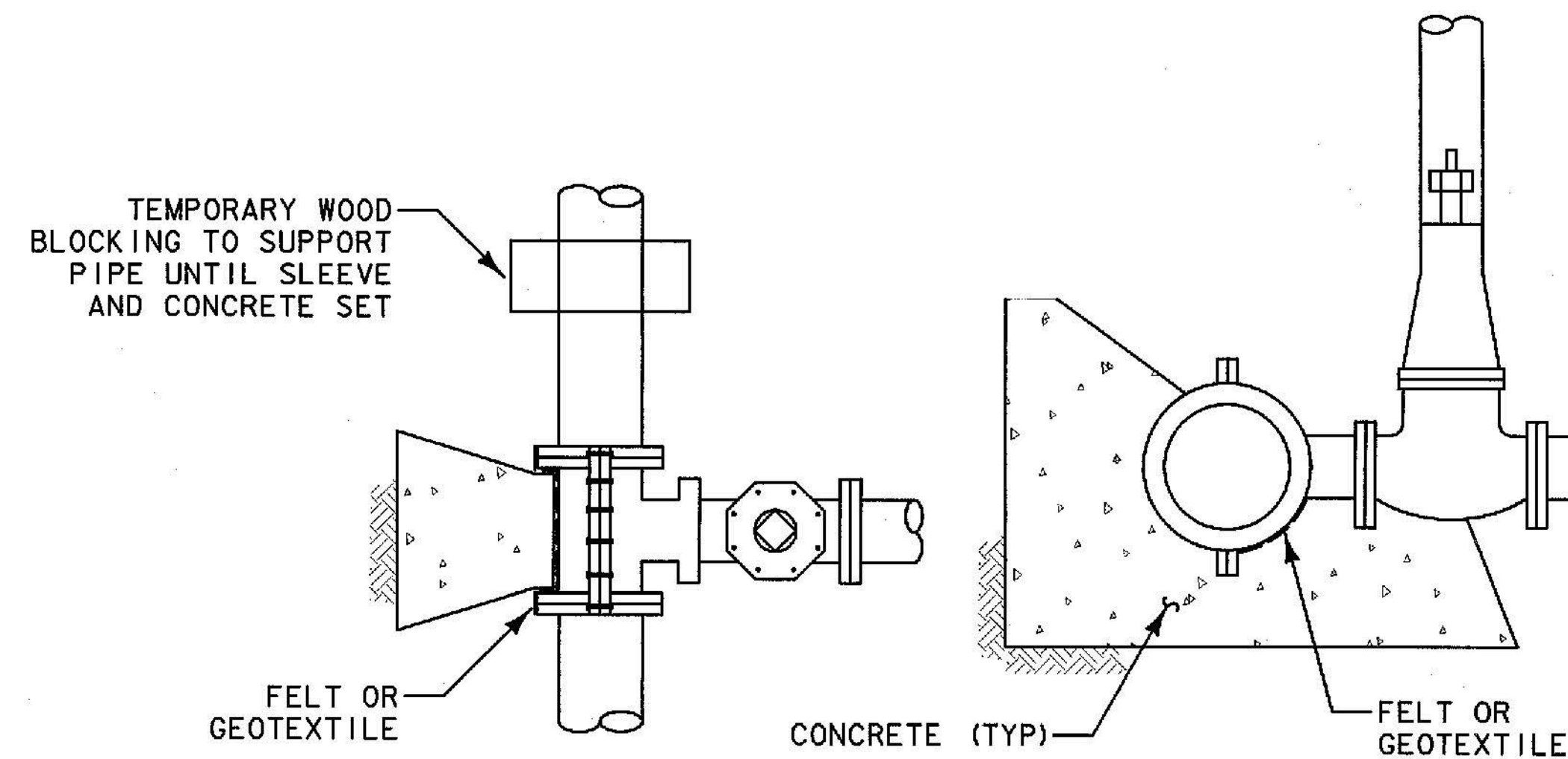

**WATER TAPPING SLEEVE**

**THRUST RESTRAINT DESIGN (WATER MAIN)**

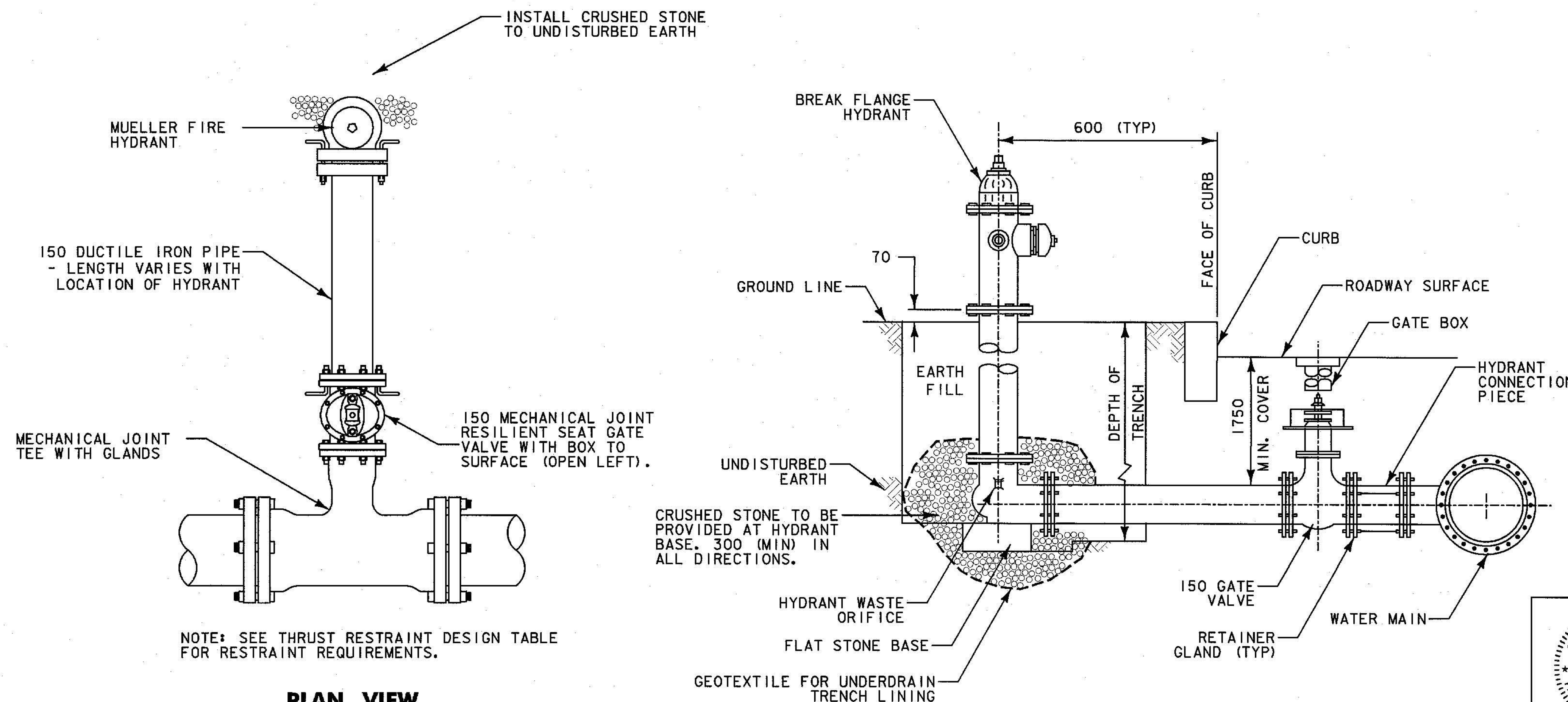

HYDRANT NOTES:

- ALL MATERIALS AND INSTALLATION PROCEDURES SHALL CONFORM TO AWWA TECHNICAL SPECIFICATIONS.
- ALL HYDRANTS SHALL BE MUELLER SUPER CENTURION AS REQUIRED OF BRANDON FIRE DISTRICT #1. PROVIDE STAINLESS STEEL BOLTS AND NUTS.
- SUBSTITUTE MEGALUGS IN LIEU OF THREADED ROD OR GRIP RINGS.
- THE HYDRANT DRAIN PORT SHALL BE PLUGGED IN AREAS OF HIGH GROUNDWATER OR WITHIN 3.0 m (10 FT.) OF A SANITARY SEWER.

NOTE: SEE THRUST RESTRAINT DESIGN TABLE FOR RESTRAINT REQUIREMENTS.

PLAN VIEW

**TYPICAL HYDRANT INSTALLATION**

NOT TO SCALE

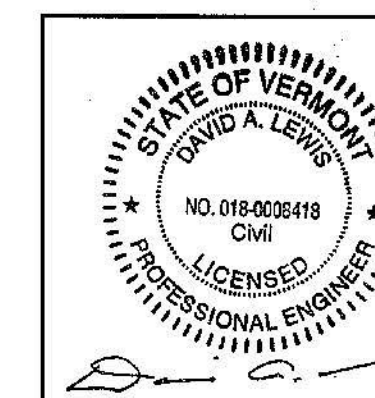

3	AUG. 2009	MODIFIED TO ADDRESS CONTRACT ADMINISTRATIONS COMMENTS
2	MAR. 2009	BRANDON SEGMENT 5 PLAN REVISIONS
1	JAN. 2006	MODIFIED TO ADDRESS APRIL 18, 2005 WATER SUPPLY DIVISION COMMENTS

**WATER DETAILS 1**

PROJECT NAME: BRANDON  
PROJECT NUMBER: NH 019-3(496)

FILE NAME: zb008s6-swrdef.dgn

PLOT DATE: 1/9/2006

PROJECT LEADER: HJM

DRAWN BY: KLS

DESIGNED BY: DAL

CHECKED BY: DAL

SHEET 141 OF 546

DEC SHEET 162 OF 437