

G20-4

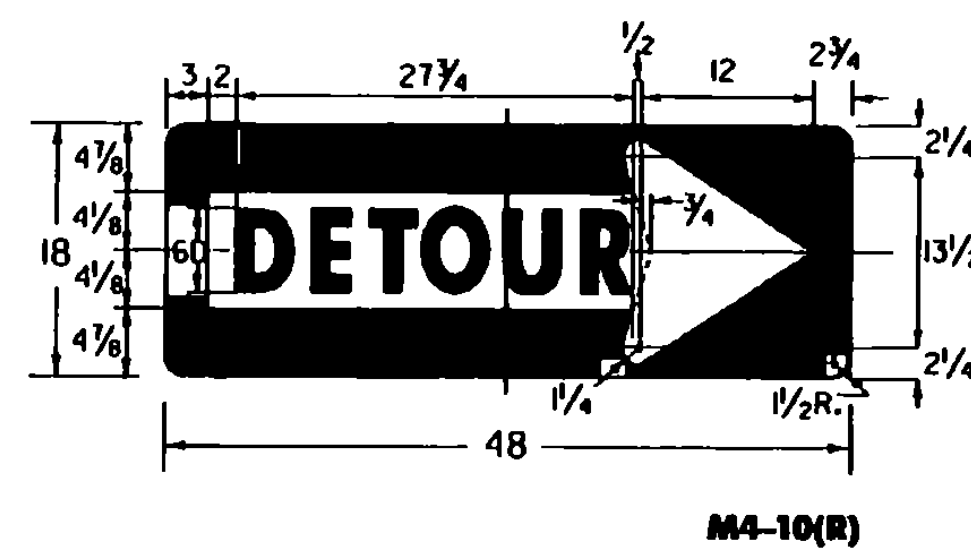

M4-10(R)

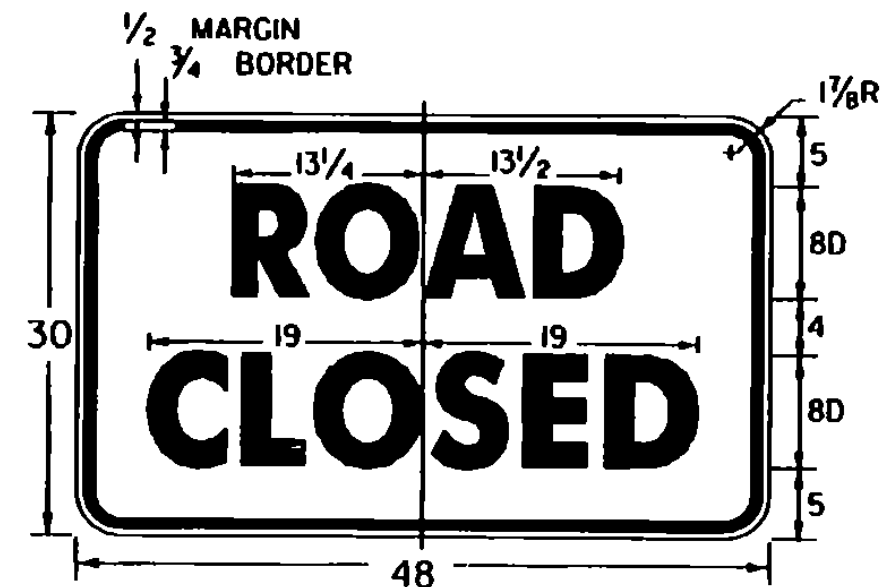

COLORS:
BLACK TEXT AND BORDER
WHITE REFLECTORIZED BACKGROUND

R11-2

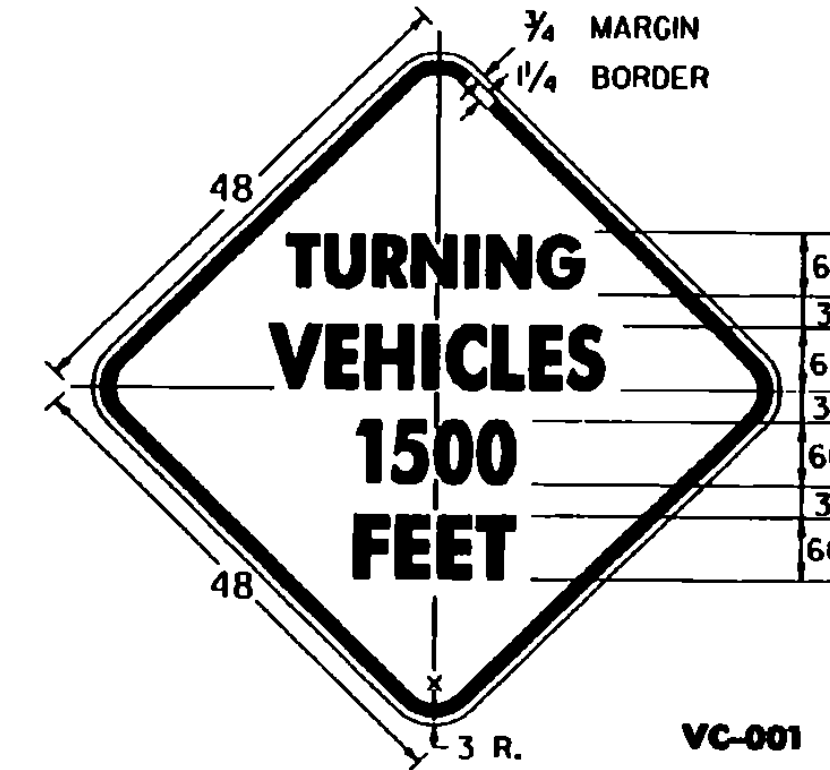

VC-001

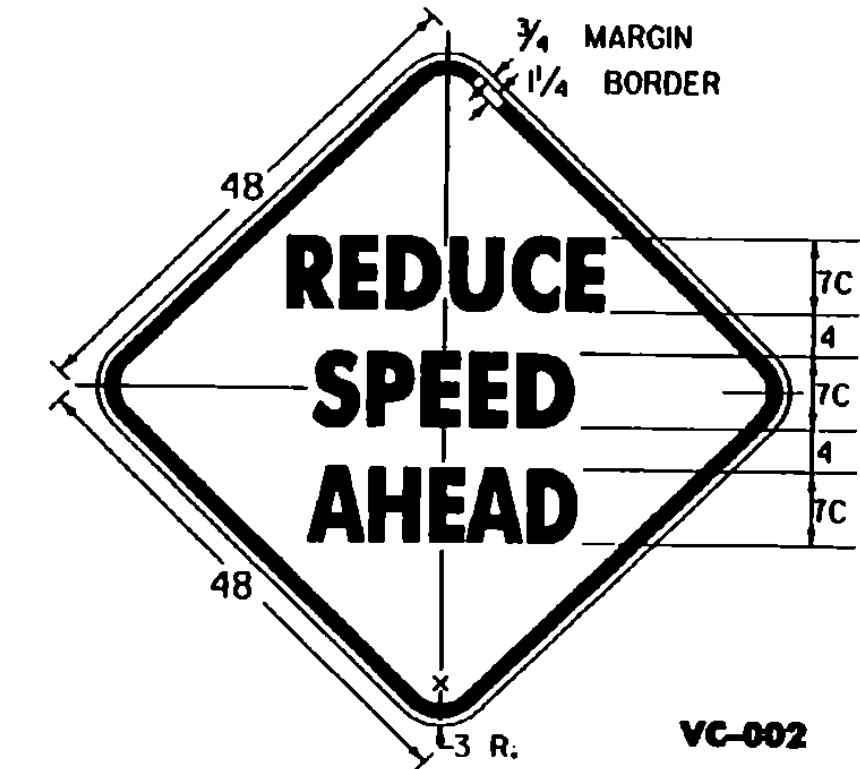

VC-002

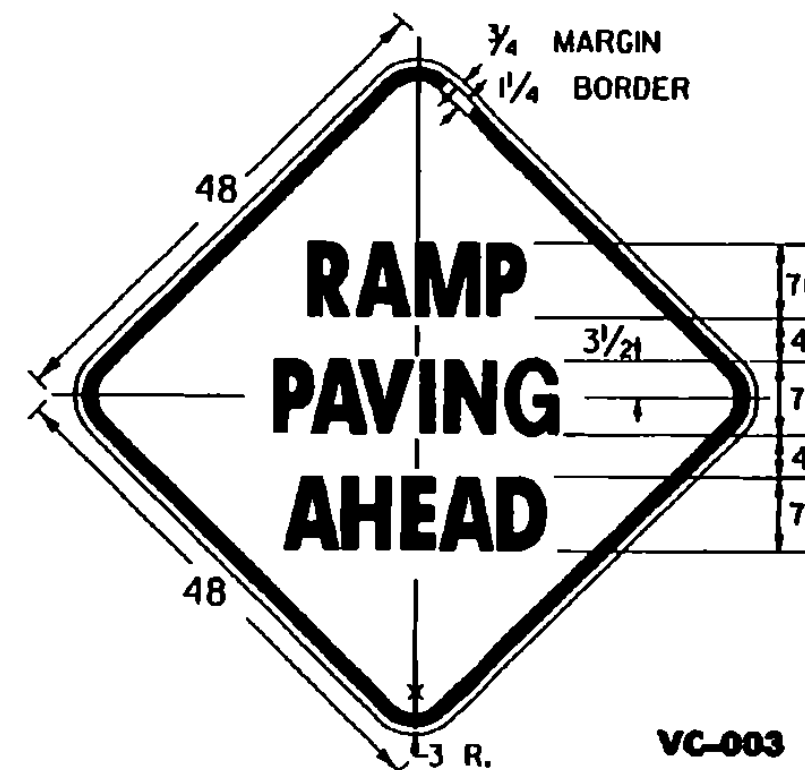

VC-003

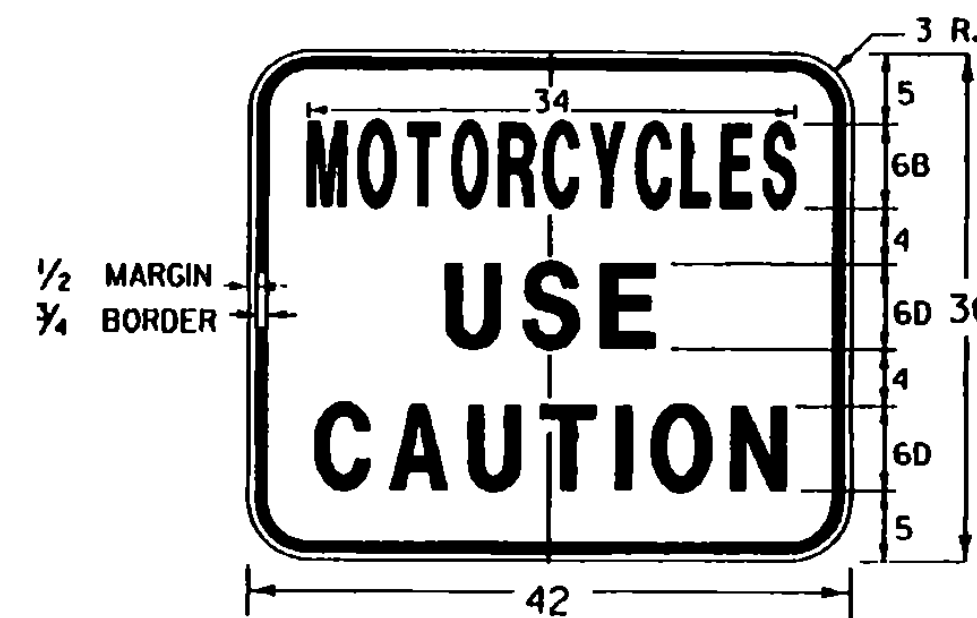

VC-004

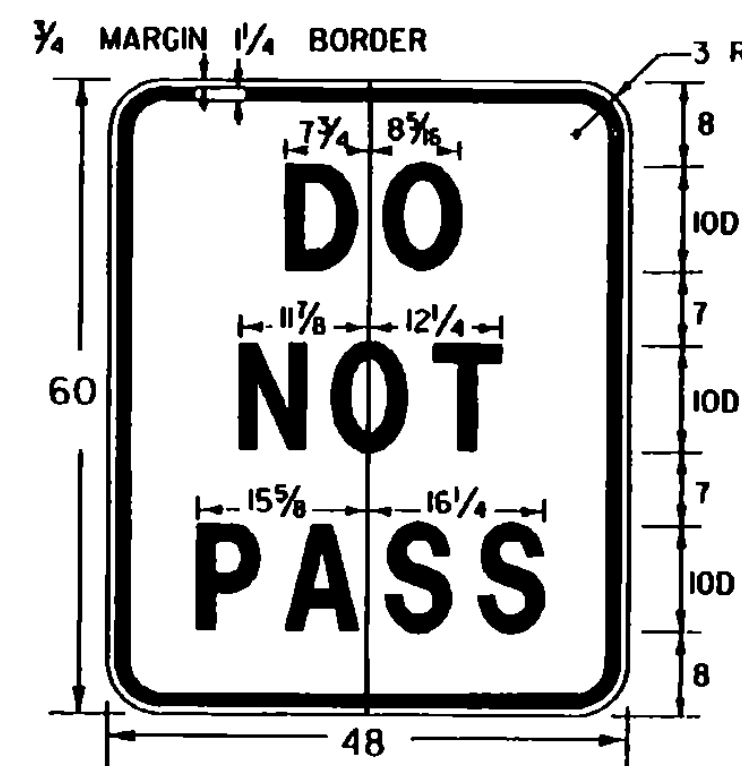

VC-005

* REDUCE SPACING BY 40%

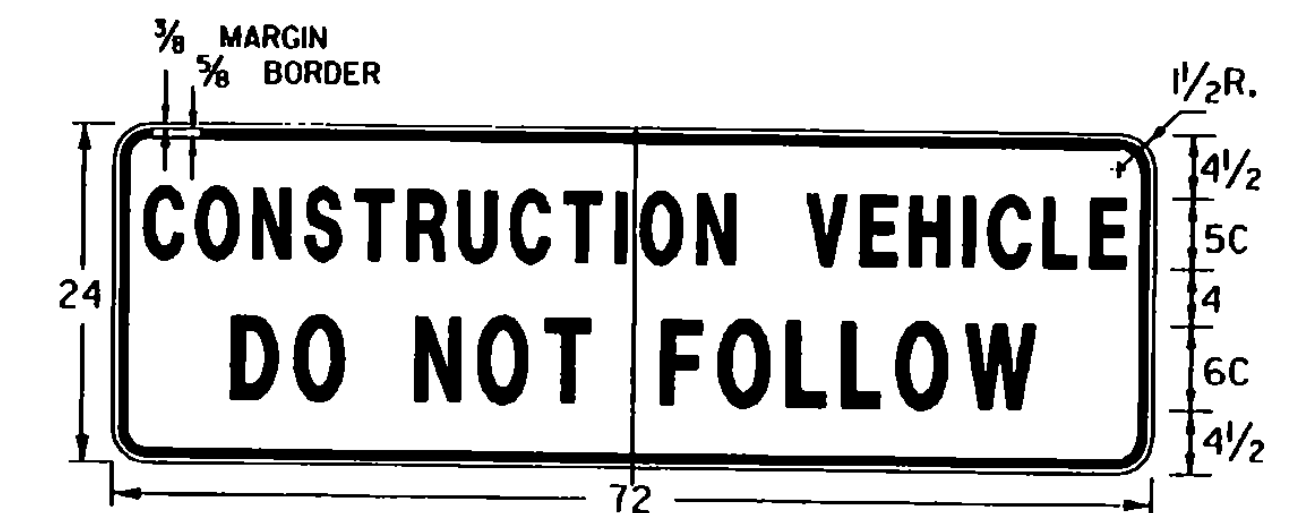

VC-007

IT IS SUGGESTED THAT THIS SIGN BE DESIGNED TO FOLD, (DOWN OR ACROSS), OR BE COVERED, OR BE REMOVED WHEN NOT IN USE. THE SIGN SHOULD ALSO BE MOUNTED AS TO NOT INTERFERE WITH THE VISIBILITY OF DIRECTIONAL OR TAIL LIGHTS AS REQUIRED BY LAW.

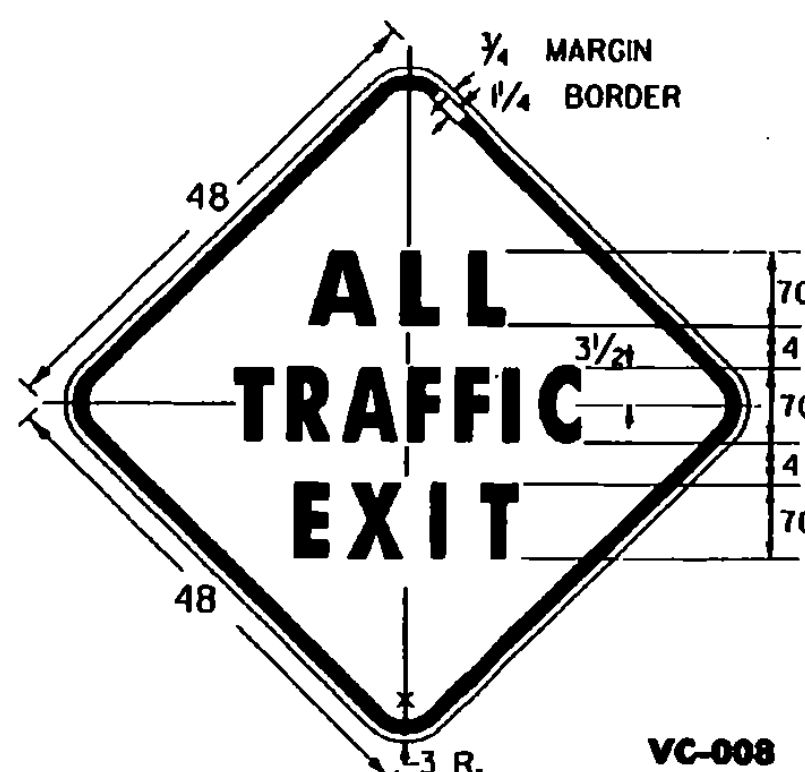

VC-008

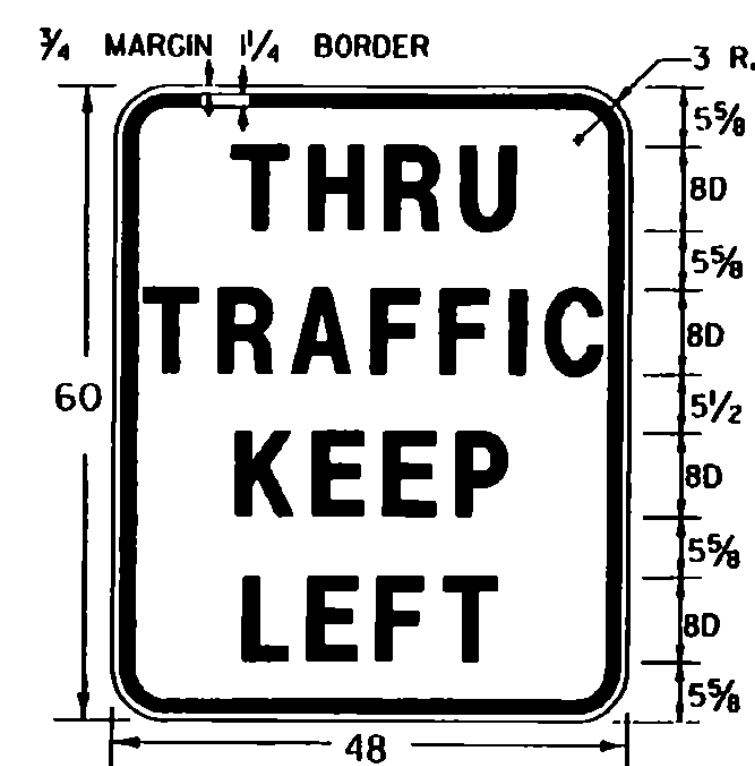

VB-118

COLORS: BLACK BORDER & TEXT
WHITE (REFL.) BACKGROUND

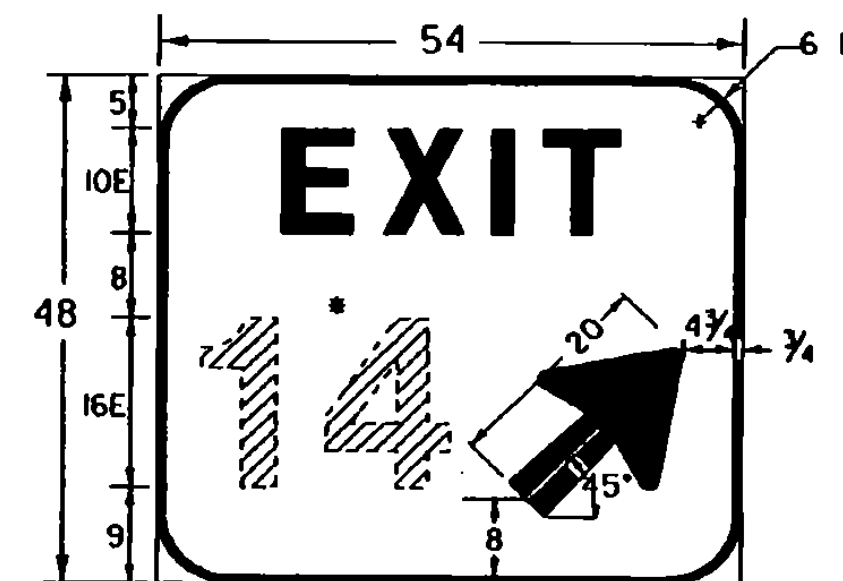

E5-1a

* EXIT NUMBER AS PER PLANS OPTICALLY SPACED
COLORS:
BACKGROUND - GREEN (REFL.)
BORDER, ARROW AND LEGEND - WHITE (REFL.)

(ALL DIMENSIONS SHOWN IN INCHES)

NOTES

SEE STANDARD SHEET E-100 FOR NOTES AND TEXT DETAILS

COLORS FOR SIGNS SHOWN ON THIS SHEET SHALL BE BLACK TEXT, BORDER AND SYMBOLS. SHALL BE ON A REFLECTORIZED ORANGE BACKGROUND OF TYPE II B OR TYPE III REFLECTIVE SHEETING, UNLESS OTHERWISE NOTED.

SIGN DETAILS INDICATE THE APPROPRIATE COLOR.

SIGNS USED ONLY FOR DAYTIME MAINTENANCE OPERATIONS DO NOT NEED TO BE REFLECTORIZED, HOWEVER, THESE SIGNS SHALL BE LABELED "DAYTIME USE ONLY" ON THE BACK OF THE SIGN PANEL WITH 3" SERIES C LETTERS.

OTHER STDS. E-100 REQUIRED:



STANDARD
E-102A

REVISIONS AND CORRECTIONS

AUG 08, 1995 - DATE OF ORIGINAL ISSUE

APPROVED FOR THIS PROJECT AND/OR DESIGN IMPLEMENTATION. FHWA FINAL APPROVAL PENDING.

APPROVED

Stephen D. McArthur
DIRECTOR OF ENGINEERING

David A. Ross
TRAFFIC AND SAFETY ENGINEER

CONSTRUCTION SIGN
DETAILS