

G20-4

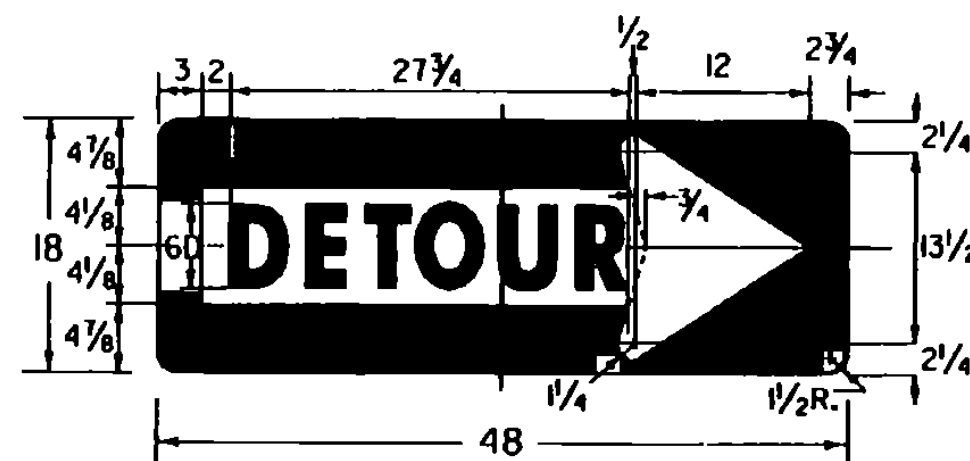

M4-10(R)

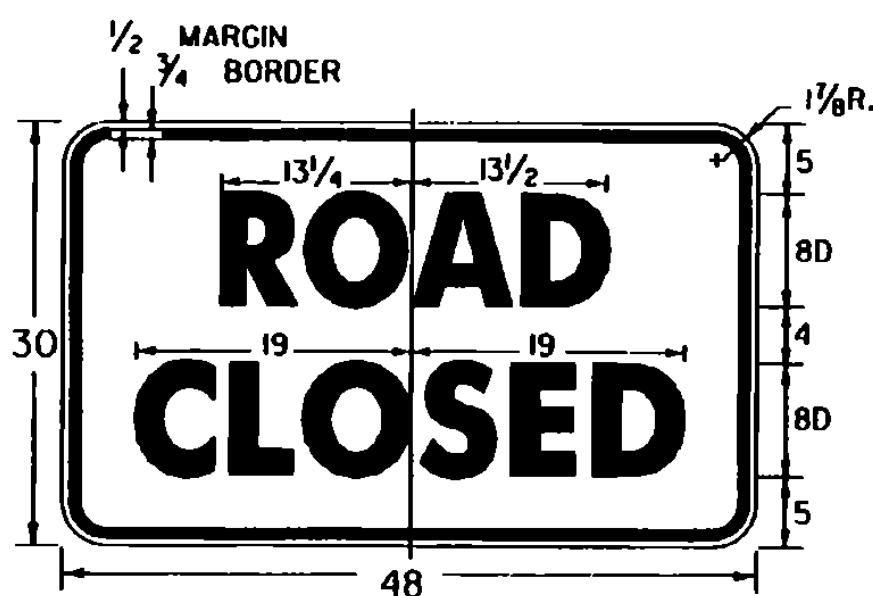

COLORS:
BLACK TEXT AND BORDER
WHITE REFLECTORIZED BACKGROUND

R11-2

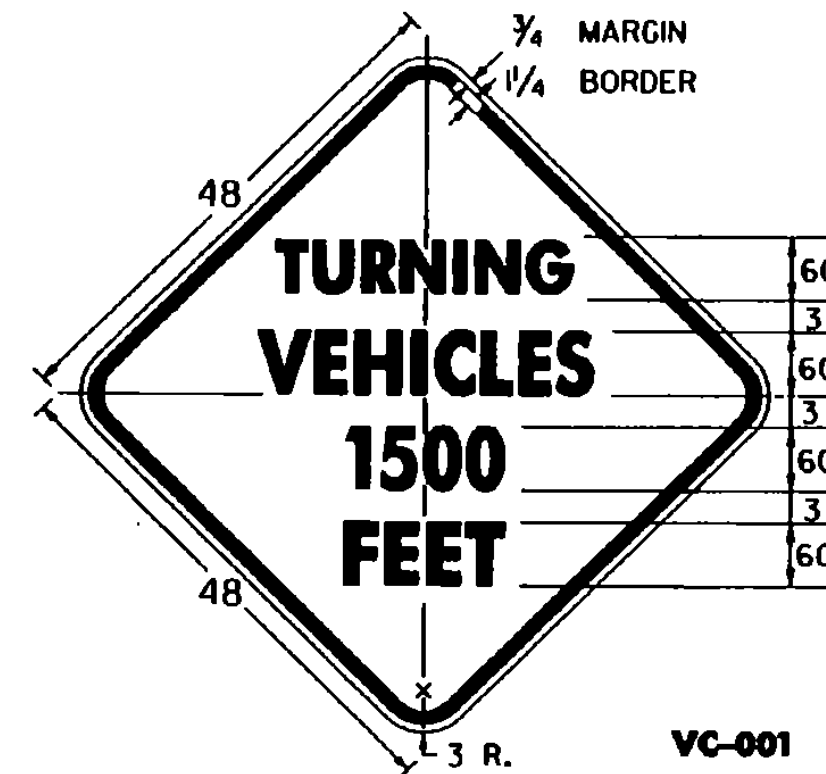

VC-001

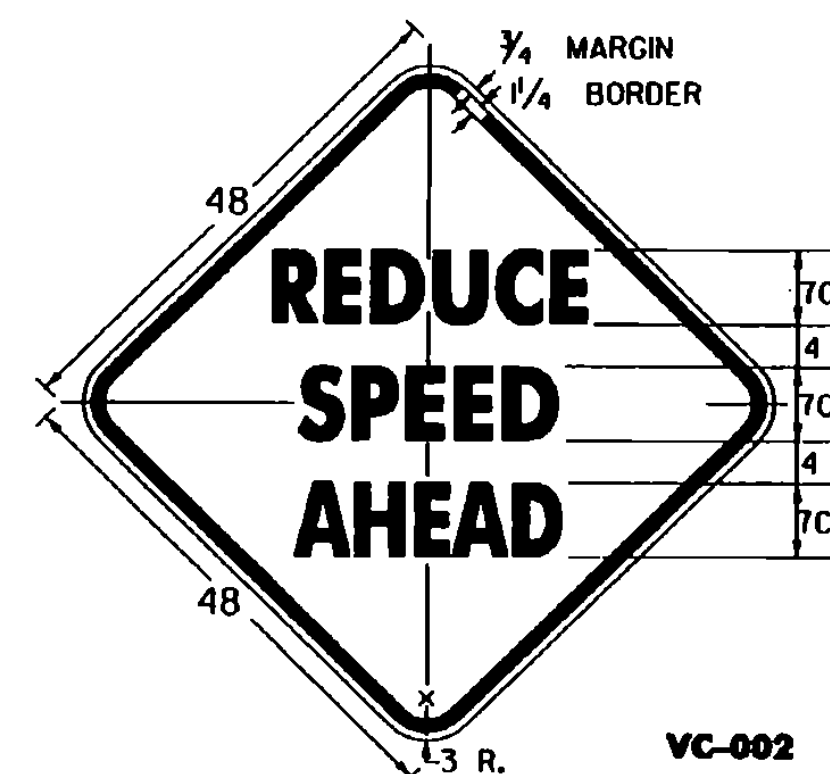

VC-002

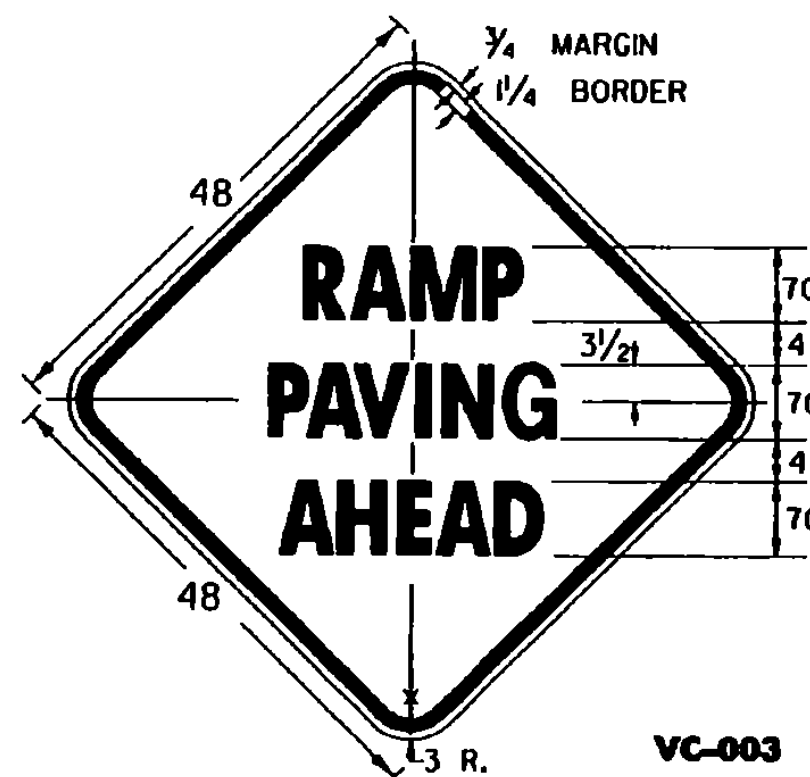

VC-003

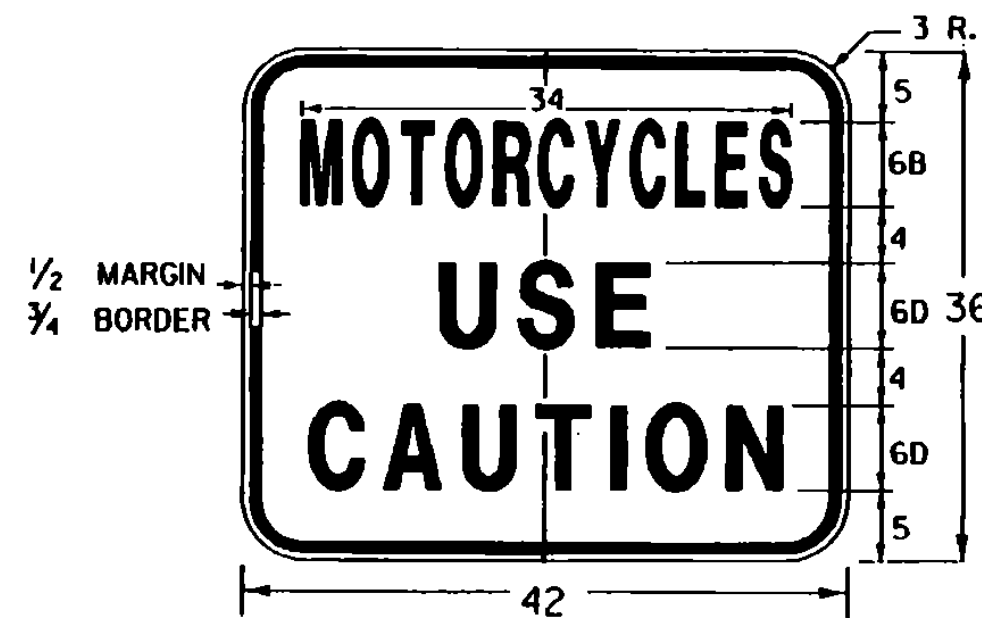

VC-004

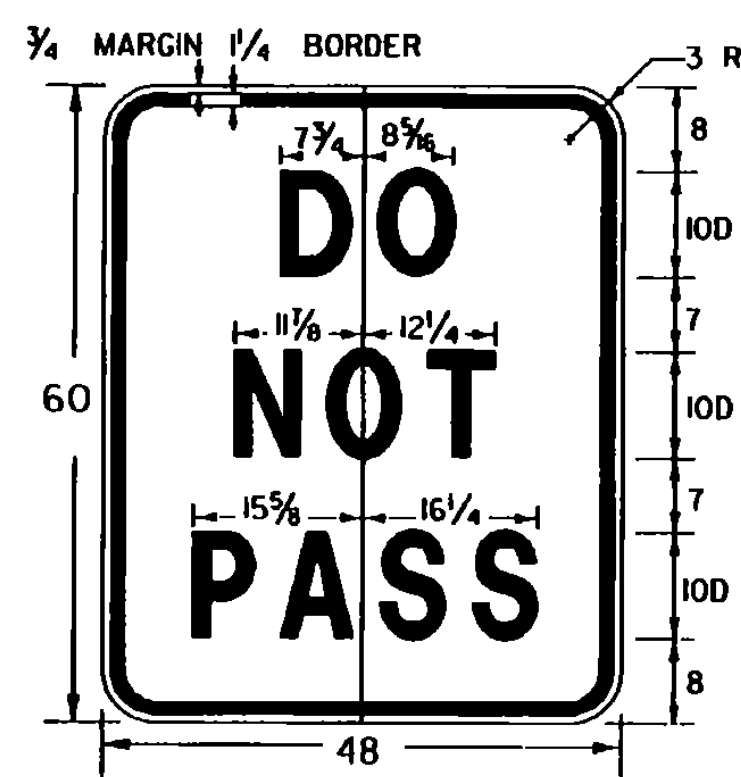

VC-005

* REDUCE SPACING BY 40%

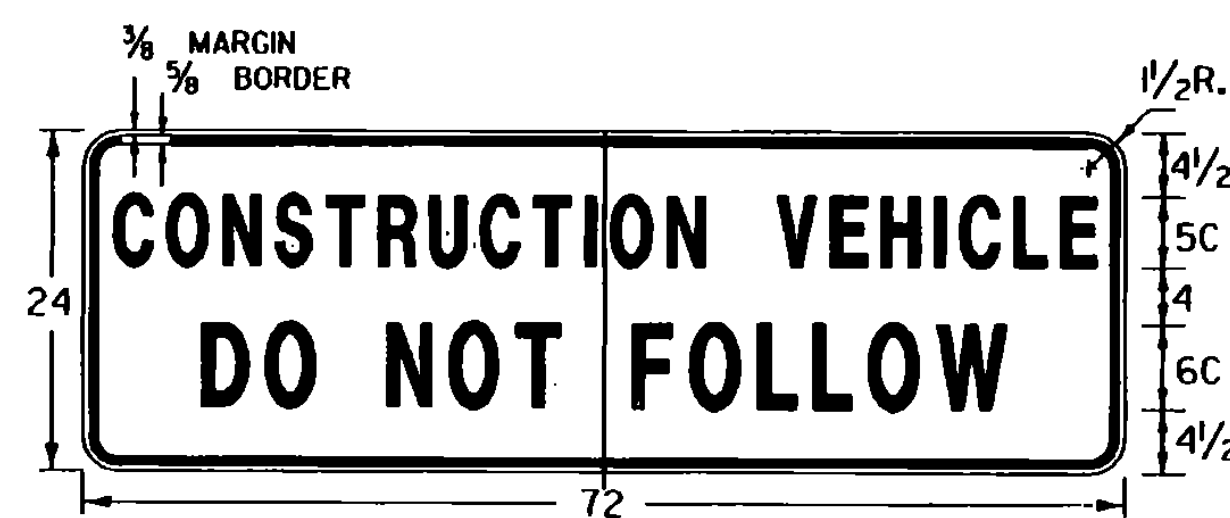

VC-007

IT IS SUGGESTED THAT THIS SIGN BE DESIGNED TO FOLD, (DOWN OR ACROSS), OR BE COVERED, OR BE REMOVED WHEN NOT IN USE. THE SIGN SHOULD ALSO BE MOUNTED AS TO NOT INTERFERE WITH THE VISIBILITY OF DIRECTIONAL OR TAIL LIGHTS AS REQUIRED BY LAW.

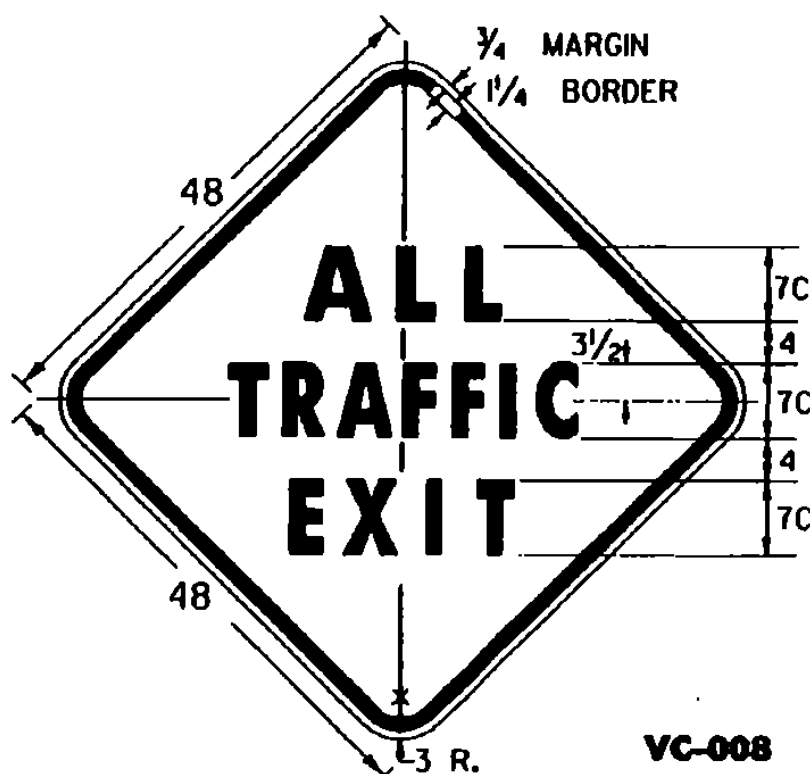

VC-008

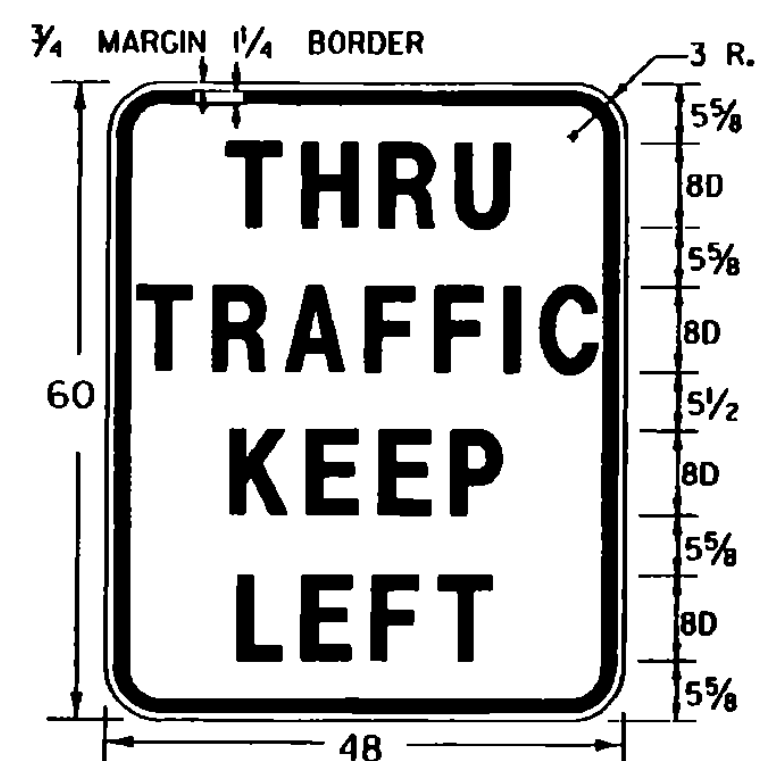

VR-118

COLORS: BLACK BORDER & TEXT
WHITE (REFL.) BACKGROUND

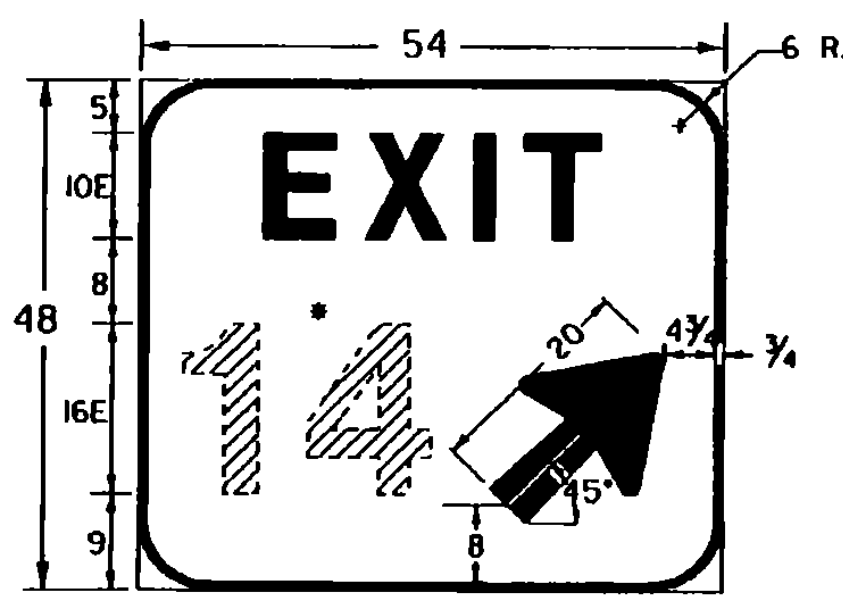

ES-1a

* EXIT NUMBER AS PER PLANS
OPTICALLY SPACED

COLORS:
BACKGROUND - GREEN (REFL.)
BORDER, ARROW AND LEGEND - WHITE (REFL.)

(ALL DIMENSIONS SHOWN IN INCHES)

OTHER STDS. E-100
REQUIRED:

REVISIONS AND CORRECTIONS

AUG 08, 1995 - DATE OF ORIGINAL ISSUE

APPROVED

Stephen D. McCallister
DIRECTOR OF ENGINEERING

David A. Ross
TRAFFIC AND SAFETY ENGINEER

CONSTRUCTION SIGN DETAILS

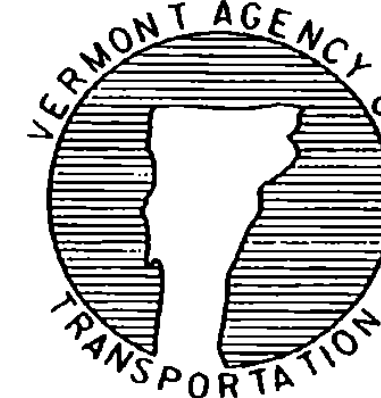

STANDARD E-102A

APPROVED FOR THIS PROJECT
AND/OR DESIGN IMPLEMENTATION
FHWA FINAL APPROVAL PENDING.