

TEMPORARY 4" WHITE LINE, PAINT
 DURABLE 4" WHITE LINE, THERMOPLASTIC
 246+00 TO 251+50 SOLID LT
 246+00 TO 246+31 SOLID RT
 246+31 TO 246+44 SOLID RT (TH 47)
 246+66 TO 246+85 SOLID RT (TH 47)
 246+85 TO 251+50 SOLID RT
 247+50 TO 248+00 DOTTED RT (LANE LINE)
 248+00 TO 248+60 SOLID RT (LANE LINE)

TEMPORARY 24" STOP BAR, PAINT
 DURABLE 24" STOP BAR, THERMOPLASTIC
 246+56 TO 246+69 RT (TH 47)
 TEMPORARY LETTER OR SYMBOL, PAINT
 DURABLE LETTER OR SYMBOL, THERMOPLASTIC
 246+61 RT - STOP (TH 47)
 248+04 RT - LEFT TURN ARROW
 248+54 RT - LEFT TURN ARROW

REHAB. DROP INLETS, CATCH BASINS,
 OR MANHOLES, CLASS I, II, OR III
 246+88 RT (CB)
 246+90 LT (CB)
 248+28 LT (CB)
 249+28 LT (CB)
 CHANGING ELEVATION OF DROP INLETS,
 CATCH BASINS, OR MANHOLES
 (TO BE ADJUSTED BY OWNER)
 246+45 RT (TMH)
 246+48 RT (TMH)

ADJUST ELEVATION
 OF VALVE BOX (NON PART.)
 (TO BE ADJUSTED BY OWNER)
 246+50 LT
 246+56 RT (TH 47)
 246+61 RT (TH 47)
 246+51 RT
 CHANGING ELEVATION
 OF SEWER MANHOLES (NON PART.)
 (TO BE ADJUSTED BY OWNER)
 246+70 RT (TH 47)

REMOVING SIGNS
 AS SHOWN - 31

ERECTING SALVAGED SIGNS
 AS SHOWN - 4

TEMPORARY 4" YELLOW LINE, PAINT
 DURABLE 4" YELLOW LINE, THERMOPLASTIC
 246+00 TO 246+37 SOLID LT TO RT
 246+00 TO 246+37 SOLID RT
 246+56 DOUBLE SOLID RT (TH 47)
 246+72 TO 248+23 SOLID LT
 246+84 TO 248+23 SOLID RT
 248+23 TO 248+60 DOUBLE SOLID LT & RT
 249+00 TO 251+40 DOUBLE SOLID LT & RT
 251+40 TO 251+50 SOLID LT & RT

DURABLE 8" YELLOW LINE, THERMOPLASTIC
 246+00 TO 246+37 SOLID LT & RT (GORE)
 246+72 TO 247+92 SOLID RT (GORE)
 248+23 TO 248+60 SOLID LT & RT (GORE)
 249+00 TO 250+61 SOLID LT & RT (GORE)
 247+60 LT

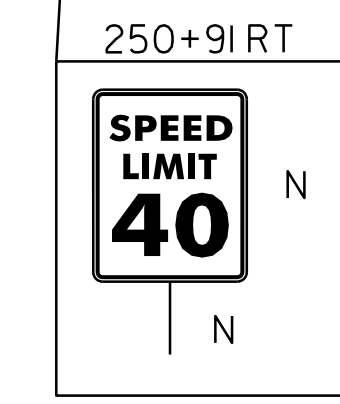
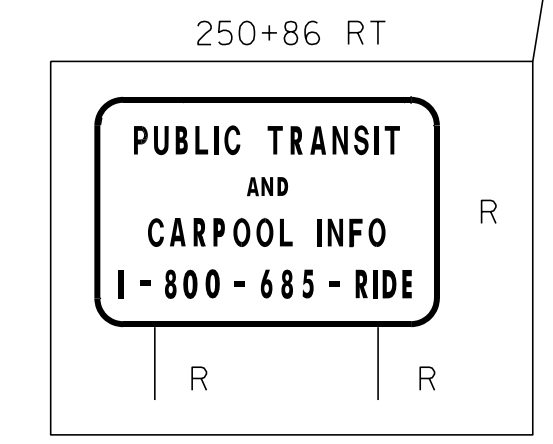
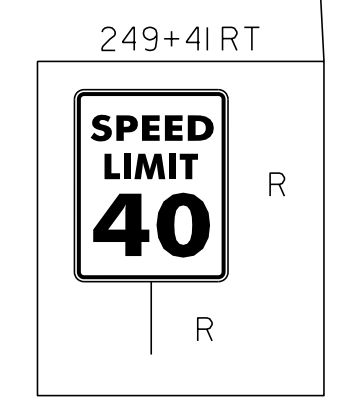
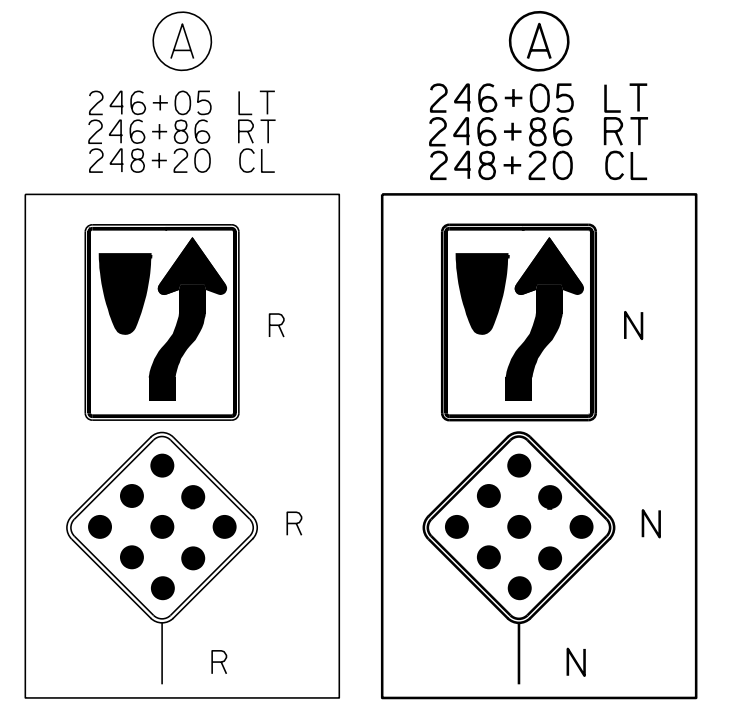
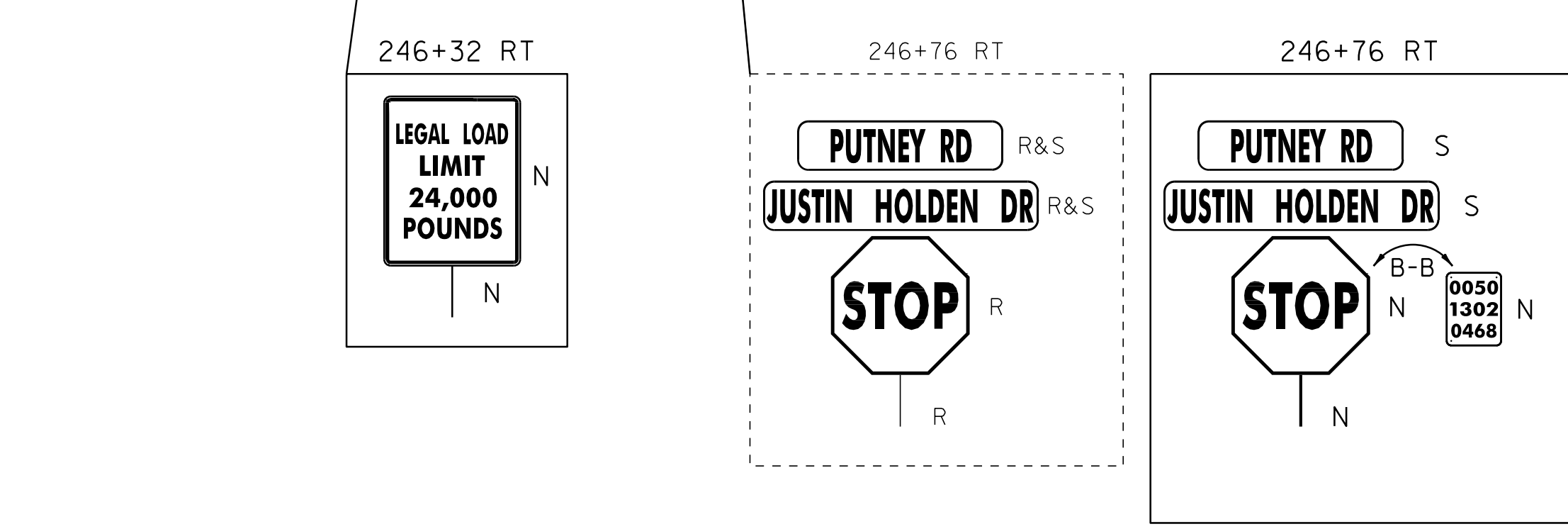
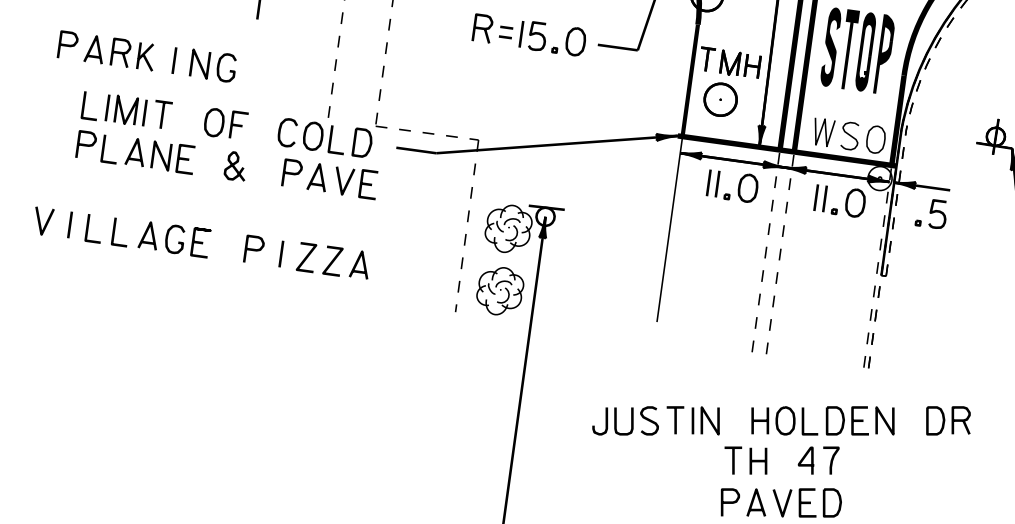
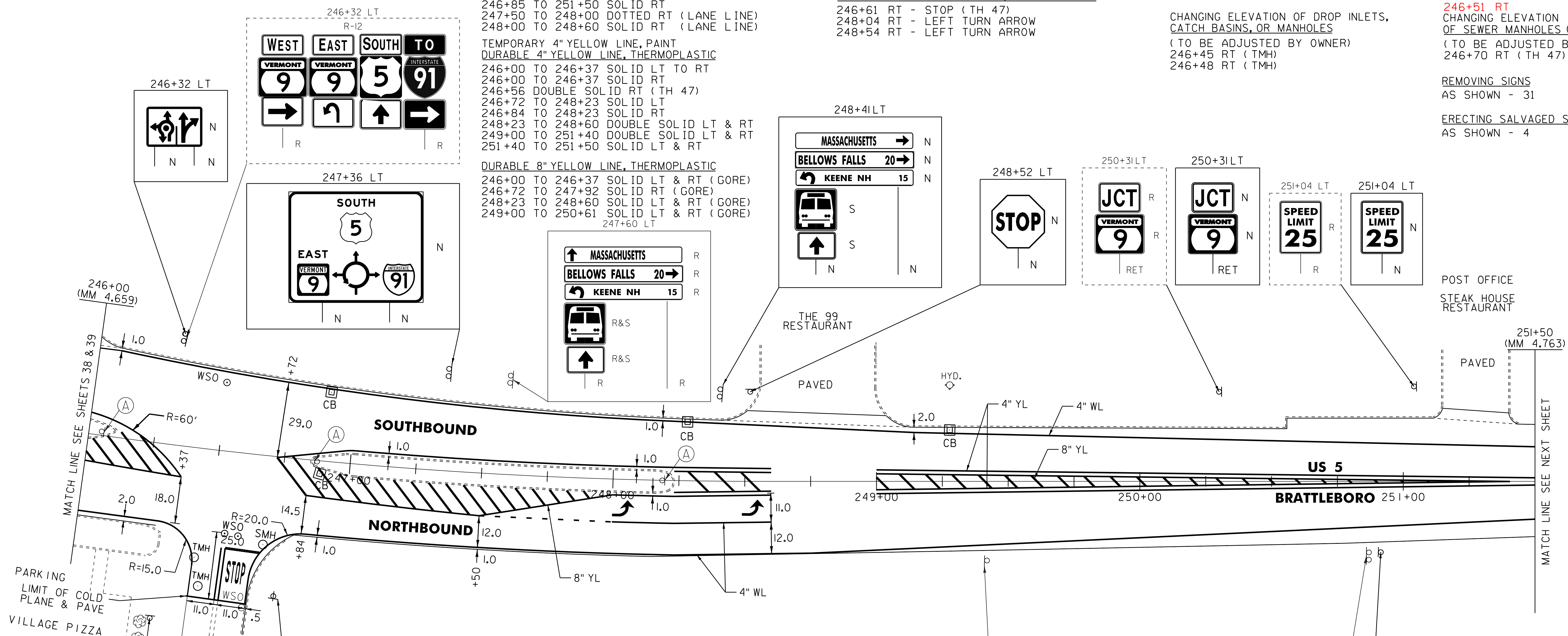

LEGEND

- R = REMOVE EXISTING
- S = SALVAGE
- R&S = REMOVE AND SALVAGE
- N = NEW
- RET = RETAIN
- B-B = BACK TO BACK
- = EXISTING GUARDRAIL
- = PROPOSED GUARDRAIL
- YL = YELLOW LINE
- WL = WHITE LINE
- ⊙ = DELINEATOR

ROADWAY LAYOUT 18 US 5

PROJECT NAME: BRATTLEBORO-PUTNEY	FILE NAME: /pave/01c032/pc032	PLOT DATE: 02-MAY-2012 17:2
PROJECT NUMBER: STP 2310(I)	PROJECT LEADER: PTS	DRAWN BY: WWG
	DESIGNED BY: NLL	CHECKED BY: NLL/PTS
	IPARM FILE NAME: 01C032.42	SHEET 42 OF 118

NOT TO SCALE