

YIELD LINE DETAILS

TO BE INSTALLED ONLY AT THE DIRECTION OF THE RESIDENT ENGINEER TO BE PAID AS ONE LETTER OR SYMBOL PER TRIANGLE

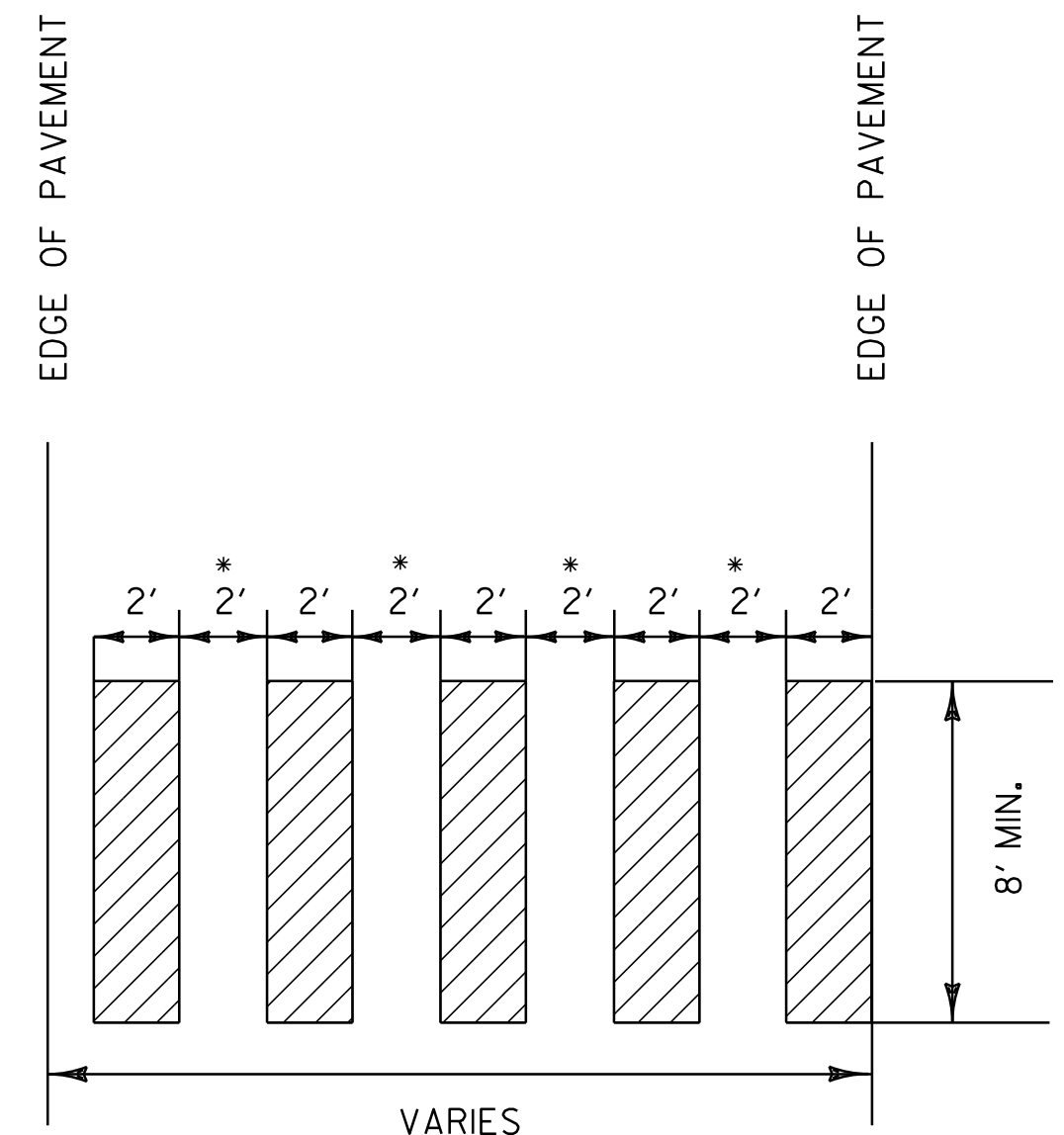
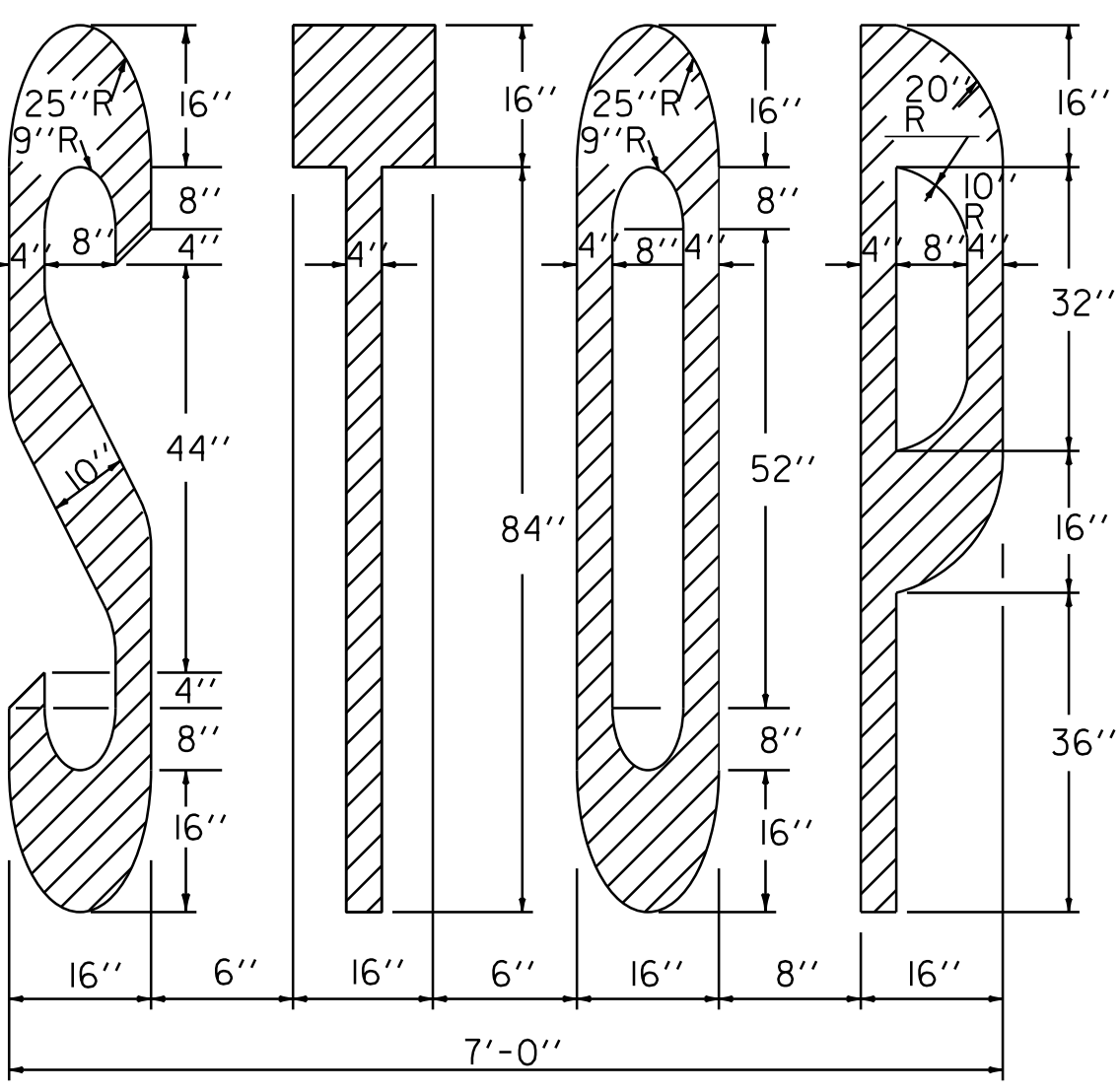
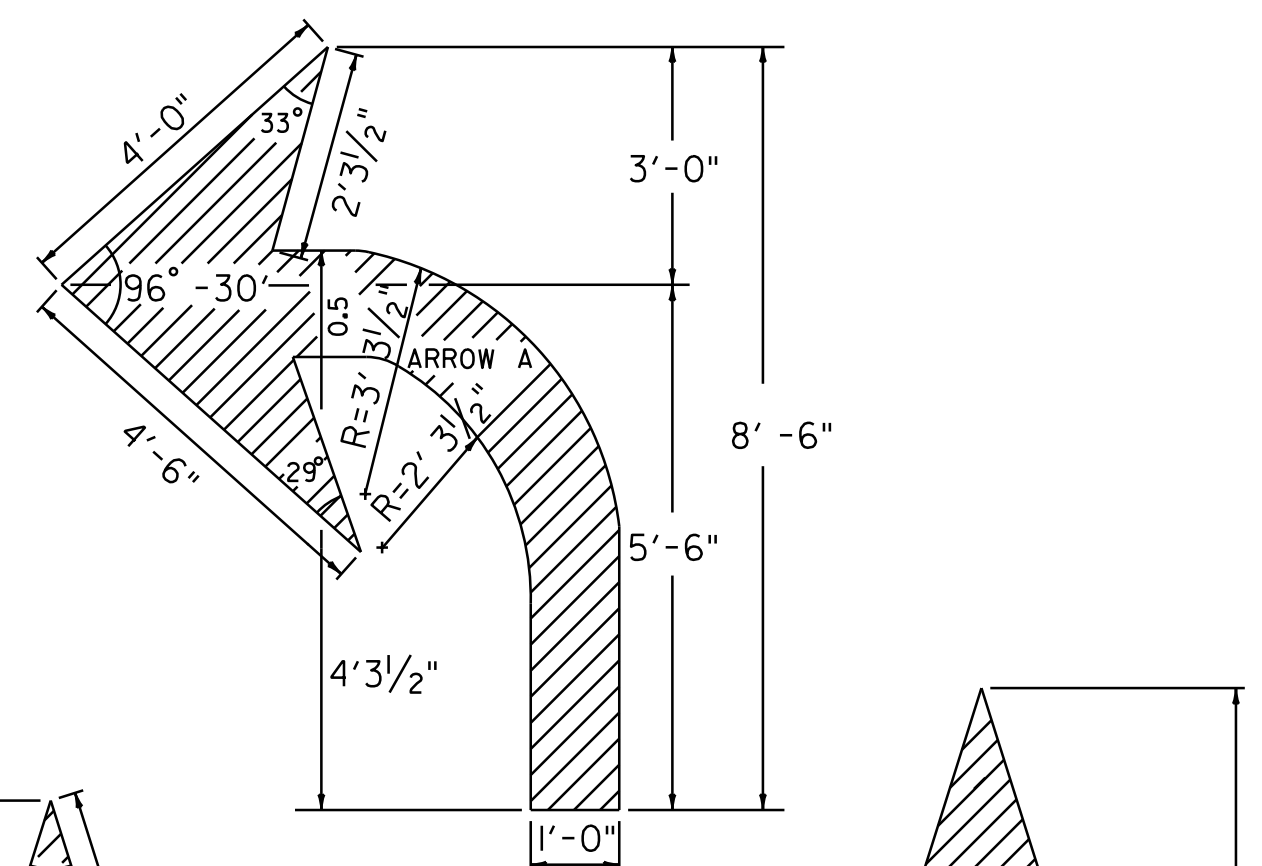
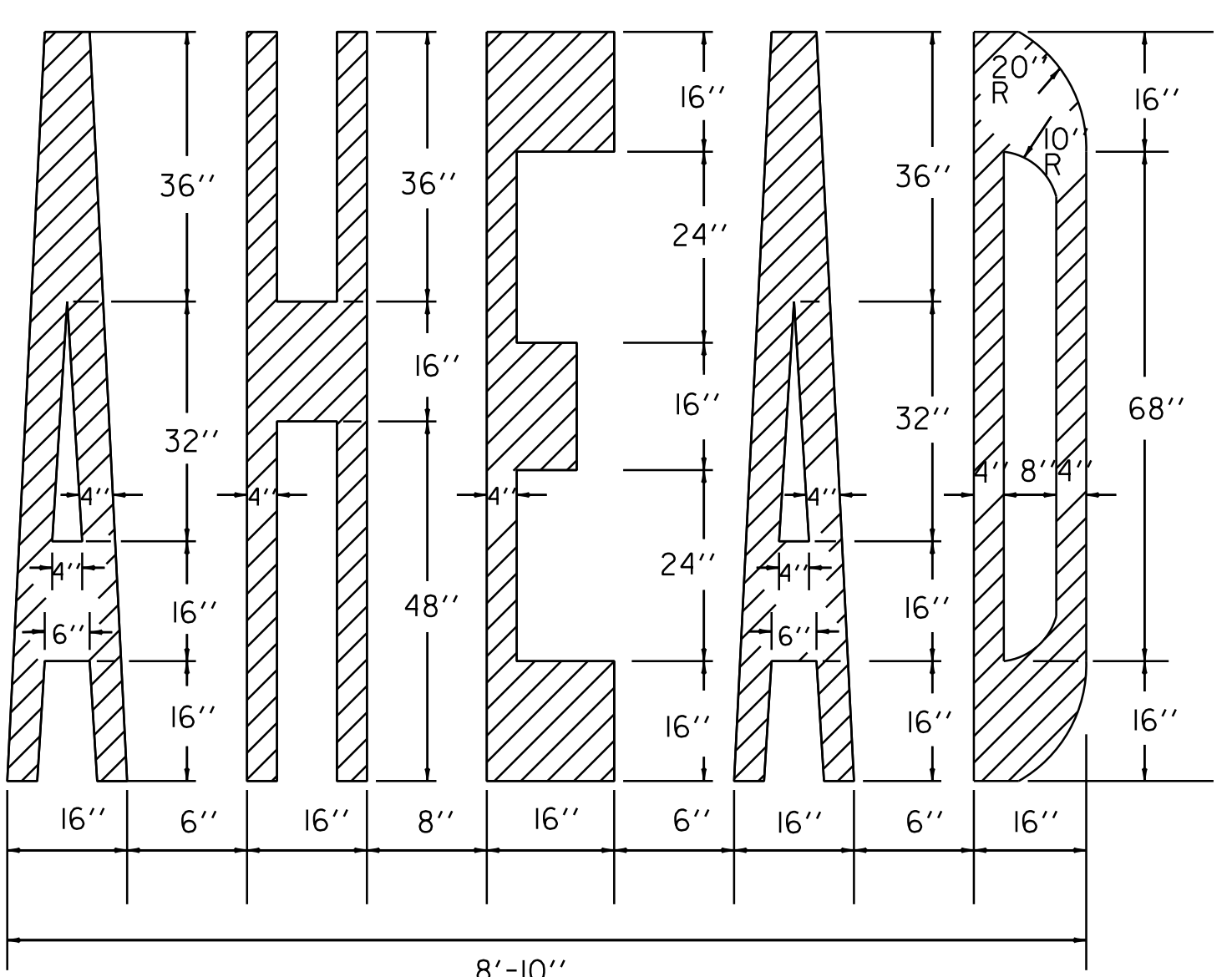
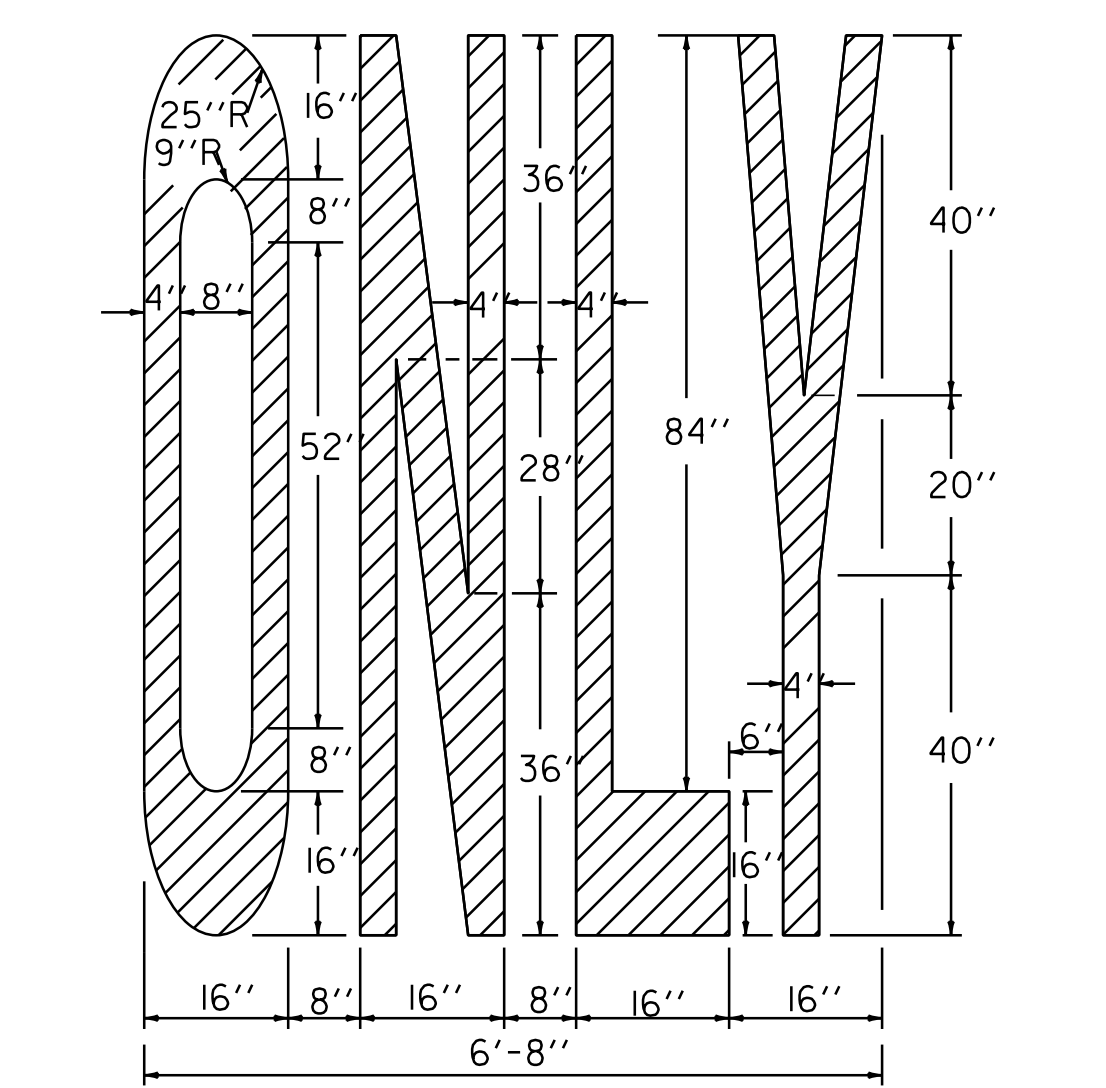

BLOCK PATTERN CROSSWALK DETAIL

ARROW DETAILS

PAVEMENT MARKING DETAILS

TYPICAL MARKINGS FOR TURN LANES

PAVEMENT MARKING DETAIL SHEET

PROJECT NAME: BRATTLEBORO-PUTNEY	FILE NAME: /pave/01c032/pc032	PLOT DATE: 02-MAY-2012 17:2
PROJECT NUMBER: STP 2310(I)	PROJECT LEADER: PTS	DRAWN BY: WWG
	DESIGNED BY: NLL	CHECKED BY: NLL/PTS
	IPARM FILE NAME: 01C032_09	SHEET 9 OF 118